



STROJIRNY
POLDI



NOŽE NA OBRÁBĚNÍ KOVŮ Z RYCHLOŘEZNÝCH OCELÍ



POLOTOVARY NOŽŮ	4
DRŽÁKY NOŽŮ	12
SOUSTRUŽNICKÉ NOŽE	14
REVOLVEROVÉ NOŽE	22
OBRÁŽECÍ NOŽE A DRŽÁKY	30
HOBLOVACÍ NOŽE	34
NOŽE PRO SOUŘADNICOVÉ VYVRTÁVAČKY	38

Informace uvedené v tomto katalogu vycházejí ze současného provedení výrobků a výrobních možností, mají pouze informativní charakter. V katalogu nejsou prováděny aktualizace od data vydání.

Vydání: 04/2016



since 1889
"Great history. Excellent future"



**STROJÍRNY
POLDI**



POLOTOVARY NOŽŮ

PRŮŘEZ		MATERIÁL	TOLERANCE
 	223690	HSS HSSE Co5 HSSE Co10	h 14 h 14 h 13
	223691	HSS HSSE Co10	h 14 h 13
	223692	HSS HSSE Co10	h 14 h 13, h 8
	223693	HSS HSSE Co10	h 14 h 13 /DIN h 12/
	223694	HSS HSSE Co10	h 11 / k 13 h 11 / k 13
223695		HSS HSSE Co10	h 12 h 12

Jiné provedení, jako např. čela pod úhlem u nožů 223690, 223691, 223693, tolerance průřezu a délky, tvrdost, je možné po dohodě s výrobcem.

TOLERANCE DÉLKY	TVRDOST
± 2 mm	HSS min. 63 HRc
	HSSE Co5 min. 63 HRc
	HSSE Co10 min. 65 HRc



ČTVERCOVÝ PRŮŘEZ
kód 223690
TVAR B

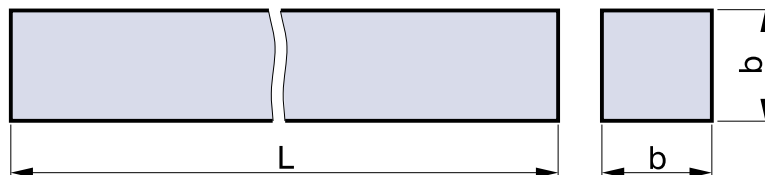

HSS
 HSSE Co5
 HSSE Co10

b x b	L								
	63	80	100	125	150	160	200	250	300
4x4									
5x5									
6x6									
7x7									
8x8									
10x10									
12x12									
14x14									
16x16									
18x18									
20x20									
25x25									
32x32									
40x40									

Rozměry v palcích

b x b	L							
	2 1/2	3	4	5	6	8	10	12
5/32x5/32								
3/16x3/16								
1/4x1/4								
5/16x5/16								
3/8x3/8								
7/16x7/16								
1/2x1/2								
5/8x5/8								
3/4x3/4								
1x1								
1 1/4x1 1/4								



ZPŮSOB OBJEDNÁVÁNÍ

Polotovar nože 223690, b x b x L, materiál, počet kusů

OBDELNÍKOVÝ PRŮŘEZ
kód 223691
TVAR D

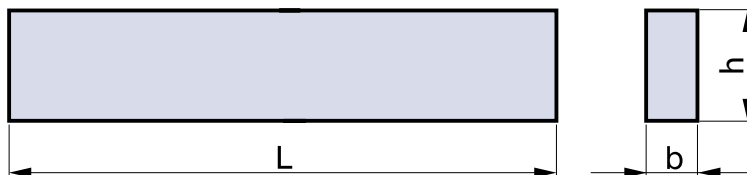

HSS
 HSSE Co10

h x b	L						
	63	80	100	125	150	160	200
6x4							
8x2							
3							
4							
5							
10x3							
4							
5							
6							
8							
12x3							
4							
5							
6							
8							
10							
14x3							
4							
5							
6							
8							
10							
15x3							
4							
5							
6							
8							
10							
12							
16x3							
4							
5							
6							
8							
10							
12							
18x3							
4							

OBDELNÍKOVÝ PRŮŘEZ

kód 223691

TVAR D

DRŽÁKY NOŽŮ

SOUSTRUŽNICKÉ NOŽE

REVOLVEROVÉ NOŽE

OBRAŽECÍ NOŽE A DRŽÁKY

HOBLOVAČÍ NOŽE

NOŽE PRO SOUŘADNICOVÉ
VYVŘTÁVAČKY

h x b	L						
	100	125	150	160	200	250	300
18x5							
6							
8							
10							
12							
20x3							
4							
5							
6							
8							
10							
12							
14							
16							
25x5							
6							
8							
10							
12							
16							
20							
30x6							
8							
10							
12							
15							
20							
25							
32x6							
8							
10							
12							
16							
40x6							
8							
10							
12							
50x8							
10							
12							

POZNÁMKA

Po dohodě s výrobcem možno dodávat i rozměry v palcích.



ZPŮSOB OBJEDNÁVÁNÍ

Polotovar nože 223691, h x b x L, materiál, počet kusů

KRUHOVÝ PRŮŘEZ
kód 223692
TVAR A

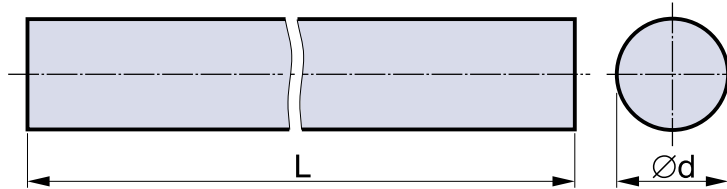

HSS
 HSSE Co10

Ød	L								
	40	63	80	100	125	150	160	200	250
3									
4									
5									
6									
8									
10									
12									
14									
16									
18									
20									
25									
30									

POZNÁMKA

Po dohodě s výrobcem možno dodávat i rozměry v palcích.

ZPŮSOB OBJEDNÁVÁNÍ

Polotovar nože 223692, d x L, materiál, počet kusů (u HSSE Co10 také tolerance)



PRAVIDELNÝ LICHOBĚŽNÍKOVÝ PRŮŘEZ

kód 223693

TVAR E

223693

DIN 4964 TVAR E

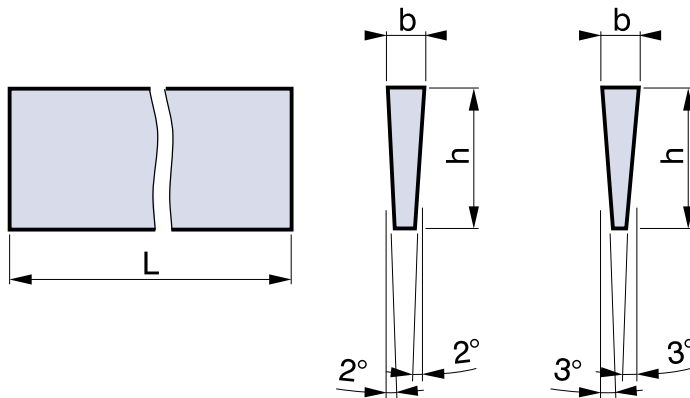

HSS
HSSE Co10

h x b	L						
	80	100	125	150	160	200	250
6x1,6							
8x2							
10x2,5							
12x3							
15x3							
15x4							
16x3							
16x4							
18x3							
18x4							
20x3							
20x4							
20x5							
25x5							
25x6							
32x8							
40x10							

POZNÁMKA

Po dohodě s výrobcem možno dodávat i rozměry v palcích.



ZPŮSOB OBJEDNÁVÁNÍ

Polotovar 223693 nebo DIN 4964 tvar E, h x b x L, materiál, počet kusů

NEPRAVIDELNÝ LICHOBĚŽNÍKOVÝ PRŮŘEZ
kód 223694

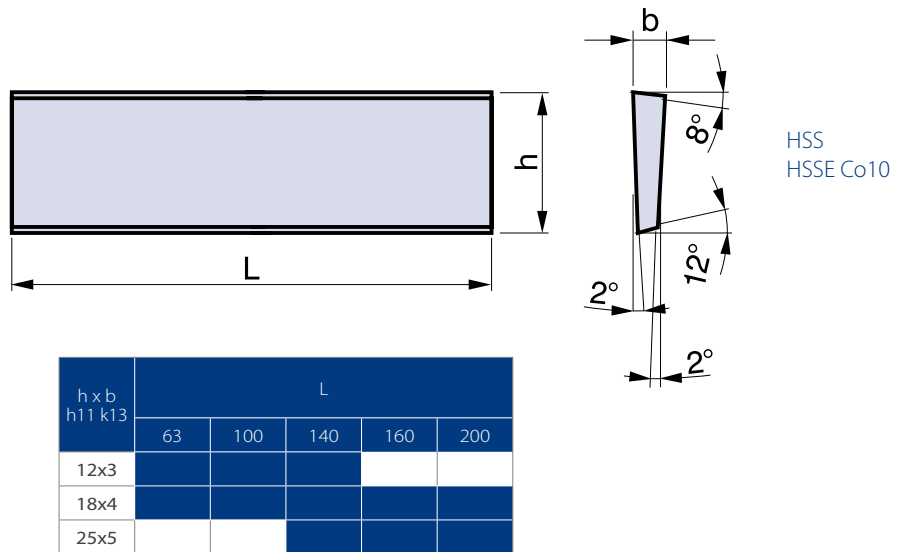

ZPŮSOB OBJEDNÁVÁNÍ

Upichovací nůž 223694, h x b x L, materiál, počet kusů



NEPRAVIDELNÝ LICHOBĚŽNÍKOVÝ PRŮŘEZ
kód 223695
INDEX-FORM

HSS
HSSE Co10

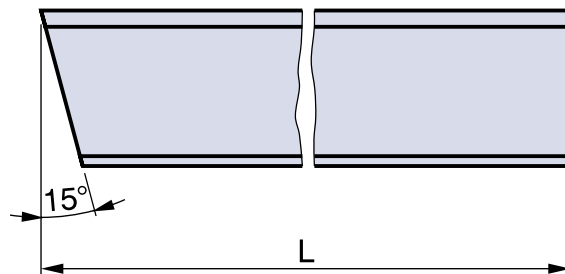

h x b	L					
	85	100	120	140	160	200
12x3						
12x4						
12x5						
16x3						
16x4						
16x6						
18x4						
18x6						
20x3						
20x4						
20x5						
20x6						
25x4						
25x6						

INDEX

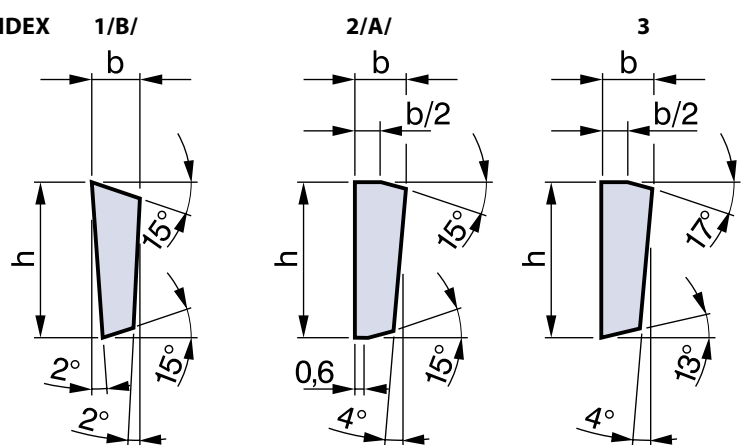

POZNÁMKA

Po dohodě s výrobcem možno dodávat i rozměry v palcích.

ZPŮSOB OBJEDNÁVÁNÍ

Upichovací nůž 223695, h x b x L, INDEX, materiál, počet kusů





DRŽÁKY NOŽŮ



DRŽÁK NA POLOTOVARY NOŽŮ
kód 241598
Tvar nože B



ČÍSLO	b x b
0	4 - 6
1	7 - 9
2	10 - 12
3	13 - 16
4	17 - 19

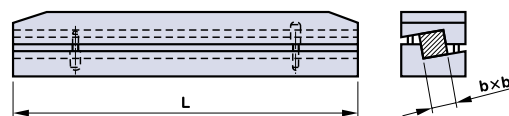

ZPŮSOB OBJEDNÁVÁNÍ 
Držák 241598, číslo, počet kusů

DRŽÁK NA POLOTOVARY NOŽŮ
kód 241599
Tvar nože E



ČÍSLO	h
1	6
2	8 - 10
3	12 - 18
4	20 - 25
5	32 - 40

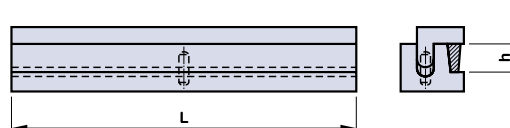

ZPŮSOB OBJEDNÁVÁNÍ 
Držák 241599, číslo, počet kusů.

DRŽÁK NA UPICHOVACÍ NOŽE
PRO NOŽE 223695



ČÍSLO	h
1	12
2	16
3	18
4	20
5	25
6	1/2'
7	5/8'
8	3/4'
9	7/8'
10	1'



ZPŮSOB OBJEDNÁVÁNÍ 
Držák pro nože 223695, číslo, počet kusů



SOUSTRUŽNICKÉ NOŽE



ZPŮSOB OBJEDNÁVÁNÍ

Soustružnický nůž - kód, h x b x L, počet kusů

UBÍRACÍ NŮŽ PŘÍMÝ – 45°
kód 223514 - pravý
kód 223515 - levý



h	b	L	PROVEDENÍ
10	10	90	celistvé
12	12	100	
16	16	110	svařované na tupo nebo s břitovou destičkou HSS
20	20	125	
25	25	140	
32	32	170	
40	40	200	
50	32	240	

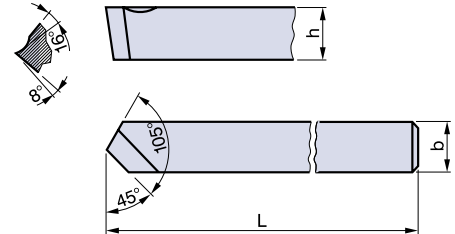

UBÍRACÍ NŮŽ PŘÍMÝ – 60°
kód 223516 - pravý
kód 223517 - levý



h	b	L	PROVEDENÍ
10	10	90	celistvé
12	12	100	
16	16	110	svařované na tupo nebo s břitovou destičkou HSS
20	20	125	
25	25	140	
32	32	170	
40	40	200	
50	32	240	

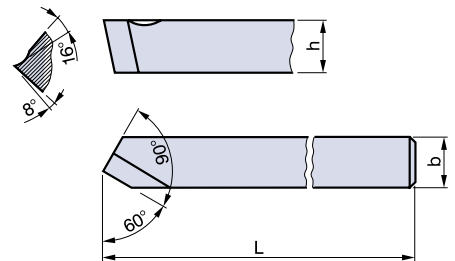

UBÍRACÍ NŮŽ OHNUTÝ
kód 223520 - pravý
kód 223521 - levý



h	b	n	L	PROVEDENÍ
10	10	6	90	celistvé
12	12	8	100	
16	16	10	110	svařované na tupo nebo s břitovou destičkou HSS
20	20	14	125	
25	25	18	140	
32	32	22	170	
40	40	28	200	
50	32	22	240	

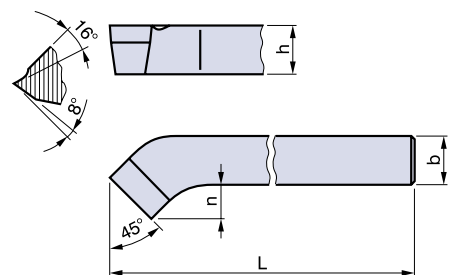

SOUSTRUŽNICKÉ NOŽE



UBÍRACÍ NŮŽ STRANOVÝ
kód 223524 - pravý
kód 223525 - levý

h	b	n	L	PROVEDENÍ
10	10	4	90	celistvé
12	12	5	100	
16	16	6	110	svařované na tupo nebo s břitovou destičkou HSS
20	20	8	125	
25	25	10	140	
32	32	12	170	
40	40	14	200	

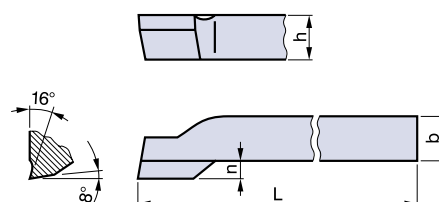

NABÍRACÍ NŮŽ
kód 223530



h	b	L	PROVEDENÍ
20	12	125	svařované na tupo nebo s břitovou destičkou HSS
25	16	140	
32	20	170	
40	25	200	
50	32	240	

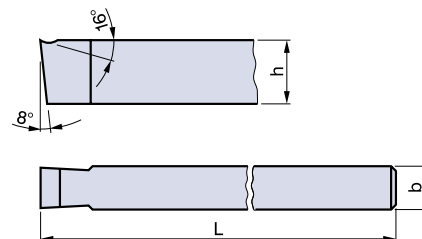

HLADÍCÍ NŮŽ
kód 223532



h	b	L	PROVEDENÍ
16	10	110	celistvé
20	12	125	svařované na tupo nebo s břitovou destičkou HSS
25	16	140	
32	20	170	
40	25	200	

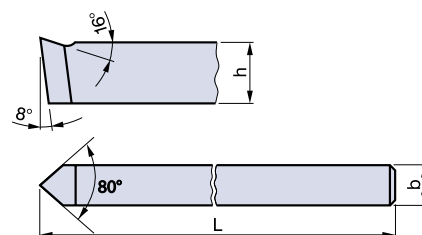

ROHOVÝ NŮŽ

kód 223534 - pravý
kód 223535 - levý



h	b	n	L	PROVEDENÍ
10	10	5	90	celistvé
12	12	6	100	
16	16	8	110	svařované na tupo nebo s břitovou destičkou HSS
20	20	10	125	
25	25	12	140	
32	32	16	170	
40	40	20	200	
16	10	5	110	celistvé
20	12	6	125	svařované na tupo nebo s břitovou destičkou HSS
25	16	8	140	
32	20	10	170	
40	25	12	200	

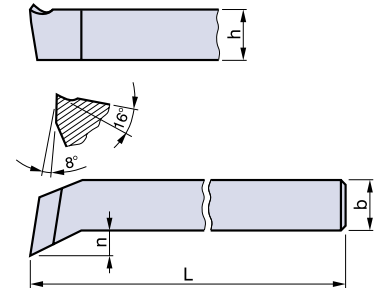

VNITŘNÍ UBÍRACÍ NŮŽ

kód 223540



h	b	Ød1	n	l	L	PROVEDENÍ
25	25	20	10	125	300	svařované na tupo nebo s břitovou destičkou HSS
32	32	25	12	160	355	

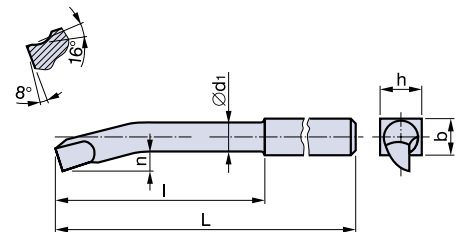

VNITŘNÍ UBÍRACÍ NŮŽ

kód 223542



h	b	Ød1	n	l	L	PROVEDENÍ
10	10	8	3	40	100	celistvé
12	12	10	3,5	50	125	
16	16	13		4	63	140
20	20	16	80		160	

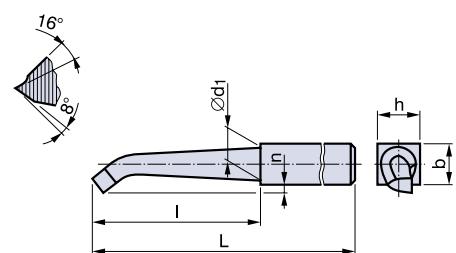

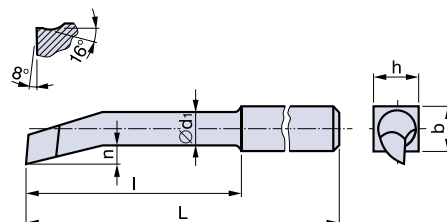

VNITŘNÍ ROHOVÝ NŮŽ
kód 223544

h	b	Ød1	n	l	L	PROVEDENÍ
25	25	20	10	125	300	svařované na tupo nebo s břitovou destičkou HSS
32	32	25	12	160	355	

VNITŘNÍ ROHOVÝ NŮŽ
kód 223548

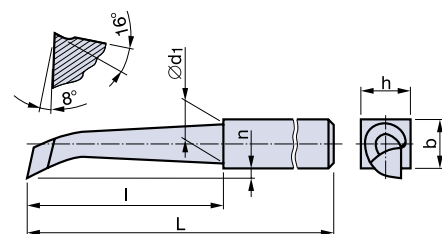
h	b	Ød1	n	l	L	PROVEDENÍ
10	10	8	3	40	100	celistvé
12	12	10	3,5	50	125	
16	16	13		63	140	svařované na tupo nebo s břitovou destičkou HSS
20	20	16	4	80	160	

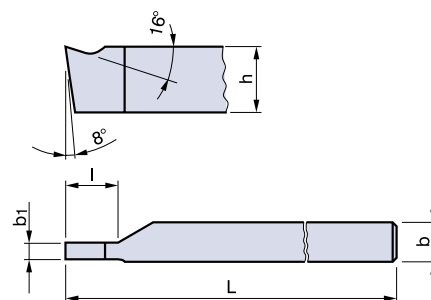

ZAPICHOVACÍ NŮŽ
kód 223550 - pravý
kód 223551 - levý

h	b	l	b1	L	PROVEDENÍ
16	10	14	4	110	celistvé
20	12	16	5	125	
25	16	20	6	140	
32	20	25	8	170	svařované na tupo
40	25	32	10	200	
50	32	40	12	240	
					s břitovou destičkou HSS



VNITŘNÍ ZAPICHOVACÍ NŮŽ
kód 223552

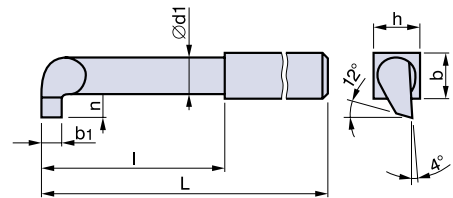

h	b	Ød1	l	n	b1	L	PROVEDENÍ
10	10	8	50	6	4	150	celistvé
12	12	10	63	8	5	180	
16	16	14	80	10	6	220	svařované na tupo
20	20	18	100	12	8	250	
25	25	22	125	16	10	300	
32	32	30	160	18	12	355	

ZAOBLOVACÍ NŮŽ
kód 223562 - pravý
kód 223563 - levý

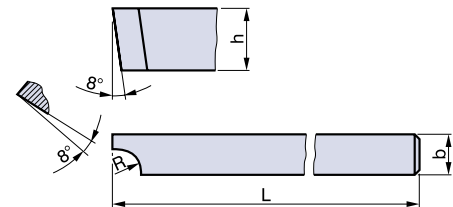
h	b	R	L	PROVEDENÍ	
16	10	2	110	celistvé	
		2,5			
		3			
		4			
20	12	5	125	svařované na tupo nebo s břitovou destičkou HSS	
		6			
		8			
25	16	10	140		
32	20	12	170		
40	25	16	200		
50	32	18	240		

ZAPICHOVACÍ NŮŽ NA ZÁPICHY VNITŘNÍCH ZÁVITŮ
kód 223586

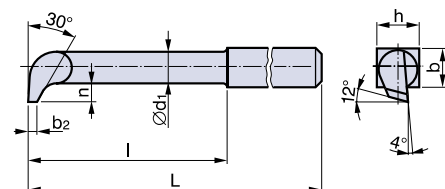

h	b	Ød1	l	n	b2	L	PROVEDENÍ
10	10	8	50	6	2	150	celistvé
12	12	10	63	8	2,5	180	



SOUSTRUŽNICKÉ NOŽE

NŮŽ NA KLÍNOVÉ DRÁŽKY ŘEMENIC
kód 223590

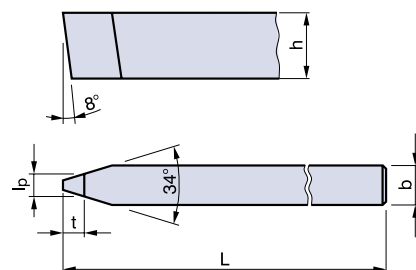
h	b	lp	t	L	PROVEDENÍ
20	12	8,5	9	125	svařované na tupo nebo s břitovou destičkou HSS
25	16	11	11	140	
32	20	14	14	170	
40	25	19	19	200	

ZÁVITOVÝ NŮŽ
kód 223312 - pravý
kód 223313 - levý

h	b	l	b1	L	PROVEDENÍ
16	10	14	4	110	celistvé
20	12	16	5	125	svařované na tupo
25	16	20	6	140	
32	20	25	8	170	

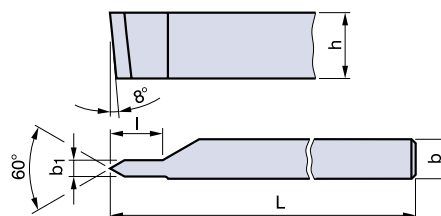
NŮŽ NA VNITŘNÍ ZÁVITY
kód 223316

h	b	Ød1	l	n	b1	L	Provedení
10	10	8	40	6	4	100	celistvé
12	12	10	50	8	5	125	
16	16	14	63	10	6	140	svařované na tupo
20	20	18	80	12	8	160	
25	25	22	100	16	10	200	
32	32	30	125	18	12	250	

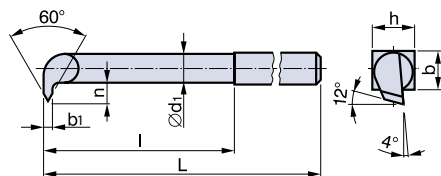





REVOLVEROVÉ NOŽE



ZPŮSOB OBJEDNÁVÁNÍ

Revolverový nůž - kód, h x b x L (ød x L), počet kusů

UBÍRACÍ NŮŽ PŘÍMÝ - 15°
kód 223910 - pravý
kód 223911 - levý



$\varnothing d$ h 9	L	n
8	25	1,6
	32	
10	40	2,5
	63	
12	63	3,2
15	50	4
	80	
16	50	4
	80	
20	63	5
	100	

h h 11	b h 11	L	n
10	10	40	2,5
		63	
12	12	50	3,2
		80	
16	16	63	4
		100	
		80	
20	20	80	5
		125	

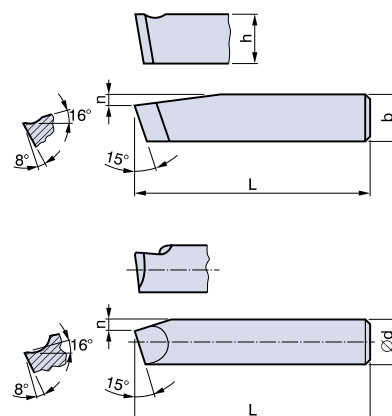

UBÍRACÍ NŮŽ PŘÍMÝ - 30°
kód 223912 - pravý
kód 223913 - levý



$\varnothing d$ h 9	L	n
8	25	1,6
	32	
10	40	2,5
	63	
12	63	3,2
15	50	4
	80	
16	50	4
	80	
20	63	5
	100	

h h 11	b h 11	L	n
10	10	40	3
		63	
12	12	50	3,5
		80	
16	16	63	4
		100	
		80	
20	20	80	6
		125	

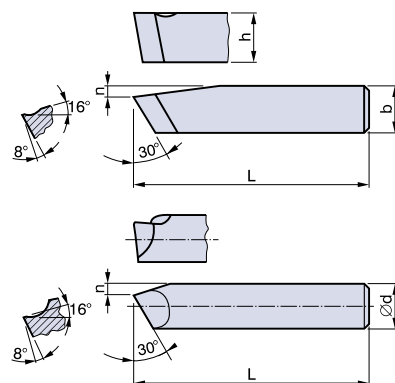

UBÍRACÍ NŮŽ PŘÍMÝ-45°
kód 223914 - pravý
kód 223915 - levý



$\varnothing d$ h 9	L	n
8	32	2
10	40	2,5
	63	
12	63	3
15	50	4
	100	
16	50	4
	100	
20	63	5
	125	

h h 11	b h 11	L	n
10	10	40	4,5
		63	
12	12	50	5
		80	
		80	
16	16	63	6
		100	
		100	
20	20	80	8
		125	

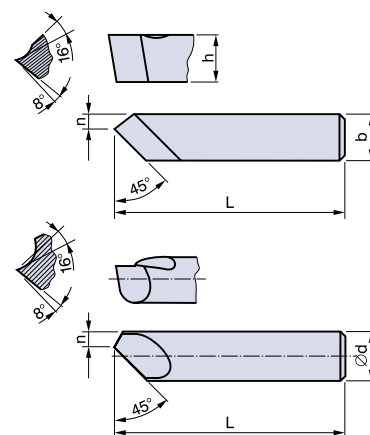

REVOLVEROVÉ NOŽE



UBÍRACÍ NŮŽ PŘÍMÝ - 60°
 kód 223916 - pravý
 kód 223917 - levý

Ød h9	L
8	32
10	40
	63
12	63
	63
15	63
	100
16	63
	100
20	63
	125

h h11	b h11	L	n
10	10	40	5
		63	
12	12	50	6
		80	
16	16	63	8
		100	
20	20	80	10
		125	

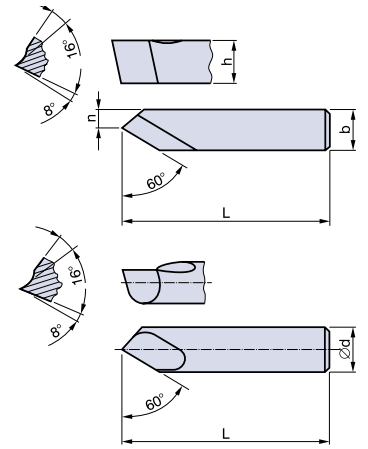

ZAPICHOVACÍ NŮŽ
 kód 223920 - pravý
 kód 223921 - levý

h h11	b h11	L	l	b ₁
10	10	50	10	2,5
12	12	63	12	3
16	16	80	15	4
20	20	100	18	5

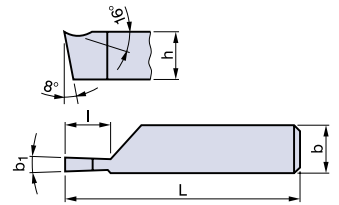

VNITŘNÍ ZAPICHOVACÍ NŮŽ
 kód 223922 - pravý
 kód 223923 - levý

Ød h9	L	n	b ₂
12	63	8	1,5
	63		
15	63	10	2,5
	100		
16	63	10	2,5
	100		
20	80	12	2,5
	125		

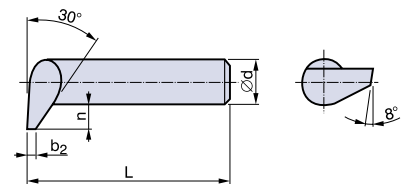



UBÍRACÍ NŮŽ STRANOVÝ
kód 223926 - pravý
kód 223927 - levý

$\varnothing d$ h 9	L
8	32
10	40
	63
12	63
	50
15	100
	50
16	100
	63
20	125

h h 11	b h 11	L
10	10	40
		63
12	12	50
		80
16	16	63
		100
20	20	80
		125

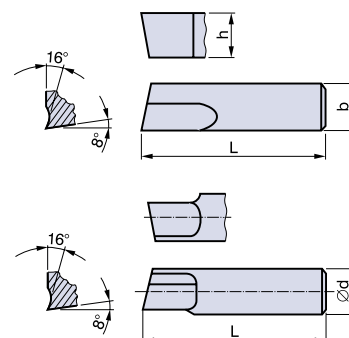

NABÍRACÍ NŮŽ
kód 223930

$\varnothing d$ h 9	L	b_2
8	25	7
	32	
10	40	9
	63	
12	63	10,5
	50	
15	100	12
	50	
16	100	13
	63	
20	125	16

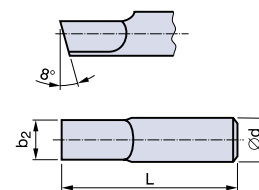

HLADÍCÍ NŮŽ
kód 223932

$\varnothing d$ h 9	L
8	25
	32
10	40
	63
12	63
	50
15	100
	50
16	100
	63
20	125

h h 11	b h 11	L
10	10	40
		63
12	12	50
		80
16	16	63
		100
20	20	80
		125

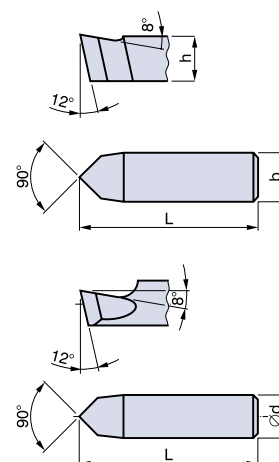



ROHOVÝ NŮŽ
kód 223934 - pravý
kód 223935 - levý

h h 11	b h 11	L	n
10	10	40	2
		63	
12	12	50	2,5
		80	
16	16	63	3,5
		100	
20	20	80	5
		125	

Ød h 9	L	N
12	63	2,5
	100	
15	63	3,5
	100	
16	63	3,5
	100	
20	80	5
	125	

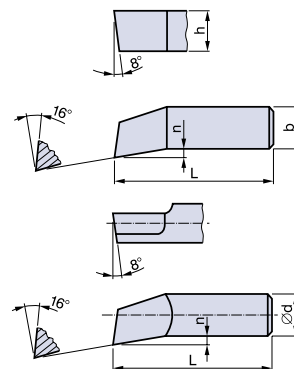

VNITŘNÍ UBÍRACÍ NŮŽ
kód 223940 - pravý
kód 223941 - levý

Ød h 9	L	Ød ₁	l	n
12	80	8	30	2
15	100	10	40	2,5
16	100	10	40	2,5
20	125	12	50	3,5

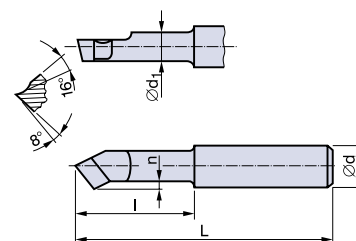

VNITŘNÍ ROHOVÝ NŮŽ
kód 223944 - pravý
kód 223945 - levý

Ød h 9	L	Ød ₁	l	n
12	80	8	30	2
15	100	10	40	2,5
16	100	10	40	2,5
20	125	12	50	3

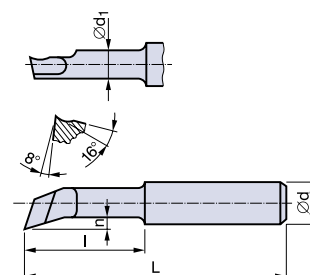



VNITŘNÍ ŠIROKÝ NŮŽ
kód 223946 - pravý
kód 223947 - levý

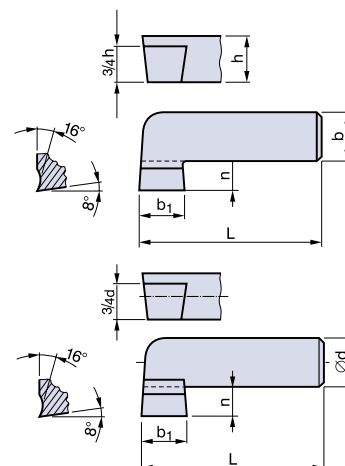

h h 11	b h 11	L	b ₁	n
12	12	50	12	10
		80		
16	16	63	15	12
		100		
20	20	80	20	16
		125		

Ød h 9	L	b ₁	n
12	63	12	10
	80		
15	63	15	12
	100		
16	63	15	12
	100		
20	80	20	16
	125		

UPICHOVACÍ NŮŽ DO DRŽÁKU
kód 223554 - pravý
kód 223555 - levý

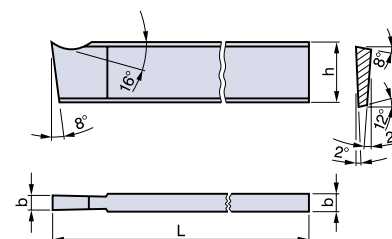

b	h	L
3	12	63
		100
4	18	63
		140
5	25	160

UPICHOVACÍ NŮŽ DO DRŽÁKU
kód 223558

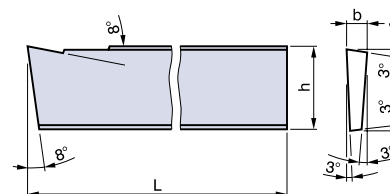

b h 12	h h 11	L
1,6	6	80
		100
2	8	80
		100
2,5	10	80
		100
3	12	100
		160
4	16	80
		100
		160

b h 12	h h 11	L
4	16	200
		80
5	20	100
		160
6	25	200
		80
8	32	100
		160
10	40	200
		160

REVOLVEROVÉ NOŽE

UPICHOVACÍ NŮŽ DO DRŽÁKU
kód 223589

b h 12	h h 12	L	b ₁	h ₁
2,5	20	160	1,7	5
3			2,2	
3,5			2,7	
4			3,2	
4	25	200	3,1	6,5
5			4,1	

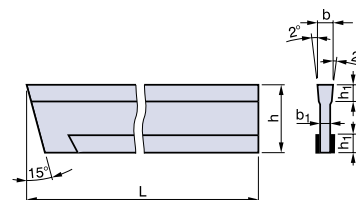





OBRÁŽECÍ NOŽE A DRŽÁKY

223682 16 H85
223681 289222



ZPŮSOB OBJEDNÁVÁNÍ

Obrážecí nůž 223680, \varnothing d, počet kusů
Obrážecí nůž 223681 (223682, 223683), b x h x L, počet kusů
Držák obrážecího nože 241025, d, počet kusů
Držák obrážecího nože 241026, a, počet kusů

HRUBOVACÍ NŮŽ
kód 223680

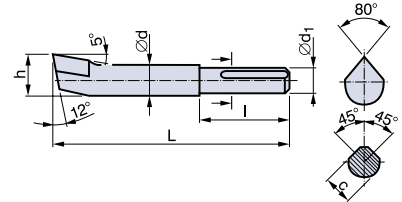

Ø d	L	h	Ø d ₁ d11	l	c
14	105	18	12	40	11,6
20	150	25	18	56	17,4
25	220	32	22	80	21,2
32	280	40	30	100	29,0

DRÁŽKOVACÍ NŮŽ
kód 223681

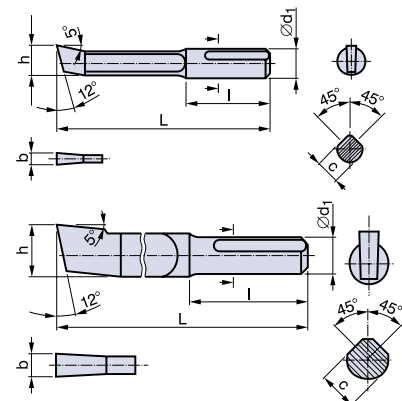

b f8	h	L	Ø d ₁ d11	l	c
2	6,5	70	12	40	11,6
3	7,5	75			
4	9	90			
5	11	100			
6	16	130			
7	17	140	18	56	17,4
8	19	150			
10	24	165	18	56	17,4
12	27	200			
14	28	220			
16		240			
18	30	250	22	80	21,2
20		260			

DRÁŽKOVACÍ NŮŽ PŘÍČNÝ
kód 223682

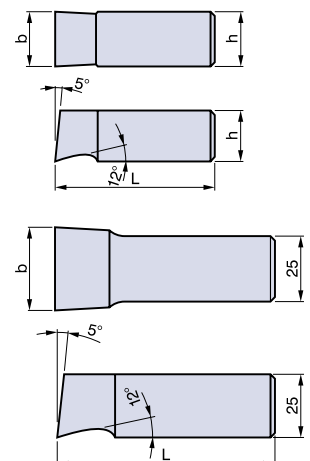

b f8	h h 11	L
8	8	26
10	10	
12	12	32
14	14	
16	16	40
18	18	
20	20	50
22	22	
25	25	55
28	25	
32	25	65
36		
40		
	70	75

OBRÁŽECÍ NŮŽ DVOUBŘITÝ
kód 223683



b	L	∅ d, d11	l	c
8	85	12	40	11,2
10	95			
12	105	18	56	16,8
16	140			
20	180	22	80	20,4
25	220			
32	280	30	100	28

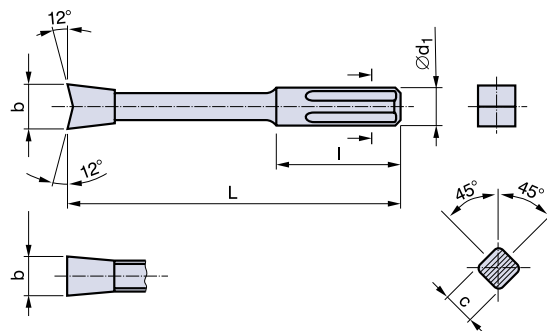

DRŽÁK OBRÁŽECÍHO NOŽE

kód 241025

Kód nožů 223680

223681

223683



b x b	d	L
25x25	12	140
32x32	18	180
40x40	22	220
50x50	30	280

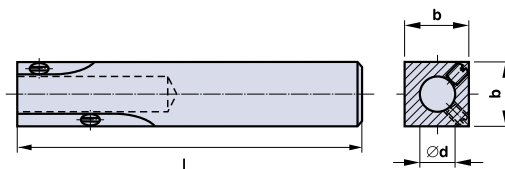

DRŽÁK OBRÁŽECÍHO NOŽE

kód 241026

Kód nože 223682



b x b	a	e	∅ d	L	l ₁
25x25	8	8	22	300	150
	10	10	22		
	12	10	24		
32x32	14	12	30	355	200
	16	12	30		
40x40	18	15	38	400	220
	20	15	38		
50x50	22	20	48	450	250
	25	20	48		

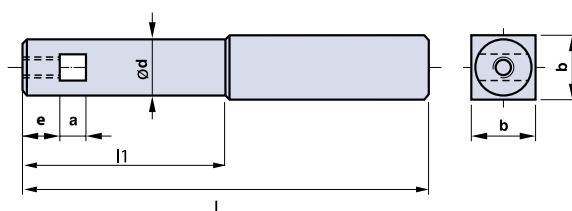

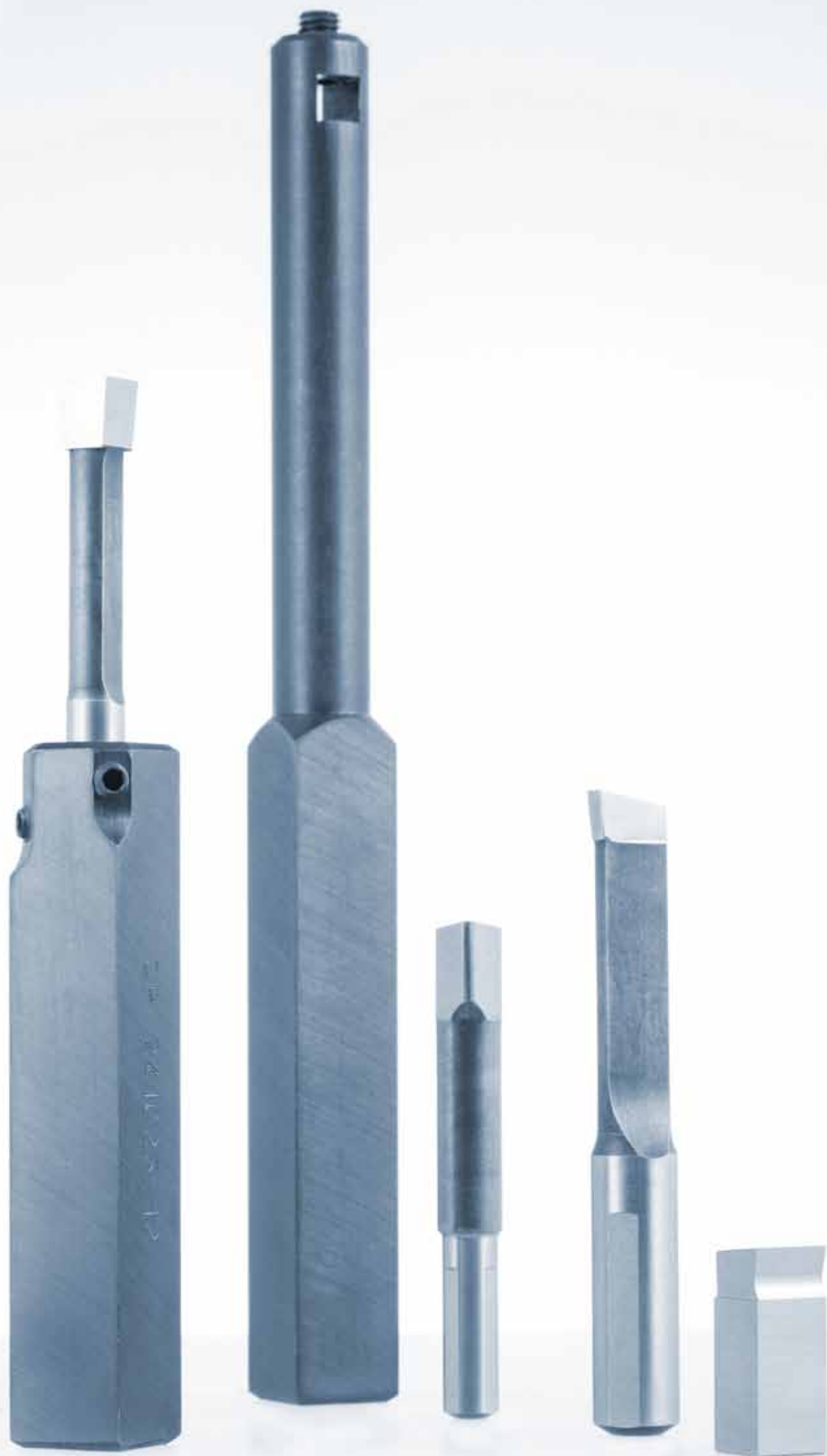



HOBLOVACÍ NOŽE



ZPŮSOB OBJEDNÁVÁNÍ

Hoblovací nůž - kód, h x b x L, počet kusů



UBÍRACÍ NŮŽ
kód 223650 - pravý
kód 223651 - levý

h	b	L
25	16	250
32	20	300
40	25	400
50	32	500
63	40	500

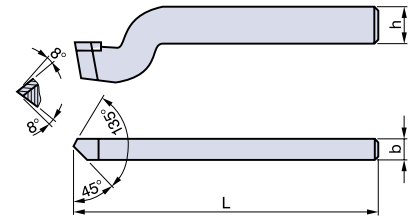

ROHOVÝ NŮŽ
kód 223652 - pravý
kód 223653 - levý

h	b	L	n
25	16	250	7
32	20	300	8
40	25	400	10
50	32	500	12
63	40	500	16

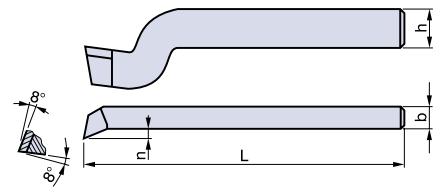

HLADÍCÍ NŮŽ
kód 223654

h	b	L	b ₁
25	16	250	20
32	20	300	25
40	25	400	32
50	32	500	40
63	40	500	50

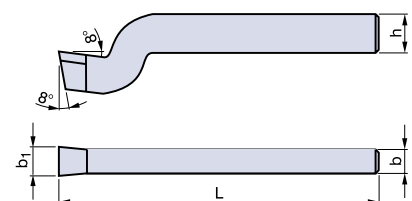

HOBLOVACÍ NOŽE



ZAPICHOVACÍ NŮŽ
kód 223655

h	b	L	b ₁
25	16	250	6
32	20	300	7
40	25	400	8
50	32	500	10
63	40	500	12,5

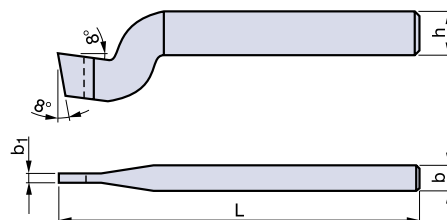





NOŽE PRO SOUŘADNICOVÉ VYVRTÁVAČKY



ZPŮSOB OBJEDNÁVÁNÍ

Nůž pro souřadnicové vyvrtávačky kód, objednáací číslo,
počet kusů

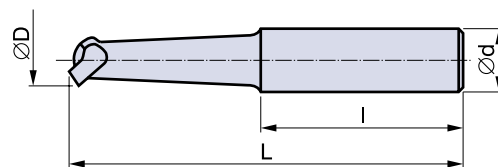
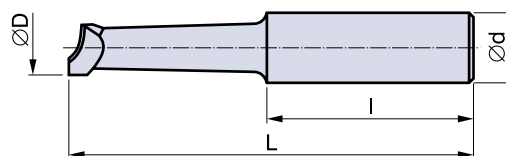
UBÍRACÍ NŮŽ
kód 221710

ROHOVÝ NŮŽ
kód 221711

OBJEDNACÍ ČÍSLO	Ø D	Ø d	L	l
10	4	4	40	20
11		6	50	25
12		8		
13		10	60	30
14	5	8	50	25
15		10	60	30
16	6	6	50	
17		8	60	
18		10	70	35
19	12			
20	9	6	50	25
21		8	60	30
22		10	70	35
23		12		
25	13	8	60	30
26		10		
27		12		
30	15	8	70	53
31		10	90	40
32		12	80	35
35	9	70		
36	13	16	90	
37	15		110	50



since 1889

"Great history. Excellent future"

Karl Wittgenstein

STROJÍRNY POLDI, a.s.

Dubská 243, 272 03 Kladno – Dubí, Česká republika
Tel.: +420 313 115 110, Fax: +420 312 247 445
info@strojpolodi.com

Member of

JET INVESTMENT

MANAGEMENT



15 minut od Letiště
Václava Havla Praha

www.strojpolodi.com