



6

**NÁSTROJOVÉ DRŽÁKY, HROTY, KLEŠTINY A NOŽOVÉ HLAVY**



## Provedení pro frézovací stroje a obráběcí centra



## Stopky držáků pro konvenční a NC stroje

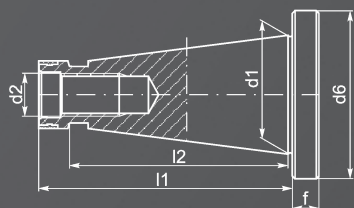

### SK 30 i SK 50

S vnitřním závitem pro upínací šroub

	SK 30	SK 50
<b>l1</b>	70	130
<b>l2</b>	51,4	115
<b>d1</b>	31,75	69,85
<b>d2</b>	M12	M24
<b>d6</b>	50	97,5
<b>f</b>	8	12

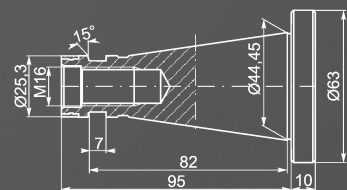

### SK 40

S vnitřním závitem pro upínací šroub, pro ruční výměnu nástrojů, varianta QC s drážkou pro automatickou výměnu

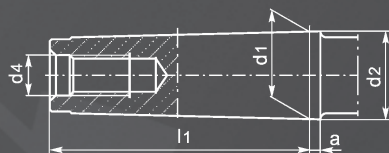

### MK 2 - MK 6

S vnitřním závitem pro upínací šroub

	MK 2	MK 3	MK 4	MK 5	MK 6
<b>l1</b>	64	81	102,5	129,5	182
<b>d1</b>	17,780	23,825	31,267	44,399	63,348
<b>d2</b>	18	24,1	31,6	44,7	63,8
<b>d4</b>	M10	M12	M16	M20	M24
<b>a</b>	5	5	6,5	6,5	8

## Stopky držáků pro NC stroje a CNC obráběcí centra

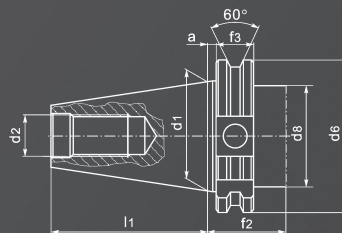

**Varianta A:** bez průchozího otvoru  
**Varianta AD:** s průchozím otvorem v ose upínače pro přívod chladiva k nástroji  
**Varianta B:** pro boční přívod chladiva

	SK 30	SK 40	SK 50
<b>l1</b>	47,80	68,40	101,75
<b>d1</b>	31,75	44,45	69,85
<b>d2</b>	M12	M16	M24
<b>d6</b>	50	63,55	97,50
<b>d8</b>	45	50	80
<b>f2</b>	35	35	35
<b>f3</b>	19,1	19,1	19,1
<b>a</b>	3,2	3,2	3,2

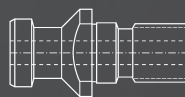

### Tažné čepy DIN 69872

Typ A a B

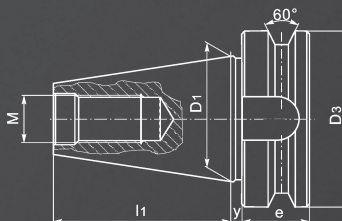

### Tažné čepy MAS 403-BT

Typ A a B

	SK 30	SK 40	SK 50
<b>l1</b>	48,4	65,4	101,8
<b>D1</b>	31,75	44,45	69,85
<b>D3</b>	46	63	100
<b>M</b>	M12	M16	M24
<b>e</b>	20	25	35
<b>y</b>	2	2	3

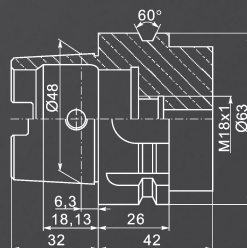

### Varianta A

Pro CNC obráběcí centra, frézovací stroje a speciální stroje s automatickou výměnou nástrojů  
 Kanál v ose upínače pro přívod chladiva



Trubička pro přívod chladiva

<b>I</b>	<b>OTOČNÉ HROTY · KUŽEL MORSE · DIN 228</b>	<b>271-277</b>	<b>X</b>	<b>VRTACÍ SKLÍČIDLA A PŘÍSLUŠENSTVÍ</b>	<b>324-326</b>
<b>II</b>	<b>PEVNÉ HROTY · KUŽEL MORSE · DIN 228</b>	<b>277-279</b>	<b>XI</b>	<b>REDUKČNÍ POUZDRA A POUZDRA PRO SOUSTRUŽNICKÉ DRŽÁKY</b>	<b>327-330</b>
<b>III</b>	<b>UPÍNAČE PRO AUTOMATICKOU VÝMĚNU · DIN 69871</b>	<b>280-289</b>	<b>XII</b>	<b>KLEŠTINY PRO UPÍNÁNÍ NÁSTROJŮ</b>	<b>331-333</b>
<b>IV</b>	<b>UPÍNAČE PRO AUTOMATICKOU VÝMĚNU · MAS 403-BT</b>	<b>290-299</b>	<b>XIII</b>	<b>KLEŠTINY PRO UPÍNÁNÍ MATERIÁLU</b>	<b>334-337</b>
<b>V</b>	<b>UPÍNAČE A TRNY PRO RUČNÍ VÝMĚNU · DIN 2080</b>	<b>300-313</b>	<b>XIV</b>	<b>NOŽOVÁ HLAVA PRO RYCHLOVÝMĚNNÉ DRŽÁKY</b>	<b>338-339</b>
<b>VI</b>	<b>UPÍNAČE PRO AUTOMATICKOU VÝMĚNU · HSK-A · DIN 69893-A</b>	<b>310-315</b>	<b>XV</b>	<b>NÁHRADNÍ DÍLY A PŘÍSLUŠENSTVÍ</b>	<b>340-344</b>
<b>VII</b>	<b>UPÍNAČE A TRNY · KUŽEL MORSE · DIN 228</b>	<b>316-319</b>			
<b>VIII</b>	<b>UPÍNAČE A TRNY S VÁLCOVOU STOPKOU · DIN 1835</b>	<b>320-321</b>			
<b>IX</b>	<b>UPÍNAČE A TRNY S AXIÁLNÍM NASTAVENÍM · DIN 6327</b>	<b>322-323</b>			

## SEZNAM VÝROBKŮ DLE TYPU

TYP	STRANA	TYP	STRANA	TYP	STRANA	TYP	STRANA	TYP	STRANA	TYP	STRANA
1226	329	1830	323	5362	325	7388 AD+B	293	7629	291	8721	278
1246	329	1831	323	5363	324	7430	317	7630	288	8725	278
1247	330	1833	323	5365	326	7450	318	7632	298	8726	278
1248	330	1875	330	5366	319	7510	322	7634	315	8727	278
1249	330	1911	341	5367	319	7520	32	7655 A	286	8727S	278
1313	315	2190	309	5370-B	326	7600-KPL	333	7656	296	8728	279
1606 AD	285	2191 A	289	5370-J	326	7600-PL	333	7657	307	8730	279
1613 AD	295	2192	299	5373-B	325	7616	300	7660	286	8731	279
1616	303	2824	303	5373-J	325	7616-S	300	7661	296	8731	279
1650	308	2826	295	5374-B	325	7616-KPL	301	7662	309	8735	279
1653	308	2827 A	285	5374-J	325	7616-PL	301	7668	294	8740	279
1655	308	2850	309	5390-B	326	7616-S PL	301	7669	284	8809	272
1657	307	2852	289	5390-J	326	7617 AD	280	7711	316	8810	272
1660	297	2854	299	5391	314	7617 AD+B	280	7711-KPL	317	8811	273
1661	296	2856	314	5392	314	7617-S AD	281	7711-PL	317	8811 R	270
1661 AD+B	297	2858	318	6610	318	7617-S AD+B	281	7720	317	8812 R	270
1663	297	3000-5C	334	6680	318	7617-KPL	281	7721	317	8813 R	270
1676	307	3000-5C-KPL	334	7175	304	7617-KP	281	7812	320	8814	273
1679	307	3010-171E	335	7178	304	7617-S PL	281	7812-KPL	320	8814 R	271
1681 AD	286	3010-173E	336	7181	305	7618	327	7813	322	8814 NC	271
1681 AD+B	287	3010-185E	337	7184	305	7618-KPL	331-332	7815	321	8815 NC	271
1682 A	287	4414	338	7186	306	7620	301	7872	313	8815F	271
1684 A	287	4494	339	7188	306	7622	321	7885	311	8815	273
1694	297	4495	339	7272	340	7624	292	7886	311	8816	273
1694 AD+B	297	4496	339	7275	340	7624 AD+B	292-293	7887	310	8823	272
1695 AD	287	4497	339	7285	340	7625 AD	282	7888	312	8824	272
1695 AD+B	287	4498	339	7301	284	7625 AD+B	282-283	7889	312	8825	276
1699	308	4499	339	7311	302	7626	290	7890	313	8825	276
1721	319	5133	324	7314	303	7626 AD+B	290	7891	314	8831	274
1751	327	5134	324	7332	302	7626-S	291	7892	313	8832	275
1754	327	5216	319	7361	294	7626-S AD+B	291	7895	312	8832-KPL	275
1761	328	5217	319	7369 AD+B	283	7626-KPL	291	8410	276	8882	276
1764	328	5219	319	7369 A	284	7626-PL	291	8500	321	9882 A	289
1770	327	5310	318	7372	295	7626-S PL	291	8711	277	9882 B	289
1774	328	5348	326	7373 A	285	7627	301	8712	277	9883 A	299
1775	328	5361	324	7388	294	7628	281	8720	278	9883 B	299



## OTOČNÉ HROTY TYPU "R"

- Pro všeobecné použití
- Tělo hrotu je kalené a broušené
- Vysoká přesnost, nízká házivost
- Otáčky až do 7000 ot/min
- Max. hmotnost kusu do 5000 kg
- Životnost ložisek 2000 pracovních hodin

Radiální zatížení  
Životnost ložisek - 2000h

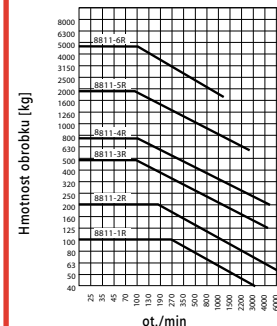

Axiální zatížení  
Životnost ložisek - 2000h

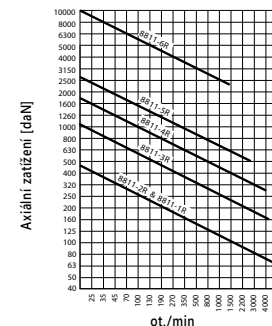

## 8811 R

- Soustružnické otočné hroty

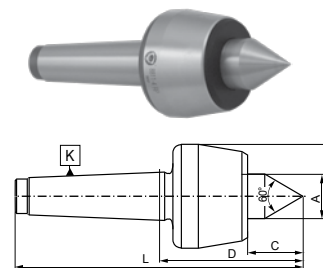

K MK	Max. hmotnost obrobku [kg]	Ot./min	Přesný Házivost max.	Přesný Kód výrobku	Standardní Házivost max.	Standardní Kód výrobku	A	B	C	D	L
1	100	7000	-	-	0,005	800006761	15	36,0	17,0	60,5	114
2	200	7000	0,003	800006762	0,005	800006763	20	45,0	23,5	64,5	128,5
3RL*	400	6300	0,003	800006766	0,005	800006623	22	50,0	27,5	70,0	151
3	500	5000	0,003	800006764	0,005	800006765	25	60,0	30,5	79,0	160
4	800	3800	0,003	800006767	0,005	800006624	32	70,0	40,0	101,5	204
5	2000	3000	0,003	800006768	0,005	800006625	40	90,0	49,5	128	257,5
6	3500	2600	-	-	0,010	800006769	50	105,0	57,5	152	334
6RC**	5000	1500	-	-	0,010	800006770	62,4	140,0	67,0	194	376

\* Tělo o menším průměru

\*\* Pro velká zatížení

Radiální zatížení  
Životnost ložisek - 2000h

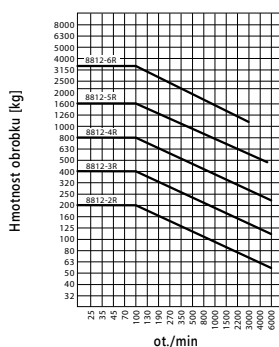

Axiální zatížení  
Životnost ložisek - 2000h

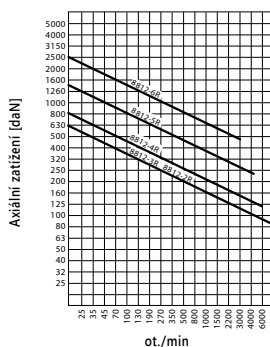

## 8812 R

- Soustružnické otočné hroty se zmenšeným tělesem

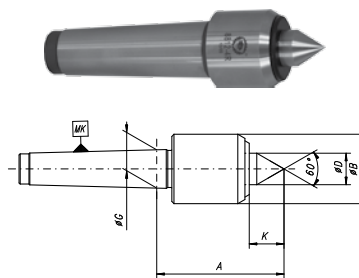

Kužel MK	Max. hmotnost obrobku [kg]	Ot./min	Házivost max.	Kód výrobku	A	B	D	G	K
2	200	7000	0,005	800006024	62	32	15	17,780	18
3	400	7000	0,005	800006705	62	34	15	23,825	18
4	800	6300	0,005	800006706	75,5	42	20	31,267	25
5	1600	4300	0,01	800006707	104	58	30	44,399	34
6	3500	3000	0,02	800006708	143	80	42	63,348	49

Radiální zatížení  
Životnost ložisek - 2000h

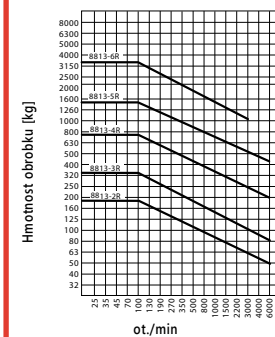

Axiální zatížení  
Životnost ložisek - 2000h

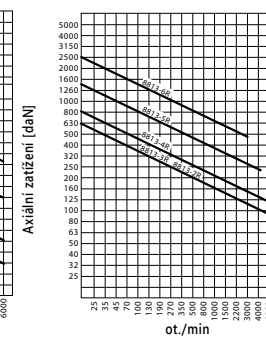

## 8813 R

- Soustružnické otočné hroty prodloužené se zmenšeným tělesem

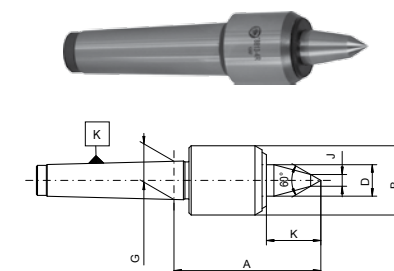

Kužel MK	Max. hmotnost obrobku [kg]	Ot./min	Házivost max.	Kód výrobku	A	B	D	G	K	J
2	170	7000	0,008	800006709	73	32	15	17,780	29	10
3	340	7000	0,008	800006710	74	34	15	23,825	30	11
4	700	6300	0,008	800006245	88,5	42	20	31,267	38	13
5	1400	4300	0,01	800006711	119	58	30	44,399	49	14
6	3000	3000	0,02	800006712	164	80	42	63,348	70	18

## 8814 R

- Soustružnické otočné hroty prodloužené

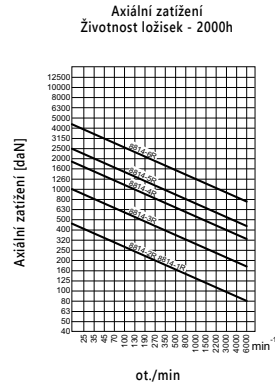
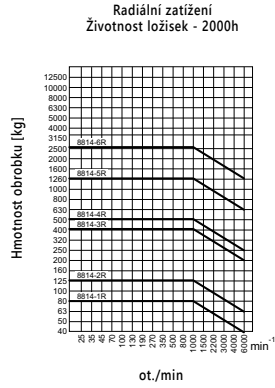
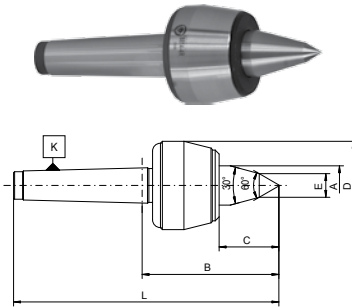

Kužel MK	Max. hmotnost obrobku [kg]	Ot./min	Házivost max.	Kód výrobku	A	B	C	D	E	L
1	80	7000	0,010	800006536	15	66,5	23,0	36	9	120,0
2	140	7000	0,005	800006537	20	74,5	33,5	45	10	138,5
3	400	5000	0,005	800006538	25	92,0	43,5	60	12	173,0
4	500	3800	0,005	800006539	32	113,5	52,0	70	14	216,0
5	1200	3000	0,005	800005509	40	144,3	65,3	90	16	272,8
6	2500	2600	0,010	800006540	50	170,5	77,5	105	18	352,5

## 8814 NC

- Soustružnické otočné hroty prodloužené pro CNC soustruhy
- Pro hydraulické koniky

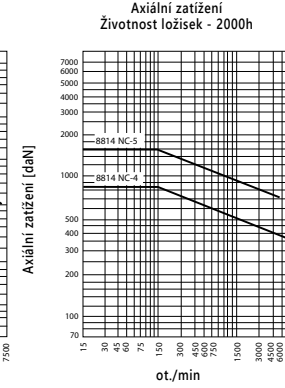
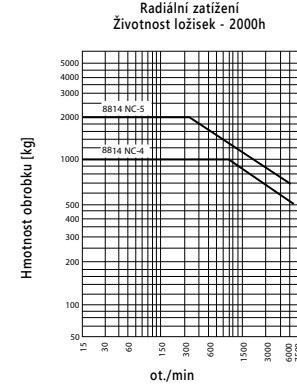
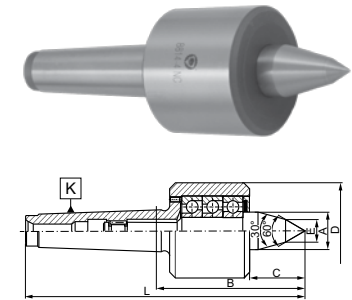

K MK	Max. hmotnost obrobku [kg]	Ot./min	Přesný Házivost max.	Přesný		Standardní		A	B	C	D	E	L
				Kód výrobku	Házivost max.	Kód výrobku	Házivost max.						
4	1000	7000	0,005	800002540	0,010	800002541	28,0	118,5	49	70	14	221,0	
5	2000	6000	0,005	800002542	0,010	800002543	40,0	150,5	67,5	95	16	280,0	

## 8815 F

- Soustružnické otočné hroty pro CNC soustruhy - se stahovací maticí

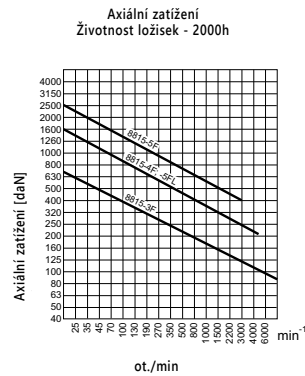
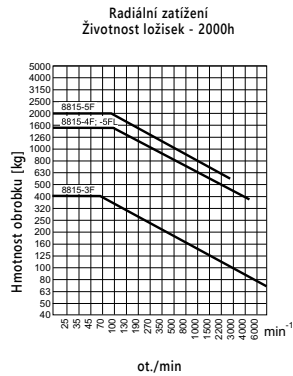
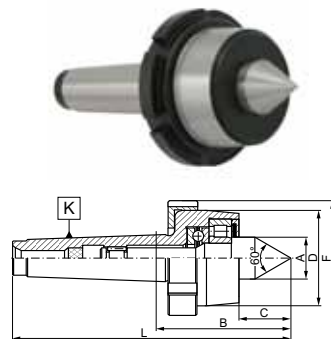

Kužel MK	Max. hmotnost obrobku [kg]	Ot./min	Házivost max.	Kód výrobku	A	B	C	D	F
3	400	6300	0,005	800002558	22	67,0	27,5	48	62
4	1600	5000	0,005	800002559	32	97,5	41,0	68	82
5L	1600	5000	0,005	Na poptávku	32	100,5	41,0	68	82
5	2000	3000	0,005	800002560	32	116,0	46,0	78	87

## 8815 NC

- Soustružnické otočné hroty prodloužené pro CNC soustruhy - se stahovací maticí
- Pro hydraulické koniky

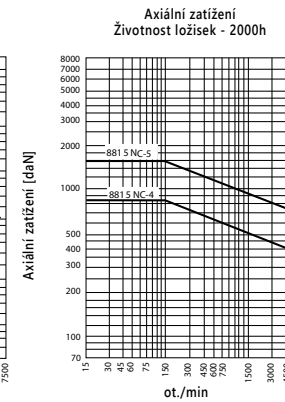
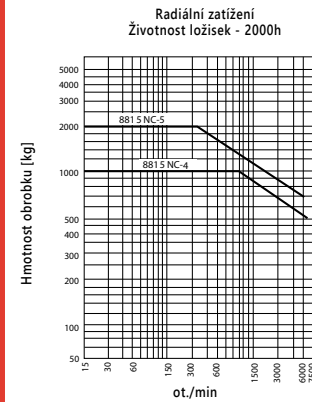
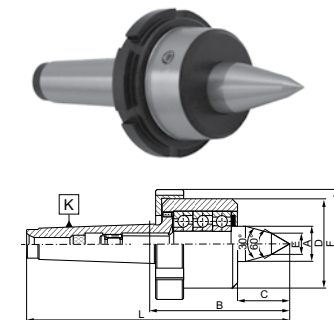

Kužel MK	Max. hmotnost obrobku [kg]	Ot./min	Házivost max.	Kód výrobku		Házivost max.		A	B	C	D	E	F	L
				přesný	standardní	přesný	standardní							
3*	500	8000	0,005	800006521	-	-	-	25	105	40,5	60	12	72	186,0
4	1000	7000	0,005	800003342	0,010	800003722	0,010	28	118,5	49,0	70	14	82	221,0
5	2000	6000	0,005	800003343	0,010	800003723	0,010	40	150,5	67,5	95	16	110	280,0

\* na poptávku

## 8823

- Soustružnické otočné hroty pro konvenční soustruhy
- S vymezením radiální házivosti

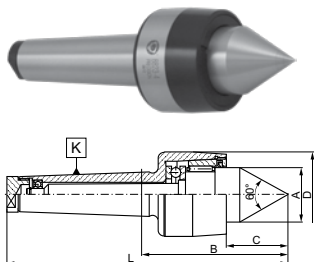

Radiální zatížení  
Životnost ložisek - 2000h

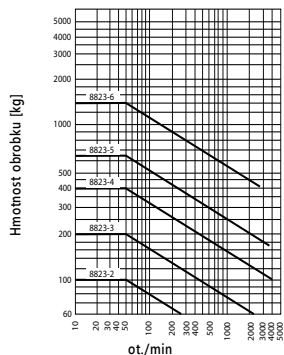

Axiální zatížení  
Životnost ložisek - 2000h

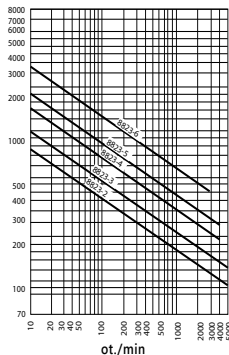

Kůžel MK	Max. hmotnost obrobku [kg]	Ot./min	Házivost max.		Kód výrobku	Házivost max.		A	B	C	D	L
			přesný	standardní		standardní	standardní					
2	100	8000	0,005	800006771	0,006	800006619	24	73,0	26,5	44	137,5	
3	200	6000	0,003	800006772	0,006	800006620	28	85,0	32,5	48	166,0	
4	400	4500	0,003	800006773	0,006	800006621	38	94,5	43,5	60	196,5	
5	650	4000	0,003	800006774	0,006	800006622	50	116,5	55,5	75	246,0	
6	1400	3000	0,003	800006775	0,008	800006776	60,5	135,0	62,5	90	317,0	

## 8809

- Soustružnické otočné hroty vnitřní pro těžké práce

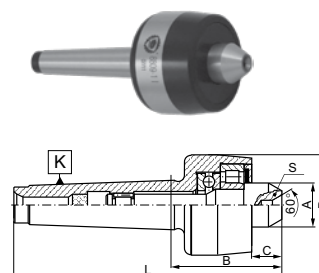

Radiální zatížení  
Životnost ložisek - 2000h

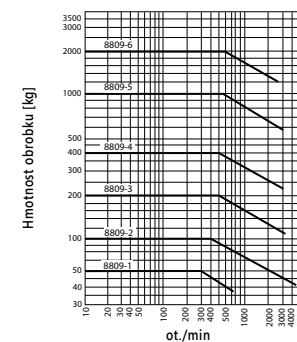

Axiální zatížení  
Životnost ložisek - 2000h

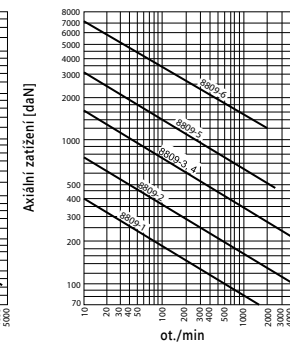

Kůžel MK	Max. hmotnost obrobku [kg]	Ot./min	Házivost max.		Kód výrobku	Házivost max.		A	B	C	D	L	E	F
			přesný	standardní		standardní	standardní							
1	50	5000	0,005	800002890	0,008	800002891	15	44,0	11,5	38	97,5	2,5	4,2	
2	100	5000	0,003	800002892	0,008	800002893	18	51,0	16,0	40	115	2,5	5,3	
3	200	4000	0,003	800002894	0,008	800002895	25	66,0	18,5	56	147	4,0	8,5	
4	400	3000	0,003	800002896	0,008	800002897	32	71,0	19,5	64	173	6,3	13,2	
5	1000	2500	0,005	800002898	0,010	800002899	40	94,5	31,0	85	224	6,3	13,2	
6	2000	2000	0,005	800002900	0,010	800002901	62,4	131,0	44,0	130	313	10,0	21,2	

## 8824

- Soustružnické otočné hroty prodloužené pro konvenční soustruhy
- S vymezením radiální házivosti

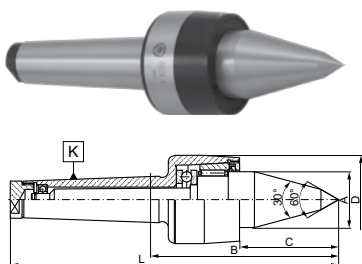

Radiální zatížení  
Životnost ložisek - 2000h

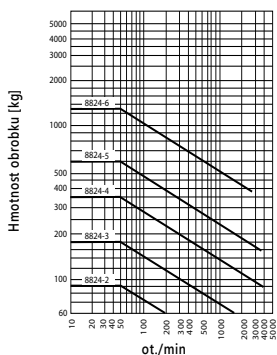

Axiální zatížení  
Životnost ložisek - 2000h

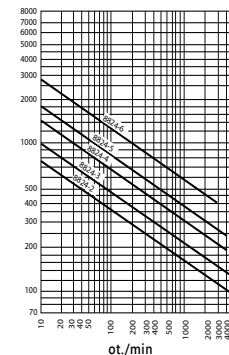

Kůžel MK	Max. hmotnost obrobku [kg]	Ot./min	Házivost max.	Kód výrobku	A	B	C	D	L
2	90	8000	0,015	800002588	24	85,0	38,5	44	149,5
3	180	6000	0,015	800002589	28	100,0	47,5	48	181,0
4	350	4500	0,015	800002590	38	117,5	66,5	60	219,5
5	600	4000	0,015	800002591	50	147,5	86,5	75	277,0
6	1300	3000	0,015	800002592	60,5	167,0	94,5	90	349,0

## 8810

- Soustružnické otočné hroty se špičkou ze slinutých karbidů pro těžké práce

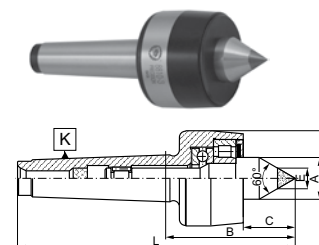

Radiální zatížení  
Životnost ložisek - 2000h

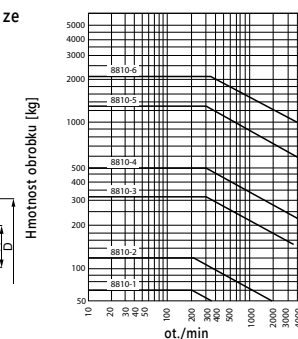

Axiální zatížení  
Životnost ložisek - 2000h

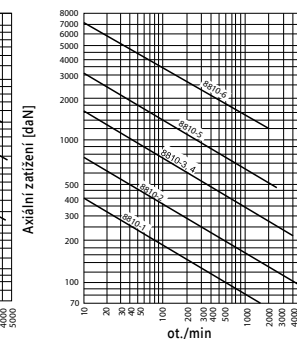

Kůžel MK	Max. hmotnost obrobku [kg]	Ot./min	Házivost max.		Kód výrobku	Házivost max.		A	B	C	D	E	L
			přesný	standardní		standardní	standardní						
1	60	5000	0,005	800002477	0,008	800002478	15	49,5	17,0	38	7	103,0	
2	120	5000	0,003	800002479	0,008	800002480	18	56,5	21,5	40	7	120,5	
3	320	4000	0,003	800002481	0,008	800002482	25	75,0	27,5	56	11	156,0	
4	500	3000	0,003	800002483	0,008	800002484	32	85,0	33,5	64	14	187,0	
5	1250	2500	0,005	800002485	0,010	800002486	40	108,0	44,0	85	18	237,0	
6	2200	2000	0,005	800002487	0,010	800002488	62,4	151,5	64,0	130	18	333,5	

\* Použití otočného hrotu pro těžké práce s lehčím obrobkem / nebo menší axiální silou než je specifikováno může mít za následek větší házivost hrotu.

1  
2  
3  
4  
5  
6  
7



Radiální zatížení  
Životnost ložisek - 2000h

 Axialní zatížení  
Životnost ložisek - 2000h

## 8811

■ Soustružnické otočné hroty pro těžké práce

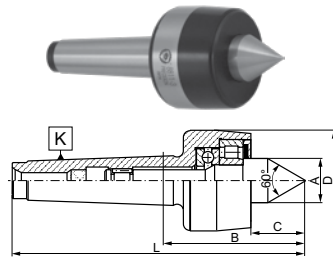
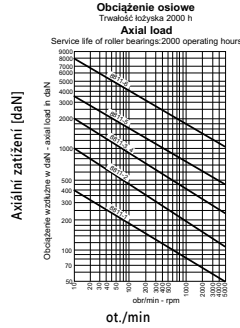
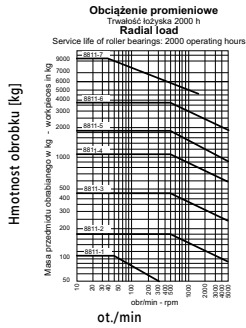

Kužel MK	Max. hmotnost obrobku [kg]	Ot./min	Házivost max.		Kód výrobku	Házivost max.	Kód výrobku	A	B	C	D	L
			presný	standardní								
1	100	5000	0,005		800006827	0,008	800006834	15	49,5	17,0	38	103,0
2	180	5000	0,003		800006828	0,008	800006835	18	56,5	21,5	40	120,5
3	450	4000	0,003		800006829	0,008	800006836	25	75,0	27,5	56	156,0
4	1000	3000	0,003		800006830	0,008	800006837	32	85,0	33,5	64	187,0
5	1900	2500	0,005		800006831	0,010	800006838	40	108,0	44,0	85	237,0
6	3700	2000	0,005		800006832	0,010	800006839	62,4	151,5	64,0	130	333,5
7	9500	1000	0,012		800006833	0,020	800006840	75	196,5	73,5	150	447,0

 Radiální zatížení  
Životnost ložisek - 2000h

 Axialní zatížení  
Životnost ložisek - 2000h

## 8815

■ Soustružnické otočné hroty se stahovací maticí pro těžké práce

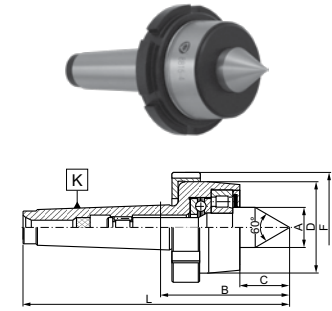
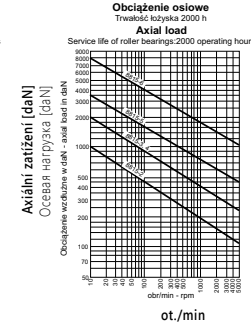
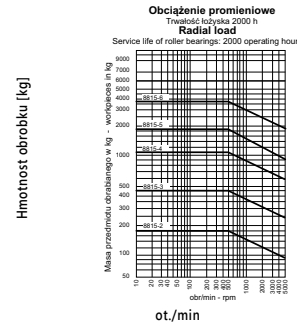

Kužel MK	Max. hmotnost obrobku [kg]	Ot./min	Házivost max.		Kód výrobku	Házivost max.	Kód výrobku	A	B	C	D	F	L
			presný	standardní									
1	100	5000	0,005		800006851	0,008	800006857	15	49,5	17,0	38	50	103,0
2	180	5000	0,003		800006852	0,008	800006858	18	56,5	21,5	40	52	120,5
3	450	4000	0,003		800006853	0,008	800006859	25	75,0	27,5	56	68	156,0
4	1000	3000	0,003		800006854	0,008	800006860	32	85,0	33,5	64	76	187,0
5	1900	2500	0,005		800006855	0,010	800006861	40	108,0	44,0	85	100	237,0
6	3700	2000	0,005		800006856	0,010	800006862	62,4	151,5	64,0	130	150	333,5

 Radiální zatížení  
Životnost ložisek - 2000h

 Axialní zatížení  
Životnost ložisek - 2000h

## 8814

■ Soustružnické otočné hroty prodloužené pro těžké práce

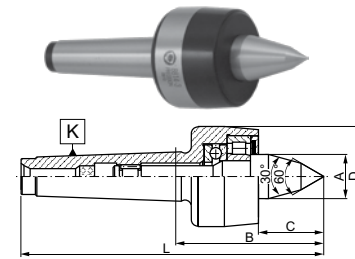
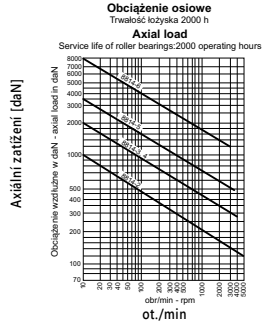
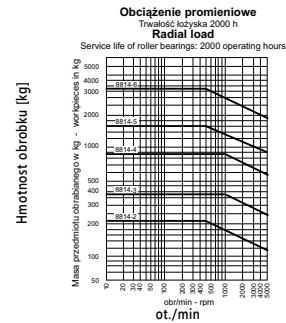

Kužel MK	Max. hmotnost obrobku [kg]	Ot./min	Házivost max.		Kód výrobku	Házivost max.	Kód výrobku	A	B	C	D	L
			presný	standardní								
2	230	5000	0,008		800006841	0,015	800006846	18,0	64,5	29,5	40	128,5
3	380	4000	0,008		800006842	0,015	800006847	25,0	88,0	40,5	56	169,0
4	850	3000	0,008		800006843	0,015	800006848	32,0	103,0	51,5	64	205,0
5	1600	2500	0,010		800006844	0,020	800006849	40,0	130,0	66,0	85	259,0
6	3150	2000	0,010		800006845	0,020	800006850	62,4	178,0	92,0	130	360,5

 Radiální zatížení  
Životnost ložisek - 2000h

 Axialní zatížení  
Životnost ložisek - 2000h

## 8816

■ Soustružnické otočné hroty se stahovací maticí a špičkou ze slinutých karbidů pro těžké práce

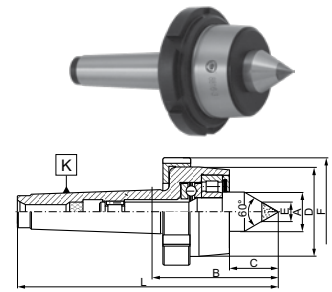
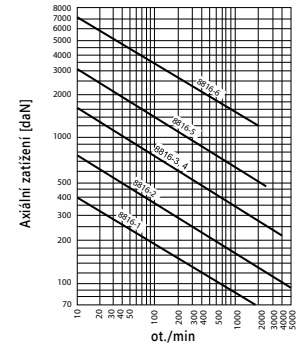
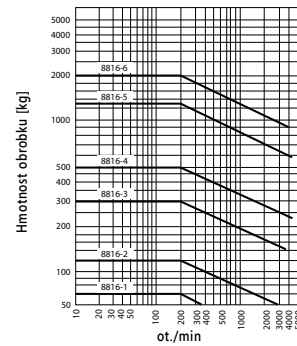

Kužel MK	Max. hmotnost obrobku [kg]	Ot./min	Házivost max.		Kód výrobku	Házivost max.	Kód výrobku	A	B	C	D	E	L
			presný	standardní									
1	60	5000	0,005		800002561	0,008	800002562	15	49,5	17,0	38	7	103,0
2	120	5000	0,003		800002563	0,008	800002564	18	56,5	21,5	40	7	120,5
3	300	4000	0,003		800002565	0,008	800002566	25	75,0	27,5	56	11	156,0
4	500	3000	0,003		800002567	0,008	800002568	32	85,0	33,5	64	14	187,0
5	1250	2500	0,005		800002569	0,010	800002570	40	108,0	44,0	85	100	237,0
6	2000	2000	0,005		800002571	0,010	800002572	62,4	151,5	64,0	130	18	333,5

\* Použití otočného hrotu pro těžké práce s lehčím obrobkem / nebo menší axialní silou než je specifikováno může mít za následek větší házivost hrotu.

## 8831-KPL-SADA

■ Soustružnické otočné hroty se sadou výměných koncovek

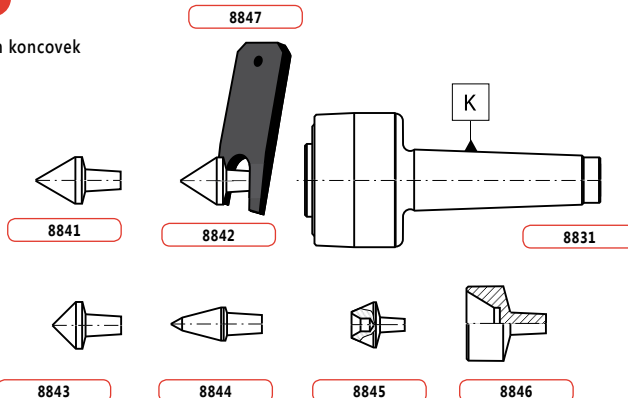

Kožel MK	Max. hmotnost obrobku [kg]	Ot./min	Házivost max.		Kód výrobku
			přesný	standardní	
2	70	5000	0,010	0,020	800002610
3	120	4000	0,010	0,020	800002612
4	280	3000	0,010	0,020	800002614
5	650	2500	0,015	0,030	800002616
6	1200	2000	0,015	0,030	800002618

## 8831

■ Soustružnické otočné hroty pro výměnitelné koncovky - tělesa

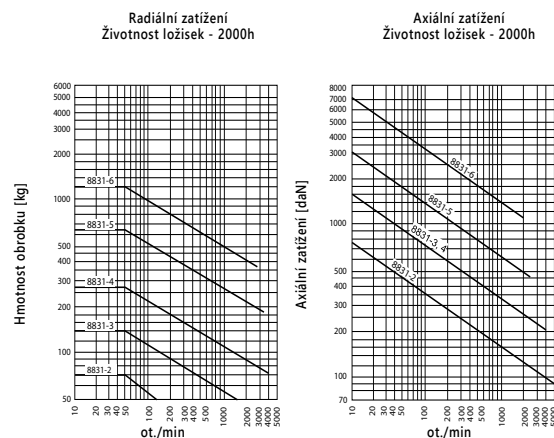
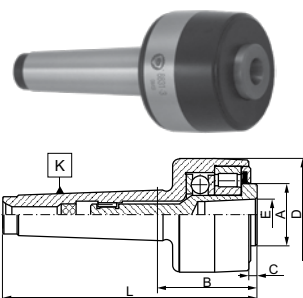

Kožel MK	Házivost max.		Kód výrobku	Házivost max.		Kód výrobku	A	B	C	D	L	E
	přesný	standardní		přesný	standardní							
2	0,010	0,020	800002620	0,020	0,030	800002621	18	39	4,0	40	103,0	7
3	0,010	0,020	800002622	0,020	0,030	800002623	25	52	4,5	56	133,0	12
4	0,010	0,020	800002624	0,020	0,030	800002625	32	57	5,5	64	159,0	15
5	0,015	0,030	800002626	0,030	0,040	800002627	40	70	6,0	85	199,0	22
6	0,015	0,030	800002628	0,030	0,040	800002629	62,4	94	6,5	130	276,0	28

## 8841

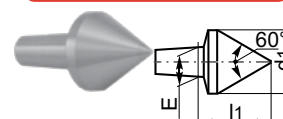

Kód výrobku	W*	d <sub>1</sub>	E	l <sub>1</sub>
800002660	2	18	7	21,0
800002661	3	25	12	28,0
800002662	4	28	15	30,5
800002663	5	40	22	42,5
800002664	6	60	28	61,5

\*Velikost

## 8842

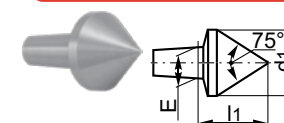

Kód výrobku	W*	d <sub>1</sub>	E	l <sub>1</sub>
800002665	2	18	7	17,5
800002666	3	25	12	23,0
800002667	4	28	15	25,0
800002668	5	40	22	34,0
800002669	6	60	28	50,5

\*Velikost

## 8843

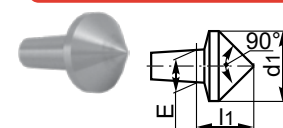

Kód výrobku	W*	d <sub>1</sub>	E	l <sub>1</sub>
800002670	2	18	7	15,0
800002671	3	25	12	19,0
800002672	4	28	15	21,0
800002673	5	40	22	28,0
800002674	6	60	28	40,0

\*Velikost

## 8847

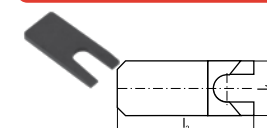

Kód výrobku	W*	l <sub>1</sub>	l <sub>2</sub>
800002909	2	20	50
800002910	3	30	70
800002911	4	45	100
800002912	5	55	120
800002913	6	65	160

\*Velikost

## 8844

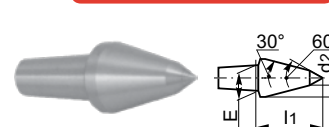

Kód výrobku	W*	d <sub>1</sub>	d <sub>2</sub>	E	l <sub>1</sub>
800002675	2	15	6	7	27,0
800002676	3	18	8	12	31,0
800002677	4	25	12	15	40,5
800002678	5	28	13	22	45,5
800002679	6	40	18	28	63,5

\*Velikost

## 8845

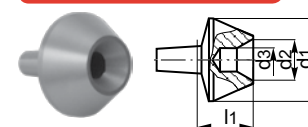

Kód výrobku	W*	d <sub>1</sub>	d <sub>2</sub>	d <sub>3</sub>	E	l <sub>1</sub>
800002680	2	28	12	6	7	18,5
800002681	3	40	19	10	12	24,0
800002682	4	55	22	10	15	36,5
800002683	5	70	32	10	22	42,0
800002684	6	100	50	15	28	56,0

\*Velikost

## 8846

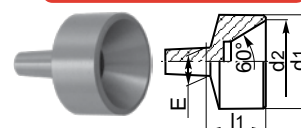

Kód výrobku	W*	d <sub>1</sub>	d <sub>2</sub>	E	l <sub>1</sub>
800002904	2	28	24	7	21,5
800002905	3	40	35	12	26,5
800002906	4	55	48	15	39,0
800002907	5	70	63	22	47,0
800002908	6	100	90	28	62,0

\*Velikost

1  
2  
3  
4  
5  
6  
7

**8848**

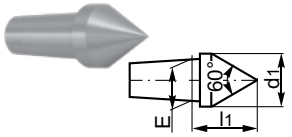

Kód výrobku	W*	d <sub>1</sub>	E	l <sub>1</sub>
800002914	2	15	10	19
800002915	3	20	15	25
800002916	4	25	20	30
800002917	5	32	25	35
800002918	6	36	30	44

\*Velikost

**8849**

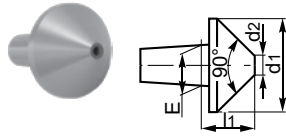

Kód výrobku	W*	d <sub>1</sub>	d <sub>2</sub>	E	l <sub>1</sub>
800002919	2	22	3	10	15
800002920	3	36	6	15	22
800002921	4	45	10	20	25
800002922	5	56	14	25	30
800002923	6	70	18	30	36

\*Velikost

**8850**

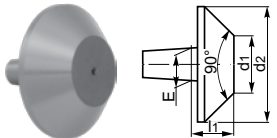

Kód výrobku	W*	d <sub>1</sub>	d <sub>2</sub>	E	l <sub>1</sub>
800002924	2	37	18	10	15
800002925	3	63	33	15	22
800002926	4	70	35	20	25
800002927	5	80	38	25	30
800002928	6	100	50	30	36

\*Velikost

**8851**

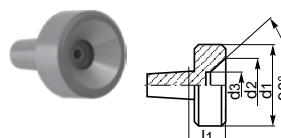

Kód výrobku	W*	d <sub>1</sub>	d <sub>2</sub>	d <sub>3</sub>	E	l <sub>1</sub>
800002929	2	22	18	8	10	15
800002930	3	36	28	12	15	22
800002931	4	45	37	17	20	25
800002932	5	56	44	20	25	30
800002933	6	70	58	24	30	36

\*Velikost

**8852**

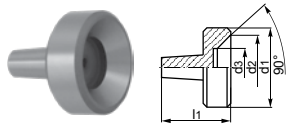

Kód výrobku	W*	d <sub>1</sub>	d <sub>2</sub>	d <sub>3</sub>	E	l <sub>1</sub>
800002934	2	30	25	15	10	15
800002935	3	45	38	22	15	22
800002936	4	63	53	30	20	25
800002937	5	70	60	36	25	30
800002938	6	100	88	54	30	36

\*Velikost

**8853**

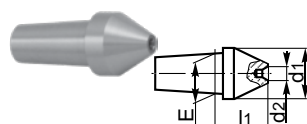

Kód výrobku	W*	d <sub>1</sub>	d <sub>2</sub>	E	l <sub>1</sub>
800002939	2	15	1,25	10	15
800002940	3	20	1,25	15	22
800002941	4	25	2,5	20	25
800002942	5	32	2,5	25	30
800002943	6	36	4,0	30	36

\*Velikost

**8854**

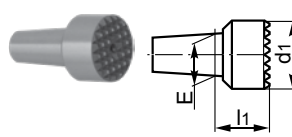

Kód výrobku	W*	d <sub>1</sub>	E	l <sub>1</sub>
800002944	2	18	10	15
800002945	3	25	15	22
800002946	4	32	20	25
800002947	5	45	25	30
800002948	6	56	30	36

\*Velikost

**8855**

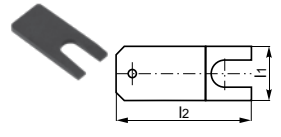

Kód výrobku	W*	l <sub>1</sub>	l <sub>2</sub>
800002949	2	20	60
800002950	3	30	80
800002951	4	40	100
800002952	5	50	120
800002953	6	60	160

\*Velikost

**8855**

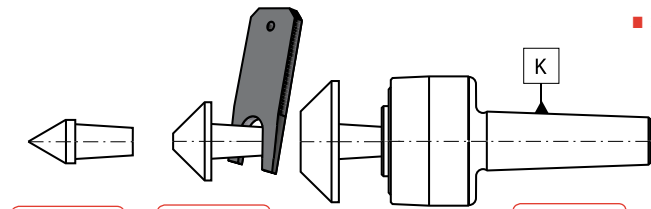

**8832-KPL-SADA**

■ Soustružnické otočné hroty se sadou výměných koncovek

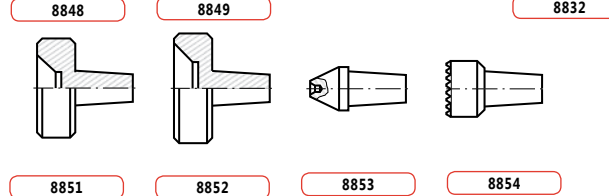

Kůžel MK	Max. hmotnost obrobku [kg]	Ot./min	Házivost max.	Kód výrobku	
				přesný	standardní
2	70	5000	0,010	800002635	800002636
3	120	4000	0,010	800002637	800002638
4	280	3000	0,010	800002639	800002640
5	650	2500	0,015	800002641	800002642
6	1200	2000	0,015	800002643	800002644

Radiální zatížení  
Životnost ložisek - 2000h

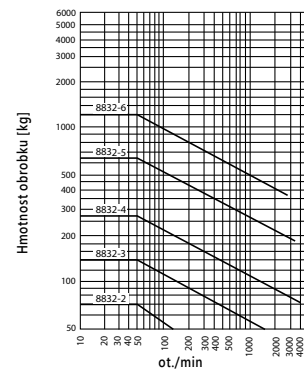

Axiální zatížení  
Životnost ložisek - 2000h

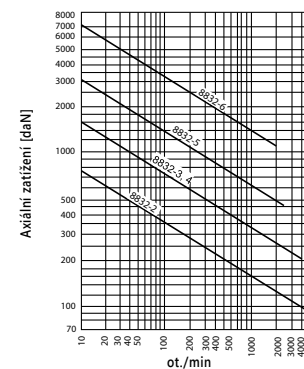

**8832**

■ Soustružnické otočné hroty pro výměnitelné koncovky - tělesa

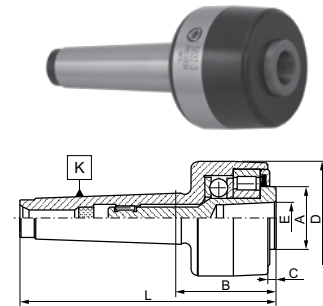

Kůžel MK	Házivost max.	Kód výrobku	Házivost max.	Kód výrobku	A	B	C	D	L	E
2	0,010	800002645	0,020	800002646	22	41	3,0	45	105,0	10
3	0,010	800002647	0,020	800002648	25	52	4,5	56	133,0	15
4	0,010	800002649	0,020	800002650	32	57	5,5	64	159,0	20
5	0,015	800002651	0,030	800002652	40	70	6,0	85	199,0	25
6	0,015	800002653	0,030	800002654	62,4	94	6,5	130	276,0	30

## 8825

■ Soustružnické otočné hroty na trubky s úhlem 60°

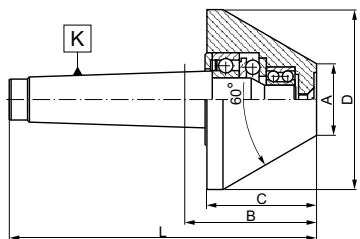

Velikost	Kužel MK	Max. hmotnost obrobku [kg]	Ot./min	Házivost max.	Kód výrobku	A	B	C	D	L
1	1	100	5000	0,008	800002598	20	40,5	35	50	94,0
2	2	180	5000	0,008	800002599	30	41,5	35	60	105,5
2-1	2	300	4500	0,008	800002600	30	59,0	53	80	123,0
3	3	350	4500	0,008	800002601	30	59,0	53	80	140,0
3-1	3	550	3000	0,008	800002602	40	67,0	61	100	148,0
3-2	3	600	3000	0,008	800002603	50	76,0	70	120	157,0
4	4	600	3000	0,008	800002604	40	68,5	61	100	171,0
4-1	4	700	3000	0,008	800002605	50	77,5	70	120	180,0
4-2	4	700	3000	0,010	800002606	70	77,5	70	140	180,0
5	5	750	3000	0,010	800002607	50	77,5	70	120	207,0
5-1	5	750	2000	0,020	800002608	100	77,5	70	170	207,0
6	6	2000	1000	0,050	800002609	180	116,0	107	292	298,0

## 8882

■ Soustružnické otočné hroty na trubky s výměnnými talíři s úhlem 75°

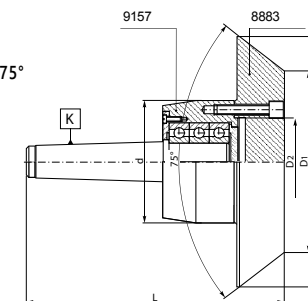
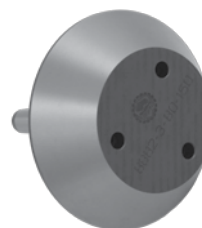

Kužel MK	d	D	D <sub>1</sub>	D <sub>2</sub>	L	Max. hmotnost obrobku [kg]	Ot./min	Házivost max.	Sestava 8882	Talíř 8883	Otočné těleso 9157
									Kód výrobku		
3	80	150	95	56	180	700	4000	0,05	800002954	800002967	800002984
3	80	200	145	56	180	700	4000	0,05	800002955	800002968	800002984
4	100	150	95	70	206	1000	3500	0,05	800002956	800002969	800002985
4	100	200	145	70	206	1000	3500	0,05	800002957	800002970	800002985
4	100	250	195	70	206	1000	3500	0,05	800002958	800002971	800002985
4	125	200	145	95	215	1500	3200	0,05	800002959	800002972	800002986
4	125	250	195	95	215	1500	3200	0,05	800002960	800002973	800002986
4	125	300	245	95	215	1500	3200	0,05	800002961	800002974	800002986
5	125	200	145	95	242	1500	3200	0,05	800002962	-	800002987
5	125	250	195	95	242	1500	3200	0,05	800002963	-	800002987
5	125	300	245	95	242	1500	3200	0,05	800002964	-	800002987
5	160	250	195	125	245	1800	3000	0,05	800002965	800002975	800002988
5	160	300	245	125	245	1800	3000	0,05	800002966	800002976	800002988

## 8410

■ Čelní unašeční hroty hydraulické  
■ Standardně osazeny unašeční pro pravé otáčky

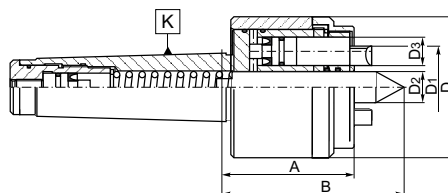

Kód výrobku	D <sub>1</sub>	Kužel MK	D	D <sub>2</sub>	D <sub>3</sub>	A	B	Házivost max.	Max. hmotnost obrobku [kg]
800002740	27	4	68	12	12	64	80	0,02	55
800002741	27	5	68	12	12	64	80	0,02	55
800002742	40	4	81	14	12	67	84	0,02	65
800002743	40	5	81	14	12	67	84	0,02	65
800002744	50	5	90	20	18	86	113	0,03	100
800002745	63	5	100	20	18	86	113	0,03	100

### NÁHRADNÍ DÍLY PRO 8410



■ Sada tří unašečů pro levé otáčky



■ Sada tří unašečů pro pravé otáčky



■ Středící hrot

Kód	Typ	Pro typ
800002748	S-2084/1	800002740
800002748	S-2084/1	800002741
800002751	S-2031/1	800002742
800002751	S-2031/1	800002743
800002754	S-2041/1	800002744
800002756	S-2243/0	800002745

Kód	Typ	Pro typ
800002747	S-2084/0	800002740
800002747	S-2084/0	800002741
800002750	S-2031/0	800002742
800002750	S-2031/0	800002743
800002753	S-2041/0	800002744
800002755	S-2242/0	800002745

Kód	Typ	Pro typ
800002746	S-2083/0	800002740
800002746	S-2083/0	800002741
800002749	S-2030/0	800002742
800002749	S-2030/0	800002743
800002752	S-2040/0	800002744
800002752	S-2240/0	800002745

1  
2  
3  
4  
5  
6  
7

## 8711

- Pevné hroty 60° se špičkou ze slinutého karbidu

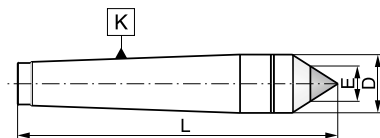

Kód výrobku	Kužel MK	L	D	E
800002824	0	70	9,2	5
800002825	1	80	12,2	7
800002826	2	100	18,0	7
800002827	3	125	24,1	11
800002828	4	160	31,6	14
800002829	5	200	44,7	18
800002830	6	270	63,8	18

## 8712

- Pevné hroty 60°
- Provedení s úhlem 90° je na poptávku

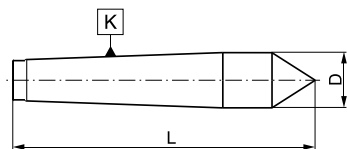

Kód výrobku	Kužel MK	L	D
800002831	0	70	9,2
800002832	1	80	12,2
800002833	2	100	18,0
800002834	3	125	24,1
800002835	4	160	31,6
800002836	5	200	44,7
800002837	6	270	63,8
800002838	7	360	83,5

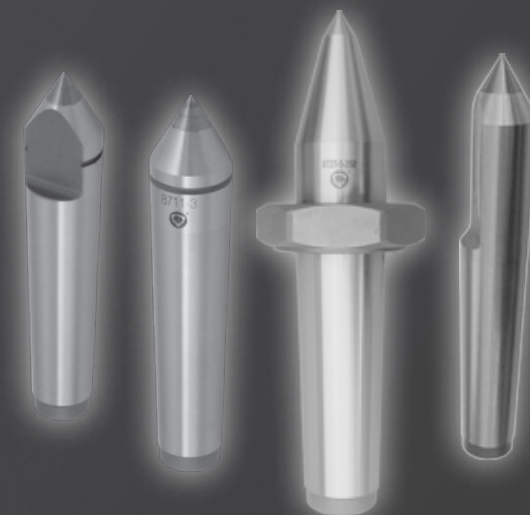

## 8720

- Pevné hroty 60° s ploškou pro klíč

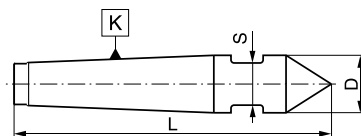

Kód výrobku	Kužel MK	L	D	S
800002839	0	78	9,2	7
800002840	1	90	12,2	10
800002841	2	112	18,0	13
800002842	3	138	24,1	19
800002843	4	175	31,6	24
800002844	5	217	44,7	36
800002845	6	290	63,8	55

## 8721

- Pevné hroty 60° s ploškou pro klíč se špičkou ze slinutého karbidu

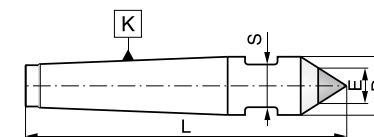

Kód výrobku	Kužel MK	L	D	E	S
800002846	0	78	9,2	5	7
800002847	1	90	12,2	7	10
800002848	2	112	18,0	7	13
800002849	3	138	24,1	11	19
800002850	4	175	31,6	14	24
800002851	5	217	44,7	18	36
800002852	6	290	63,8	18	55

## 8725

- Pevné hroty 60° se stahovací maticí

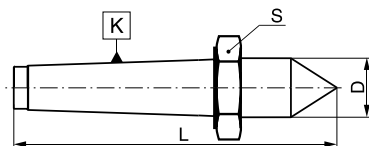

Kód výrobku	Kužel MK	L	D	S	Ø
800002853	0	78	9,2	19	S-0772/0
800002854	1	90	12,2	24	S-0774/0
800002855	2	112	18,0	32	S-0776/0
800002856	3	138	24,1	41	S-0778/0
800002857	4	175	31,6	55	S-0780/0
800002858	5	217	44,7	75	S-0782/0
800002859	6	290	63,8	100	S-0784/0

## 8726

- Pevné hroty 60° se stahovací maticí se špičkou ze slinutého karbidu

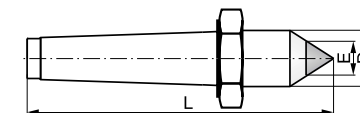

Kód výrobku	Kužel MK	L	D	E	S	Ø
800002860	0	78	9,2	5	19	S-0772/0
800002861	1	90	12,2	7	24	S-0774/0
800002862	2	112	18,0	7	32	S-0776/0
800002863	3	138	24,1	11	41	S-0778/0
800002864	4	175	31,6	14	55	S-0780/0
800002865	5	217	44,7	18	75	S-0782/0
800002866	6	290	63,8	18	100	S-0784/0

## 8727

- 60° pevné hroty s prodlouženým hrotem se stahovací maticí

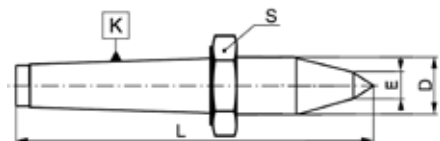

Kód výrobku	Kužel MK	L	D	E	S	Ø
800005469	2	118	18	10	32	S-0776/0
800005470	3	148	24	12	41	S-0778/0
800005471	4	186	32	14	55	S-0780/0
800005472	5	242	45	16	75	S-0782/0

## 8727 SPEC

- 60° pevné hroty s prodlouženým hrotem se stahovací maticí
- Jiné rozměry na poptávku

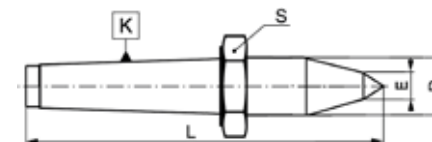

Kód výrobku	Kužel MK	L	D	E	Ø
800006004	4	200	31,6	14	S-0780/0
800006005	5	250	44,7	16	S-0782/0
800006863	6	330	63,8	20	S-0784/0

1

2

3

4

5

6

7

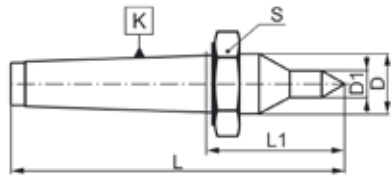

### 8728

- 60° pevné hroty s tenkým prodlouženým hrotem se stahovací maticí

Kód výrobku	Kužel MK	L	D	E	S	
800005473	2	118	18	8	32	S-0776/0
800005474	3	148	24	10	41	S-0778/0
800005475	4	186	32	12	55	S-0780/0
800005476	5	242	45	14	75	S-0782/0

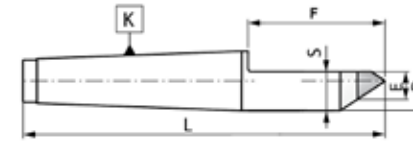

### 8731 SPEC

- Pevné hroty 60° s vybráním a špičkou ze slinutého karbidu
- Prodloužená verze se zvětšeným karbidem - speciálně navrženo pro brusky
- Dostatečná vzdálenost F pro vyjetí brousícího kotouče
- Jiné rozměry na poptávku

Kód výrobku	Kužel MK	L	D	E	F	S
800005918	3	142	24,1	14	55	19,9
800005959	4	195	31,6	18	85	25,7
Na poptávku	5	300	44,7	18	150	*

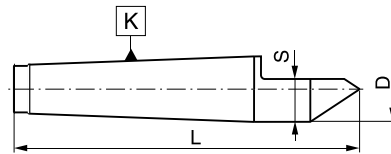

### 8730

- Pevné hroty 60° s vybráním

Kód výrobku	Kužel MK	L	D	S
800002867	0	70	9,2	5,6
800002868	1	80	12,2	7,6
800002869	2	100	18,0	11,0
800002870	3	125	24,1	15,0
800002871	4	160	31,6	20,8
800002872	5	200	44,7	29,3
800002873	6	270	63,8	42,6

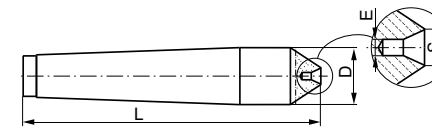

### 8735

- Pevné hroty 60° vnitřní

Kód výrobku	Kužel MK	L	D	E	S
800002881	0	66	9,2	1,0	2,12
800002882	1	74	12,2	1,6	3,35
800002883	2	94	18,0	2,5	5,30
800002884	3	115	24,1	4,0	8,50
800002885	4	146	31,6	6,3	13,20

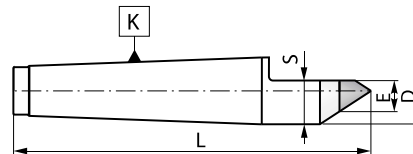

### 8731

- Pevné hroty 60° s vybráním a špičkou ze slinutého karbidu

Kód výrobku	Kužel MK	L	D	E	S
800002874	0	70	9,2	5	7,8
800002875	1	80	12,2	7	10,3
800002876	2	100	18,0	7	13,0
800002877	3	125	24,1	11	18,3
800002878	4	160	31,6	14	23,5
800002879	5	200	44,7	18	32,0
800002880	6	270	63,8	18	41,7

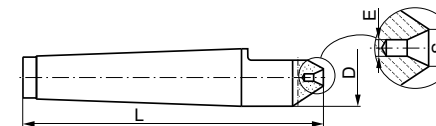

### 8740

- Pevné hroty 60° vnitřní s vybráním

Kód výrobku	Kužel MK	L	D	E	S
800002886	0	66	9,2	1,0	2,20
800002887	1	74	12,2	1,6	3,35
800002888	2	94	18,0	2,5	5,30
800002889	3	115	24,1	4,0	8,50

## DIN 69871

- Materiál: legovaná ocel chrom-manganová
- Cementováno do hloubky 0,7mm
- Kaleno a přesně broušeno
- Tvrdost povrchů 58±2 HRC
- Tolerance úhlu kuželu AT3

### Význam dodatkových písmen

- A = verze bez vnitřního chlazení
- AD = verze s přívodem chlazení středem vřetene (přes upínací čep)
- B = verze s přívodem chlazení z límce upínáče
- AD+B = kombinace AD a B

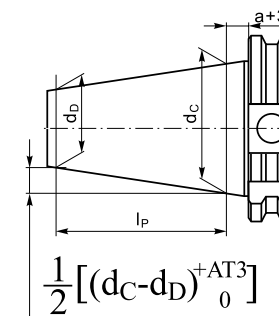
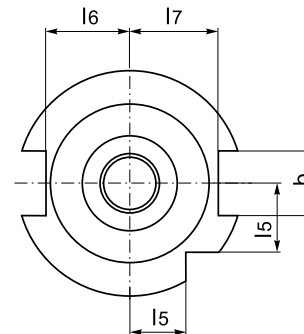
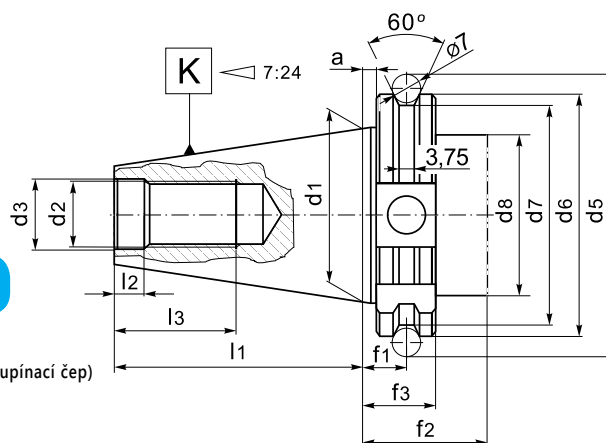

K 7:24	d <sub>c</sub> -d <sub>b</sub>	l <sub>p</sub>	a	AT3
30	12,250	42	3,2	0,002
40	17,208	59	3,2	0,003
50	26,833	92	3,2	0,004

K 7:24	a	bH12	d <sub>1</sub>	d <sub>2</sub>	d3H7	d <sub>5</sub>	d <sub>6</sub>	d <sub>7</sub>	d <sub>8</sub> max	f <sub>1</sub>	f <sub>2</sub> min	f <sub>3</sub>	l <sub>1</sub>	l <sub>2</sub>	l <sub>3</sub>	l <sub>5</sub>	l <sub>6</sub>	l <sub>7</sub>
30	3,2	16,1	31,75	M12	13	59,3	50	44,3	45	11,1	35	19,1	47,8	5,5	24	15	16,4	19
40	3,2	16,1	44,45	M16	17	72,3	63,55	56,25	50	11,1	35	19,1	68,4	8,2	32	18,5	22,8	25
50	3,2	25,7	69,85	M24	25	107,25	97,5	91,25	80	11,1	35	19,1	101,75	11,5	47	30	35,5	37,7

## 7617 AD

## 7617 AD+B

- Kleštinové upínáče pro kleštiny ER (DIN 6499)



AD

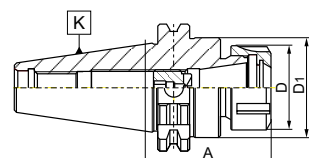

AD+B

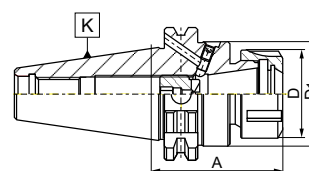

Kód výrobku	K 7:24	Kleština	A	Provedení	Rozsah upínání	D	D <sub>1</sub>		
800001784	30	ER16	60	AD	2-10	32	32	9833-16ES	M10x11LH
800004678	30	ER25	60	AD	2-16	42	32	9833-25ES	M18x1,5x19LH
na poptávku	30	ER25	100	AD	2-16	42	32	9833-25ES	M18x1,5x19LH
800001785	30	ER32	60	AD	2-20	50	37	9833-32ES	M18x1,5x19LH
800003335	40	ER16	60	AD	2-10	32	45	9833-16ES	M12x1,5x14LH
800001794	40	ER16	60	AD+B	2-10	32	50	9833-16ES	M12x1,5x14LH
800001786	40	ER25	60	AD	2-16	42	45	9833-25ES	M18x1,5x19LH
800001795	40	ER25	60	AD+B	2-16	42	50	9833-25ES	M18x1,5x19LH
800006760	40	ER25	100	AD	2-16	42	45	9833-25ES	M18x1,5x19LH
800006564	40	ER25	130	AD	2-16	42	45	9833-25ES	M18x1,5x19LH
800006781	40	ER25	160	AD+B	2-16	42	50	9833-25ES	M18x1,5x19LH
800001787	40	ER32	70	AD	2-20	50	45	9833-32ES	M22x1,5x24LH
800001796	40	ER32	70	AD+B	2-20	50	50	9833-32ES	M22x1,5x24LH
800006782	40	ER32	100	AD	2-20	50	45	9833-32ES	M22x1,5x24LH
800001788	40	ER32	130	AD	2-20	50	45	9833-32ES	M22x1,5x24LH
800001797	40	ER32	160	AD+B	2-20	50	50	9833-32ES	M22x1,5x24LH
800001789	40	ER40	70	AD	2-26	63	45	9833-40ES	M28x1,5x30LH
800001798	40	ER40	70	AD+B	2-26	63	50	9833-40ES	M28x1,5x30LH

Kód výrobku	K 7:24	Kleština	A	Provedení	Rozsah upínání	D	D <sub>1</sub>		
800001790	50	ER32	70	AD	2-20	50	70	9833-32ES	M22x1,5x24LH
800001799	50	ER32	70	AD+B	2-20	50	80	9833-32ES	M22x1,5x24LH
800001791	50	ER32	130	AD	2-20	50	70	9833-32ES	M22x1,5x24LH
800001800	50	ER32	160	AD+B	2-20	50	80	9833-32ES	M22x1,5x24LH
800001792	50	ER40	80	AD	2-26	63	70	9833-40ES	M28x1,5x30LH
800001801	50	ER40	80	AD+B	2-26	63	80	9833-40ES	M28x1,5x30LH
800001793	50	ER40	130	AD	2-26	63	70	9833-40ES	M28x1,5x30LH
800001802	50	ER40	160	AD+B	2-26	63	80	9833-40ES	M28x1,5x30LH

### Jiné rozměry jsou dostupné na poptávku

Například:

- 40-ER11Mini, 40-ER16Mini, 40-ER25Mini (v délkách A=100, 150, 200)
- 40-ER16 (A=200)
- 40-ER20 (A=70,100,120,150)
- 40-ER25-200
- 40-ER32-200
- 40-ER40 (A=100, 130, 150, 200)
- a další!



**7617-S AD**

**7617-S AD+B**

■ Kleštinové upínače pro kleštiny ER (DIN 6499) prodloužené



**AD**

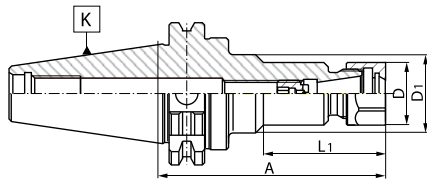

**AD+B**

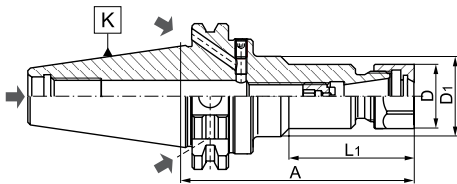

Kód výrobku	K 7:24	Kleština	A	Provedení	Rozsah upínání	L <sub>1</sub>	D	D <sub>1</sub>		
800001803	40	ER16	100	AD	2-10	-	28	-	9833-16D	M12x1,5x14LH
800001807	40	ER16	100	AD+B	2-10	-	28	-	9833-16D	M12x1,5x14LH
800001804	40	ER16	150	AD	2-10	85	28	40	9833-16D	M12x1,5x14LH
800001808	40	ER16	160	AD+B	2-10	86	28	40	9833-16D	M12x1,5x14LH
800001805	50	ER16	100	AD	2-10	-	28	-	9833-16D	M12x1,5x14LH
800001809	50	ER16	100	AD+B	2-10	-	28	-	9833-16D	M12x1,5x14LH
800001806	50	ER16	150	AD	2-10	85	28	40	9833-16D	M12x1,5x14LH
800001810	50	ER16	160	AD+B	2-10	86	28	40	9833-16D	M12x1,5x14LH

**7617-KPL**

**7617-PL**

**7617-S PL**

■ Kleštinové upínače pro kleštiny ER (DIN 6499) se sadou kleštin



Kód výrobku	K 7:24	Kleštiny	A	Rozsah upínání	Počet kleštin v sadě
<b>7617-KPL</b>					
800001811	30	ER16	60	2-10	8
800001812	30	ER32	60	2-20	18
800001813	40	ER25	60	2-16	14
800001814	40	ER32	70	2-20	18
800001815	40	ER32	130	2-20	18
800001816	40	ER40	70	2-26	24
800001817	50	ER32	70	2-20	18
800001818	50	ER32	130	2-20	18
800001819	50	ER40	80	2-26	24
800001820	50	ER40	130	2-26	24
<b>7617-PL</b>					
800001825	30	ER32	60	3-20	8
Kleštiny Ø 4,5,6,8,10,12,16,20					
800001826	40	ER32	70	3-20	8
800001827	50	ER32	70	3-20	8
Kleštiny Ø 4,5,6,8,10,12,16,20					
<b>7617-S PL</b>					
800001821	40	ER16	100	2-10	8
800001822	40	ER16	150	2-10	8
800001823	50	ER16	100	2-10	8
800001824	50	ER16	150	2-10	8

**7628 AD**

■ Frézařské trny pro nástroje s válčovou stopkou dle DIN 1835-E (Whistle-Notch)

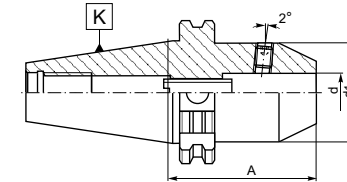

OBR.1

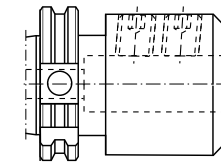

OBR.2

Kód výrobku	K 7:24	d	d <sub>1</sub>	A	Obr.		
800002359	40	6	25	50	1	U-4131/0	U-1599/0
800002360	40	8	28	50	1	U-4132/0	U-6317/0
800002361	40	10	35	50	1	U-4133/0	U-0293/0
800002362	40	12	42	50	1	U-4134/0	U-0757/0
800002363	40	14	44	63	1	U-4135/0	U-6318/0
800002364	40	16	44	63	1	U-5887/0	U-6318/0
800002365	40	18	44	63	1	U-5888/0	U-6793/0
800002366	40	20	44	63	1	U-5888/0	U-6793/0
800002367	40	25	65	100	2	2x U-4137/0	U-6794/0
800002368	40	32	72	100	2	2x U-4138/0	U-6794/0
800002348	50	6	25	63	1	U-4131/0	U-1599/0
800002349	50	8	28	63	1	U-4132/0	U-6317/0
800002350	50	10	35	63	1	U-4133/0	U-0293/0
800002351	50	12	42	63	1	U-4134/0	U-0757/0
800002352	50	14	44	63	1	U-4135/0	U-6318/0
800002353	50	16	48	63	1	U-4135/0	U-6318/0
800002354	50	18	50	63	1	U-4136/0	U-6793/0
800002355	50	20	52	63	1	U-4136/0	U-6793/0
800002356	50	25	70	80	2	2x U-4137/0	U-6794/0
800002357	50	32	72	100	2	2x U-4138/0	U-6794/0
800002358	50	40	90	120	2	2x U-5870/0	U-6794/0

## 7625 AD

■ Frézažské trny pro nástroje s válcovou stopkou dle DIN 1835-B (WELDON)

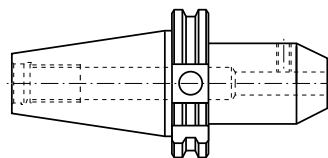

OBR. 1

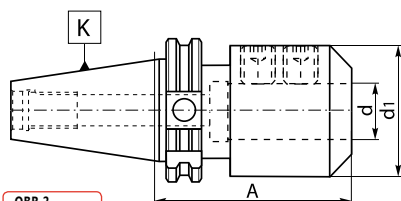

OBR. 2

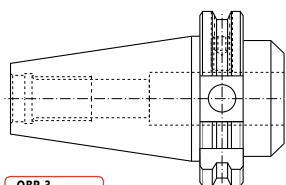

OBR. 3

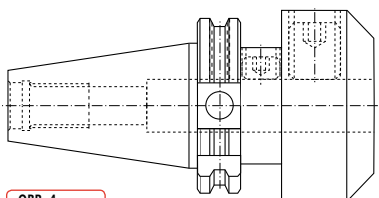

OBR. 4

Kód výrobku	K 7:24	d	A	d1	Obr.	
800002140	30	6	50	25,0	1	U-4131/0
800002141	30	8	50	28,0	1	U-4132/0
800002142	30	10	50	35,0	1	U-4133/0
800002143	30	12	50	42,0	1	U-4134/0
800002144	30	16	63	44,0	1	U-4135/0
800002145	30	20	63	44,0	1	U-5888/0
800002146	40	6	30	25,0	3	U-4131/0
800002147	40	6	50	25,0	1	U-4131/0
800002148	40	6	100	25,0	1	U-4131/0
800002149	40	6	130	25,0	1	U-4131/0
800002150	40	8	30	28,0	3	U-4132/0
800002151	40	8	50	28,0	1	U-4132/0
800002152	40	8	100	28,0	1	U-4132/0
800002153	40	8	130	28,0	1	U-4132/0
800002154	40	10	32	35,0	3	U-4133/0
800002155	40	10	50	35,0	1	U-4133/0
800002156	40	10	100	35,0	1	U-4133/0
800002157	40	10	130	35,0	1	U-4133/0
800002158	40	12	34	42,0	3	U-4134/0
800002159	40	12	50	42,0	1	U-4134/0
800002160	40	12	100	42,0	1	U-4134/0
800002161	40	12	130	42,0	1	U-4134/0
800002162	40	14	34	44,0	3	U-4134/0
800002163	40	14	50	44,0	1	U-4134/0
800002164	40	14	63	44,0	1	U-4134/0
800002165	40	16	35	44,0	3	U-4135/0
800002166	40	16	63	44,5	1	U-4135/0
800004848	40	16	100	48,0	1	U-4135/0
800002167	40	18	63	44,5	1	U-5887/0
800002168	40	20	35	44,5	3	U-6756/0
800002169	40	20	63	44,5	1	U-5888/0
800004849	40	20	100	52,0	1	U-4136/0
800006826	40	25	35	44,5	3	U-6756/0
800002170	40	25	60	44,5	4	U-6756/0+U-6757/0
800002171	40	25	100	63,0	2	2x U-4137/0
800002172	40	32	70	72,0	4	U-6755/0 + U-4138/0
800002173	40	32	100	72,0	2	2x U-4138/0
800002174	50	6	63	25,0	1	U-4131/0
800002175	50	6	130	25,0	1	U-4131/0
800002176	50	8	63	28,0	1	U-4132/0
800002177	50	8	130	28,0	1	U-4132/0
800002178	50	10	63	35,0	1	U-4133/0
800002179	50	10	130	35,0	1	U-4133/0
800002180	50	12	63	42,0	1	U-4134/0
800002181	50	12	130	42,0	1	U-4134/0
800002182	50	14	63	44,0	1	U-4134/0
800002183	50	16	63	48,0	1	U-4135/0
800002184	50	16	100	48,0	1	U-4135/0
800002185	50	16	130	48,0	1	U-4135/0
800002186	50	18	63	50,0	1	U-4135/0
800002187	50	20	35	52,0	1	U-4136/0
800002188	50	20	63	52,0	1	U-4136/0
800002189	50	20	130	52,0	1	U-4136/0
800002190	50	25	60	69,9	2	2x U-4137/0
800002191	50	25	80	65,0	2	2x U-4137/0
800002192	50	25	130	65,0	2	2x U-4137/0
800002193	50	32	70	69,9	2	2x U-4138/0
800002194	50	32	100	72,0	2	2x U-4138/0
800002195	50	32	130	72,0	2	2x U-4138/0
800002196	50	32	160	72,0	2	2x U-4138/0
800002197	50	40	100	80,0	2	2x U-5870/0
800002198	50	40	120	90,0	2	2x U-5870/0
800002199	50	50	130	100,0	2	2x U-4139/0

## 7625 AD+B

■ Frézažské trny pro nástroje s válcovou stopkou dle DIN 1835-B (WELDON)

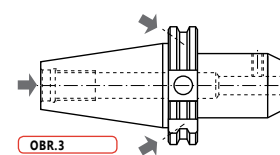

OBR. 3

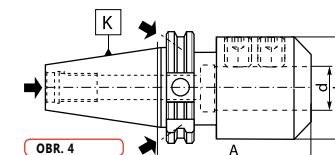

OBR. 4

Kód výrobku	K 7:24	d	A	d1	Obr.	
800002200	40	6	50	25,0	3	U-4131/0
800002201	40	6	100	25,0	3	U-4131/0
800002202	40	6	130	25,0	3	U-4131/0
800002203	40	6	160	25,0	3	U-4131/0
800002204	40	6	200	25,0	3	U-4131/0
800002205	40	8	50	28,0	3	U-4132/0
800002206	40	8	100	28,0	3	U-4132/0
800002207	40	8	130	28,0	3	U-4132/0
800002208	40	8	160	28,0	3	U-4132/0
800002209	40	8	200	28,0	3	U-4132/0
800002210	40	10	60	35,0	3	U-4133/0
800002211	40	10	100	35,0	3	U-4133/0
800002212	40	10	130	35,0	3	U-4133/0
800002213	40	10	160	35,0	3	U-4133/0
800002214	40	10	200	35,0	3	U-4133/0
800002216	40	12	60	42,0	3	U-4134/0
800002217	40	12	100	42,0	3	U-4134/0
800002218	40	12	130	42,0	3	U-4134/0
800002219	40	12	160	42,0	3	U-4134/0
800002220	40	12	200	42,0	3	U-4134/0
800002221	40	14	60	44,0	3	U-4134/0
800002221	40	14	100	44,0	3	U-4134/0
800002222	40	14	130	44,0	3	U-4134/0
800002223	40	14	160	44,0	3	U-4134/0
800002224	40	14	200	44,0	3	U-4134/0
800002225	40	16	63	44,5	3	U-4135/0
800002226	40	16	100	48,0	3	U-4135/0
800002227	40	16	130	48,0	3	U-4135/0
800002228	40	16	160	48,0	3	U-4135/0
800002229	40	16	200	48,0	3	U-4135/0
800002230	40	18	63	49,5	3	U-4135/0
800002231	40	18	100	49,5	3	U-4135/0
800002232	40	18	130	49,5	3	U-4135/0
800002233	40	18	160	49,5	3	U-4135/0
800002234	40	18	200	49,5	3	U-4135/0
800002235	40	20	63	49,5	3	U-4136/0
800002236	40	20	100	49,5	3	U-4136/0
800002237	40	20	130	49,5	3	U-4136/0
800002238	40	20	160	49,5	3	U-4136/0
800002239	40	20	200	49,5	3	U-4136/0

1

2

3

4

5

6

7

Kód výrobku	K 7:24	d	A	d1	Obr.	
800002240	40	25	100	63,0	4	2x U-4137/0
800002241	40	25	130	65,0	4	2x U-4137/0
800002242	40	25	160	65,0	4	2x U-4137/0
800002243	40	25	200	65,0	4	2x U-4137/0
800002244	40	32	100	72,0	4	2x U-4138/0
800002245	40	32	130	72,0	4	2x U-4138/0
800002246	40	32	160	72,0	4	2x U-4138/0
800002247	40	32	200	72,0	4	2x U-4138/0
800003928	40	40	120	90,0	4	2x U-5870/0
800002248	50	6	63	25,0	3	U-4131/0
800002249	50	6	100	25,0	3	U-4131/0
800002250	50	6	130	25,0	3	U-4131/0
800002251	50	6	160	25,0	3	U-4131/0
800002252	50	6	200	25,0	3	U-4131/0
800002253	50	8	63	28,0	3	U-4132/0
800002254	50	8	100	28,0	3	U-4132/0
800002255	50	8	130	28,0	3	U-4132/0
800002256	50	8	160	28,0	3	U-4132/0
800002257	50	8	200	28,0	3	U-4132/0
800002258	50	10	63	35,3	3	U-4133/0
800002259	50	10	100	35,0	3	U-4133/0
800002260	50	10	130	35,0	3	U-4133/0
800002261	50	10	160	35,0	3	U-4133/0
800002262	50	10	200	35,0	3	U-4133/0
800002263	50	12	63	42,0	3	U-4134/0
800002264	50	12	100	42,0	3	U-4134/0
800002265	50	12	130	42,0	3	U-4134/0
800002266	50	12	160	42,0	3	U-4134/0
800002267	50	12	200	42,0	3	U-4134/0
800002268	50	14	63	44,0	3	U-4134/0
800002269	50	14	100	44,0	3	U-4134/0
800002270	50	14	130	44,0	3	U-4134/0
800002271	50	14	160	44,0	3	U-4134/0
800002272	50	14	200	44,0	3	U-4134/0
800002273	50	16	63	48,0	3	U-4135/0
800002274	50	16	100	48,0	3	U-4135/0
800002275	50	16	130	48,0	3	U-4135/0
800002276	50	16	160	48,0	3	U-4135/0
800002277	50	16	200	48,0	3	U-4135/0
800002278	50	18	63	50,0	3	U-4135/0
800002279	50	18	100	50,0	3	U-4135/0
800002280	50	18	130	50,0	3	U-4135/0
800002281	50	18	160	50,0	3	U-4135/0
800002282	50	18	200	50,0	3	U-4135/0
800002283	50	20	63	52,0	3	U-4136/0
800002284	50	20	100	52,0	3	U-4136/0
800002285	50	20	130	52,0	3	U-4136/0
800002286	50	20	160	52,0	3	U-4136/0
800002287	50	20	200	52,0	3	U-4136/0
800002288	50	25	80	65,0	4	2x U-4137/0
800002289	50	25	100	65,0	4	2x U-4137/0
800002290	50	25	130	65,0	4	2x U-4137/0
800002291	50	25	160	65,0	4	2x U-4137/0
800002292	50	25	200	65,0	4	2x U-4137/0
800002293	50	32	80	72,0	4	2x U-4138/0
800002294	50	32	100	72,0	4	2x U-4138/0
800002295	50	32	130	72,0	4	2x U-4138/0
800002296	50	32	160	72,0	4	2x U-4138/0
800002297	50	32	200	72,0	4	2x U-4138/0
800002298	50	40	120	90,0	4	2x U-5870/0
800002299	50	40	160	90,0	4	2x U-5870/0
800002300	50	40	200	90,0	4	2x U-5870/0
800002301	50	50	130	100,0	4	2x U-4139/0
800002302	50	50	160	100,0	4	2x U-4139/0
800002303	50	50	200	100,0	4	2x U-4139/0

## 7369 AD+B

■ Frézažské trny pro frézy s příčnou unášecí drážkou

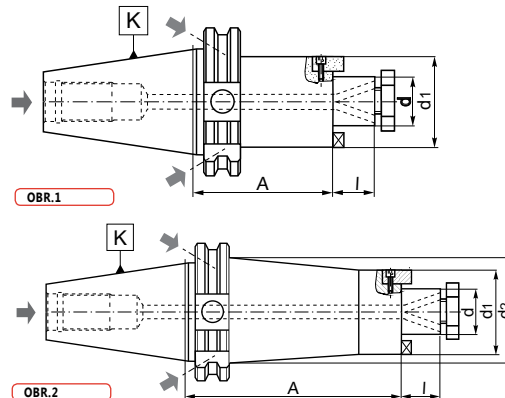

\* pro odpovídající tuhost vyrobeno s kuželem, verze válcová (d1=d2) je na poptávku

Kód výrobku	K 7:24	d	A	l	d <sub>1</sub>	d <sub>2</sub>	Obr.		
800001530	40	16	45	17	38	-	1	U-0620/0	W-1945/0
800001531	40	16	100	17	38	50	2*	U-0620/0	W-1945/0
800001532	40	16	130	17	38	50	2*	U-0620/0	W-1945/0
800001533	40	16	160	17	38	50	2*	U-0620/0	W-1945/0
800001534	40	22	45	19	48	-	1	U-0621/0	W-1946/0
800001535	40	22	100	19	48	-	1	U-0621/0	W-1946/0
800001536	40	22	130	19	48	-	1	U-0621/0	W-1946/0
800001537	40	22	160	19	48	-	1	U-0621/0	W-1946/0
800001538	40	27	60	21	58	-	1	U-0622/0	W-1947/0
800001539	40	27	100	21	58	-	1	U-0622/0	W-1947/0
800001540	40	27	130	21	58	-	1	U-0622/0	W-1947/0
800001541	40	27	160	21	58	-	1	U-0622/0	W-1947/0
800001542	40	32	60	24	66	-	1	U-0623/0	W-1948/0
800001543	40	32	100	24	66	-	1	U-0623/0	W-1948/0
800001544	40	32	130	24	66	-	1	U-0623/0	W-1948/0
800001545	40	32	160	24	66	-	1	U-0623/0	W-1948/0
800001546	40	40	65	27	80	-	1	U-0624/0	W-1949/0
800001547	40	40	100	27	80	-	1	U-0624/0	W-1949/0
800001548	40	40	130	27	80	-	1	U-0624/0	W-1949/0
800001549	40	40	160	27	80	-	1	U-0624/0	W-1949/0
800001550	50	16	50	17	38	-	1	U-0620/0	W-1945/0
800001551	50	16	100	17	38	50	2*	U-0620/0	W-1945/0
800001552	50	16	130	17	38	50	2*	U-0620/0	W-1945/0
800001553	50	16	160	17	38	50	2*	U-0620/0	W-1945/0
800001554	50	16	200	17	38	50	2*	U-0620/0	W-1945/0
800001555	50	22	50	19	48	-	1	U-0621/0	W-1946/0
800001556	50	22	100	19	48	62	2*	U-0621/0	W-1946/0
800001557	50	22	130	19	48	62	2*	U-0621/0	W-1946/0
800001558	50	22	160	19	48	62	2*	U-0621/0	W-1946/0
800001559	50	22	200	19	48	62	2*	U-0621/0	W-1946/0
800001560	50	27	55	21	58	-	1	U-0622/0	W-1947/0
800001561	50	27	100	21	58	70	2*	U-0622/0	W-1947/0
800001562	50	27	130	21	58	70	2*	U-0622/0	W-1947/0
800001563	50	27	160	21	58	70	2*	U-0622/0	W-1947/0
800001564	50	27	200	21	58	70	2*	U-0622/0	W-1947/0
800001565	50	32	60	24	66	-	1	U-0623/0	W-1948/0
800001566	50	32	100	24	66	80	2*	U-0623/0	W-1948/0
800001567	50	32	130	24	66	80	2*	U-0623/0	W-1948/0
800001568	50	32	160	24	66	80	2*	U-0623/0	W-1948/0
800001569	50	32	200	24	66	80	2*	U-0623/0	W-1948/0
800001570	50	40	65	27	80	-	1	U-0624/0	W-1949/0
800001571	50	40	100	27	80	-	1	U-0624/0	W-1949/0
800001572	50	40	130	27	80	-	1	U-0624/0	W-1949/0
800001573	50	40	160	27	80	-	1	U-0624/0	W-1949/0
800001574	50	40	200	27	80	-	1	U-0624/0	W-1949/0
800001575	50	50	70	30	90	-	1	U-0625/0	U-5974/0
800001576	50	50	100	30	90	-	1	U-0625/0	U-5974/0
800001577	50	50	130	30	90	-	1	U-0625/0	U-5974/0
800001578	50	50	160	30	90	-	1	U-0625/0	U-5974/0
800001579	50	50	200	30	90	-	1	U-0625/0	U-5974/0

## 7369 A

■ Frézařské trny pro frézy s příčnou unášecí drážkou

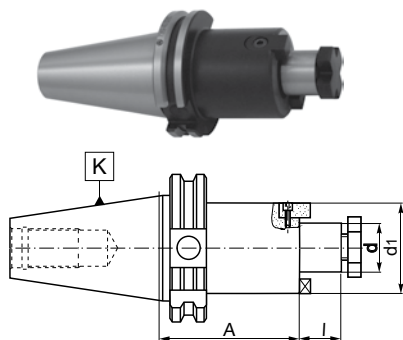

Kód výrobku	K 7:24	d	A	I		
800001506	30	16	35	17	U-0620/0	S-2117/0
800001507	30	22	35	19	U-0621/0	S-2121/0
800001508	30	27	60	21	U-0622/0	S-2111/0
800001509	30	32	60	24	U-0623/0	S-2114/0
800001510	40	16	60	17	U-0620/0	S-2117/0
800001511	40	16	120	17	U-0620/0	S-2117/0
800001512	40	22	60	19	U-0621/0	S-2121/0
800001513	40	22	120	19	U-0621/0	S-2121/0
800001514	40	27	60	21	U-0622/0	S-2111/0
800001515	40	27	120	21	U-0622/0	S-2111/0
800001516	40	32	60	24	U-0623/0	S-2114/0
800001517	40	32	120	24	U-0623/0	S-2114/0
800001518	40	40	60	27	U-0624/0	S-2124/0
800001519	50	16	60	17	U-0620/0	S-2117/0
800001520	50	16	110	17	U-0620/0	S-2117/0
800001521	50	22	60	19	U-0621/0	S-2121/0
800001522	50	22	110	19	U-0621/0	S-2121/0
800001523	50	27	60	21	U-0622/0	S-2111/0
800001524	50	27	110	21	U-0622/0	S-2111/0
800001525	50	32	60	24	U-0623/0	S-2114/0
800001526	50	32	110	24	U-0623/0	S-2114/0
800001527	50	40	60	27	U-0624/0	S-2124/0
800001528	50	40	110	27	U-0624/0	S-2124/0
800001529	50	50	60	30	U-0625/0	U-5974/0

## 7301 A

■ Frézařské trny univerzální

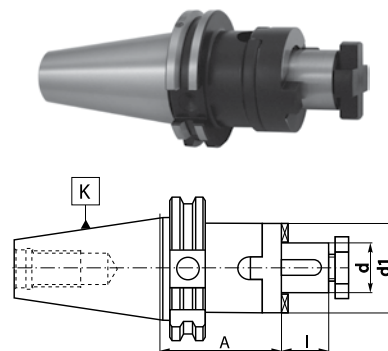

Kód výrobku	K 7:24	d	A	I	d <sub>i</sub>			
800001374	40	16	55	17	32	U-0620/0	U-1364/0	U-1355/0
800001375	40	22	55	19	40	U-0621/0	U-1365/0	U-1356/0
800001376	40	27	55	21	48	U-0622/0	U-1366/0	U-1357/0
800001377	40	32	60	24	58	U-0623/0	U-1367/0	U-6355/0
800001378	40	40	60	27	70	U-0624/0	U-1368/0	U-1359/0
800001379	50	16	55	17	32	U-0620/0	U-1364/0	U-1355/0
800001380	50	22	55	19	40	U-0621/0	U-1365/0	U-1356/0
800001381	50	27	55	21	48	U-0622/0	U-1366/0	U-1357/0
800001382	50	32	55	24	58	U-0623/0	U-1367/0	U-6355/0
800001383	50	40	55	27	70	U-0624/0	U-1368/0	U-1359/0
800001384	50	50	70	30	90	U-0625/0	U-1369/0	U-1360/0

## 7669 AD+B

■ Frézařské trny pro frézy se závitem

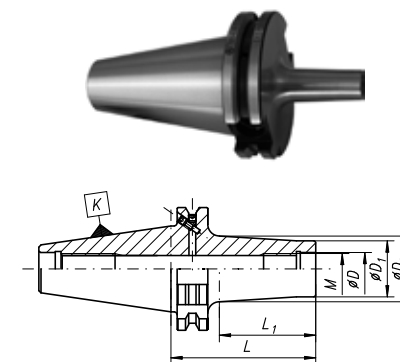

Kód výrobku	K 7:24	M	L	L1	D	D <sub>1</sub>	D <sub>2</sub>
800006890	40	M8	55	30	8,5	13	15
800006891	40	M8	75	50	8,5	13	23
800006892	40	M8	95	70	8,5	13	23
800006893	40	M8	115	90	8,5	13	25
800006894	40	M10	55	30	10,5	18	20
800006895	40	M10	75	50	10,5	18	25
800006896	40	M10	95	70	10,5	18	28
800006897	40	M10	115	90	10,5	18	34
800006898	40	M10	145	120	10,5	18	34
800006899	40	M12	55	30	12,5	21	24
800006900	40	M12	75	50	12,5	21	24
800006901	40	M12	95	70	12,5	21	31
800006902	40	M12	115	90	12,5	21	31
800006903	40	M12	145	120	12,5	21	38
800006904	40	M12	175	153	12,5	21	42
800006905	40	M16	55	30	17	29	34
800006906	40	M16	75	50	17	29	34
800006907	40	M16	95	70	17	29	34
800006908	40	M16	115	92	17	29	39
800006909	40	M16	145	122	17	29	39
800006910	40	M16	175	160	17	29	39
800006911	50	M10	85	60	10,5	18	28
800006912	50	M10	135	110	10,5	18	28
800006913	50	M10	185	160	10,5	18	32
800006914	50	M12	85	60	12,5	21	32
800006915	50	M12	135	110	12,5	21	32
800006916	50	M12	185	160	12,5	21	36
800006917	50	M16	85	60	17	29	36
800006918	50	M16	135	110	17	29	40
800006919	50	M16	185	160	17	29	42

1

2

3

4

5

6

7

## 7373 A

■ Frézařské trny pro kotoučové frézy

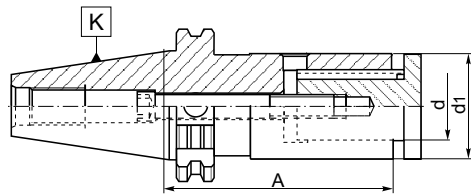

Kód výrobku	K 7:24	d	d <sub>1</sub>	A	Rozsah upínání			
800001596	40	16	29	95	0-10	U-6520/0	U-6510/0	U-6526/0
800001597	40	16	29	125	0-16	U-6520/0	U-6511/0	U-6527/0
800001598	40	22	36	95	0-10	U-6523/0	U-6512/0	U-6528/0
800001599	40	22	36	125	0-20	U-6523/0	U-6513/0	U-6529/0
800001600	40	27	42	95	0-10	U-6523/0	U-6514/0	U-6530/0
800001601	40	27	42	125	0-20	U-6523/0	U-6515/0	U-6531/0
800001602	40	32	50	95	0-10	U-6523/0	U-6516/0	U-6532/0
800001603	40	32	50	125	0-20	U-6523/0	U-6517/0	U-6533/0
800001604	50	22	36	100	0-10	U-6524/0	U-6512/0	U-6528/0
800001605	50	22	36	125	0-20	U-6524/0	U-6513/0	U-6529/0
800001606	50	27	42	100	0-10	U-6524/0	U-6514/0	U-6530/0
800001607	50	27	42	125	0-20	U-6524/0	U-6515/0	U-6531/0
800001608	50	32	50	100	0-10	U-6524/0	U-6516/0	U-6532/0
800001609	50	32	50	125	0-20	U-6524/0	U-6517/0	U-6533/0
800001610	50	40	58	100	0-10	U-6524/0	U-6518/0	U-6534/0
800001611	50	40	58	125	0-20	U-6524/0	U-6519/0	U-6535/0

## 2827 A

■ Frézařské trny pro frézovací hlavy

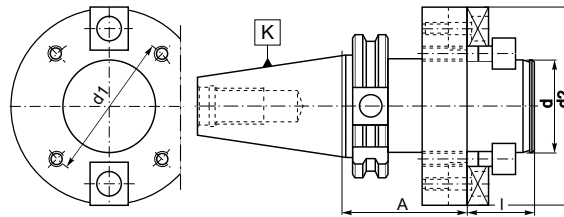

Kód výrobku	K 7:24	d	d <sub>1</sub>	d <sub>2</sub>	A	l		
800000600	40	40	66,7	89	60	30	U-6064/0	U-1414/0
800000601	40	60	101,6	129	60	40	U-6066/0	U-2042/0
800000602	50	40	66,7	89	70	30	U-6064/0	U-1414/0
800000603	50	60	101,6	129	70	40	U-6066/0	U-2042/0

## 1606 AD

■ Držáky s axiálním nastavením dle DIN 6327

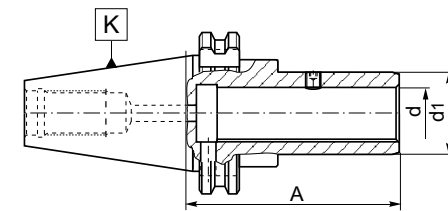

Kód výrobku	K	DIN 6327	d <sub>1</sub>	a	
800000066	40	16	25	75	U-1997/0
800000067	40	20	32	80	U-1997/0
800000068	40	28	40	100	U-7381/0
800000069	40	36	50	115	U-7381/0
800000070	50	16	25	85	U-1997/0
800000071	50	20	32	85	U-1997/0
800000072	50	28	40	100	U-7381/0
800000073	50	36	50	100	U-7381/0
800000074	50	48	67	105	U-7382/0

- 1
- 2
- 3
- 4
- 5
- 6
- 7

## 7655 A

- Vrtací sklíčidlo samosvorné
- Klíč je součástí dodávky

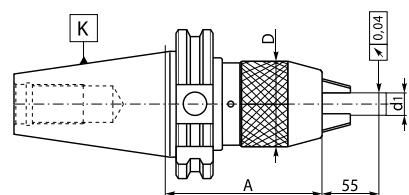

Kód výrobku	K 7:24	d <sub>1</sub>	A	D
800002390	40	1-13	87	50
800002391	40	3-16	106	57
800002392	50	1-13	87	50
800002393	50	3-16	90	57

## 7660 A

- Vrtací sklíčidlo pro pravé i levé otáčky upínané "inbus" klíčem
- Klíč je součástí dodávky

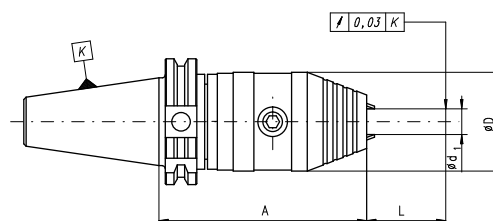

Kód výrobku	K 7:24	d <sub>1</sub>	Upínací moment	A	D
800006585	40	1-13	40Nm	105	50
800006586	40	3-16	45Nm	105	50
800006587	50	1-13	40Nm	105	50
800006588	50	3-16	45Nm	105	50

## 1681 AD

- Univerzální redukční pouzdra pro nástroje se stopkou Morse se závitem nebo unašečem

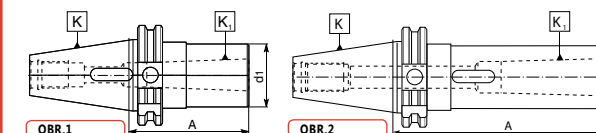

\* pouze pro nástroje s kuželem Morse dle DIN 228-B

Kód výrobku	K 7:24	K <sub>1</sub> MK	A	d <sub>1</sub>	Obr.
800000209	30	1	50	25	1
800000210	30	2*	60	32	1
800000211	30	3*	80	40	1
800000212	40	1	50	25	1
800000214	40	2	50	32	1
800000216	40	3*	70	40	1
800000218	40	4*	95	48	1
800000213	40	1	120	25	2
800000215	40	2	120	32	2
800000217	40	3*	135	40	2
800000219	40	4*	165	48	2
800000220	50	1	45	25	1
800000222	50	2	60	32	1
800000224	50	3	65	40	1
800000226	50	4	95	48	1
800000228	50	5*	105	63	1
800000221	50	1	120	25	2
800000223	50	2	135	32	2
800000225	50	3	155	40	2
800000227	50	4	180	48	2
800000229	50	5*	215	63	2

1  
2  
3  
4  
5  
6  
7

## 1695 AD

- Redukční pouzdra pro nástroje s kuzelem Morse se závitem

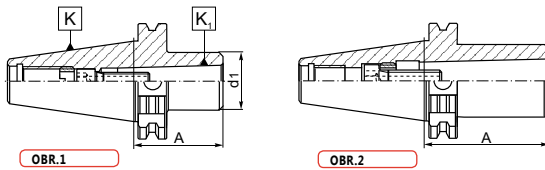

Kód výrobku	K 7:24	K <sub>1</sub> MK	A	d <sub>1</sub>	Obr.	
800000266	30	1	50	25	1	W-1091/0
800000267	30	2	60	32	2	W-1095/0
800000268	30	3	85	40	2	U-7790/0
800000269	40	1	50	25	1	W-1091/0
800000270	40	2	50	32	1	W-1092/0
800000271	40	3	70	40	2	W-1093/0
800000272	40	4	95	48	2	W-1094/0
800000273	50	1	45	25	1	W-1091/0
800000274	50	2	60	32	1	W-1095/0
800000275	50	3	65	40	1	W-1096/0
800000276	50	4	95	48	1	W-1097/0
800000277	50	5	120	63	2	W-1098/0

## 1681 AD+B

- Univerzální redukční pouzdra pro nástroje se stopkou Morse se závitem nebo unašečem

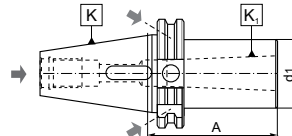



\* pouze pro nástroje s kuzelem Morse dle DIN 228-B

Kód výrobku	K 7:24	K <sub>1</sub> MK	A	d <sub>1</sub>
800000230	40	2	50	32
800000231	40	3*	70	40
800000232	40	4*	95	48
800000233	50	2	60	32
800000234	50	3	65	40
800000235	50	4	95	48
800000236	50	5*	120	63

## 1682 A

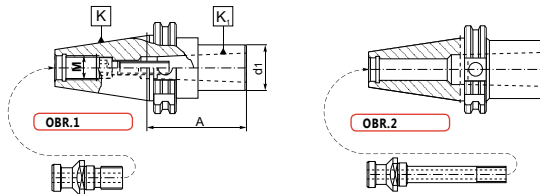
- Redukční pouzdra pro nástroje s kuzelem Morse se závitem
- Pro upnutí nástroje u varianty 2 je třeba spec. dlouhý čep typu 9882!



Kód výrobku	K 7:24	K <sub>1</sub> MK	A	d <sub>1</sub>	M	Obr.	
800000237	40	1	45	25	M16	1	W-1091/0
800000238	40	2	60	32	M16	1	W-1092/0
800000239	40	3	75	40	—	2	—
800000240	40	4	85	48	—	2	—
800000241	50	1	45	25	M24	1	W-1091/0
800000242	50	2	45	32	M24	1	W-1095/0
800000243	50	3	60	40	M24	1	W-1096/0
800000244	50	4	75	48	M24	1	U-5984/0
800000245	50	5	75	63	—	2	—

## 1695 AD+B

- Redukční pouzdra pro nástroje s kuzelem Morse se závitem

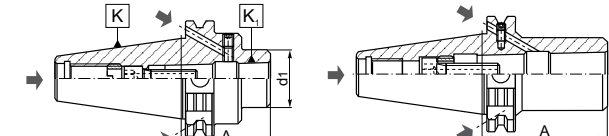

Kód výrobku	K 7:24	K <sub>1</sub> MK	A	d <sub>1</sub>	Obr.	
800000278	40	2	50	32	1	W-1092/0
800000279	40	3	70	40	2	W-1093/0
800000280	40	4	95	48	2	W-1094/0
800000281	50	2	60	32	1	W-1095/0
800000282	50	3	65	40	1	W-1096/0
800000283	50	4	95	48	1	W-1097/0
800000284	50	5	120	63	2	W-1098/0

## 1684 AD

- Redukční pouzdra pro nástroje s kuzelem 7:24

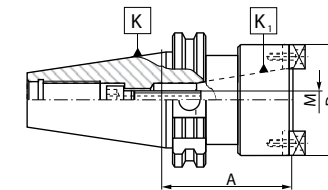

Kód výrobku	K 7:24	K <sub>1</sub> 7:24	A	D	M	
800000246	50	40	80	88	M16	U-6227/0

## 7630 AD

- Tepelné upínáče
- Vhodné pro HSS a tvrdokovové nástroje s válcovou stopkou (tolerance h6)
- Max. házivost = 0,003mm
- Max. ohřivací teplota 500°C
- Provedení s úhlem 3° je dostupné na objednávku

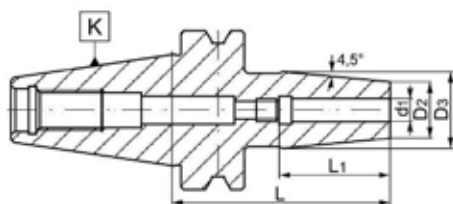

\* Provedení 3°- na objednávku!

Kód výrobku	K 7:24	d <sub>1</sub>	L	L <sub>1</sub>	D <sub>2</sub>	D <sub>3</sub>
800006333	40	3	80	36	14	22
800006334	40	3	120	36	14	22
800006335	40	3	160	36	14	22
800006336	40	4	80	36	14	22
800006337	40	4	120	36	14	22
800006338	40	4	160	36	15	22
800006339	40	5	80	36	16	22
800006340	40	5	120	36	16	22
800006341	40	5	160	36	16	22
800006342	40	6	80	36	21	27
800006343	40	6	120	36	21	27
800006344	40	6	160	36	21	27
800006345	40	8	80	36	21	27
800006346	40	8	120	36	21	27
800006347	40	8	160	36	21	27
800006348	40	10	80	42	24	32
800006349	40	10	120	42	24	32
800006350	40	10	160	42	24	32
800006351	40	12	80	47	24	32
800006352	40	12	120	47	24	32
800006353	40	12	160	47	24	32
800006354	40	14	80	47	27	34
800006355	40	14	120	47	27	34
800006356	40	14	160	47	27	34
800006357	40	16	80	50	27	34
800006358	40	16	120	50	27	34
800006359	40	16	160	50	27	34
800006360	40	18	80	50	33	42
800006361	40	18	120	50	33	42
800006362	40	18	160	50	33	42
800006363	40	20	80	52	33	42
800006364	40	20	120	52	33	42
800006365	40	20	160	52	33	42
800006366	40	25	100	58	44	53
800006367	40	25	120	58	44	53
800006368	40	25	160	58	44	53
800006369	40	32	100	58	44	53
800006370	40	32	120	58	44	53
800006371	40	32	160	58	44	53

Kód výrobku	K 7:24	d <sub>1</sub>	L	L <sub>1</sub>	D <sub>2</sub>	D <sub>3</sub>
800006372	50	6	80	36	21	27
800006373	50	6	120	36	21	27
800006374	50	6	160	36	21	27
800006375	50	8	80	36	21	27
800006376	50	8	120	36	21	27
800006377	50	8	160	36	21	27
800006378	50	10	80	42	24	32
800006379	50	10	120	42	24	32
800006380	50	10	160	42	24	32
800006381	50	12	80	47	24	32
800006382	50	12	120	47	24	32
800006383	50	12	160	47	24	32
800006384	50	14	80	47	27	34
800006385	50	14	120	47	27	34
800006386	50	14	160	47	27	34
800006387	50	16	80	50	27	34
800006388	50	16	120	50	27	34
800006389	50	16	160	50	27	34
800006390	50	18	80	50	33	42
800006391	50	18	120	50	33	42
800006392	50	18	160	50	33	42
800006393	50	20	80	52	33	42
800006394	50	20	120	52	33	42
800006395	50	20	160	52	33	42
800006396	50	25	100	58	44	53
800006397	50	25	120	58	44	53
800006398	50	25	160	58	44	53
800006399	50	32	100	58	44	53
800006400	50	32	120	58	44	53
800006401	50	32	160	58	44	53

■ Jiné rozměry jsou na poptávku



## 2191 A

■ Polotovary

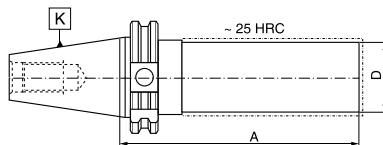

Kód výrobku	K 7:24	D	A
80000566	40	40	280
80000569	40	63	280
80000571	50	50	330
80000574	50	80	330
80000577	50	97	315

## 9882 A

■ Upínací čepy s průchozím otvorem pro přívod chladiva (DIN 69872-A)

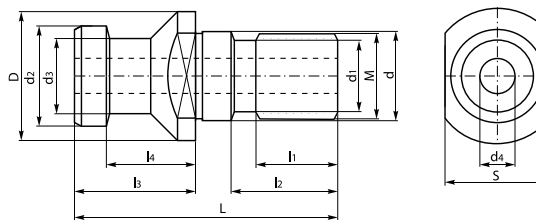

Kód výrobku	Velikost	L	D	d	d <sub>1</sub>	d <sub>2</sub>	d <sub>3</sub>	d <sub>4</sub>	M	l <sub>1</sub>	l <sub>2</sub>	l <sub>3</sub>	l <sub>4</sub>	S
800002996	30	44	17	13	10,00	13	9	3,00	M12	10	15	24	19	14
800002997	40	54	23	17	13,50	19	14	7,00	M16	15	21	26	20	19
800002998	40	85	23	17	8,50	19	14	4,00	M10	10	52	26	20	19
800003001	40	110	23	17	10,00	19	14	5,00	M12	12	77	26	20	19
800002999	40	86	23	17	13,50	19	14	7,00	M16	15	53	26	20	19
800003002	40	111	23	17	13,50	19	14	7,00	M16	15	78	26	20	19
800003000	40	108	23	17	13,50	19	14	7,00	M16	15	75	26	20	19
800003003	50	74	36	25	20,00	28	21	11,50	M24	23	30	34	25	30
800003507	50	110	36	25	16,50	28	21	7,00	M20	23	66	34	25	30

■ Upínací čepy jiných rozměrů nebo dle jiných norem (dle ISO 7388/2B a podobně) jsou na objednávku

## 9882 AS

■ Upínací čepy s průchozím otvorem pro přívod chladiva - pro stroje HAAS

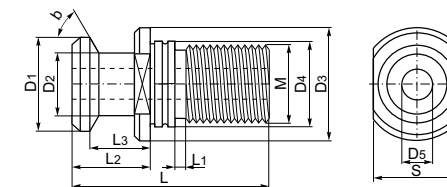

Kód	Velikost	L	b	D3	D4	D1	D2	D5	M	l <sub>2</sub>	S
800006235	40	57	45°	23	17	15	10	4	M16	32	19

## 2852

■ Kontrolní try

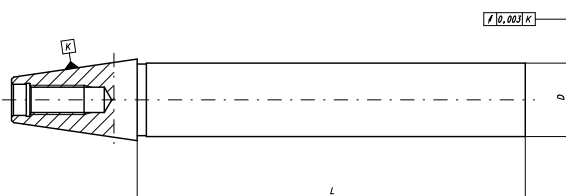

Kód výrobku	K 7:24	D	L
800006692	40	40	300
800006693	50	50	300

## 9882 B

■ Upínací čepy bez průchozího otvoru (DIN 69872-B)

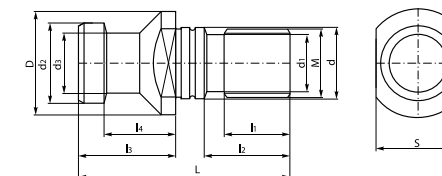

Kód výrobku	Velikost	L	D	d	d <sub>1</sub>	d <sub>2</sub>	d <sub>3</sub>	M	l <sub>1</sub>	l <sub>2</sub>	l <sub>3</sub>	l <sub>4</sub>	S
800003004	30	44	17	13	10,00	13	9	M12	10	15	24	19	14
800003005	40	54	23	17	13,50	19	14	M16	15	21	26	20	19
800003006	50	74	36	25	20,00	28	21	M24	23	30	34	25	30

## MAS 403-BT

- Materiál: legovaná ocel chrom-manganová
- Cementováno do hloubky 0,7mm
- Kaleno a přesně broušeno
- Tvrdost povrchů 58±2 HRC
- Tolerance úhlu kuželu AT3

### Význam dodatkových písmen

- A = verze bez vnitřního chlazení
- AD = verze s přívodem chlazení středem vřetene (přes upínací čep)
- B = verze s přívodem chlazení z límce upínáče
- AD+B = kombinace AD a B

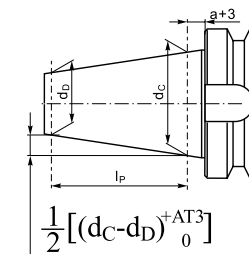
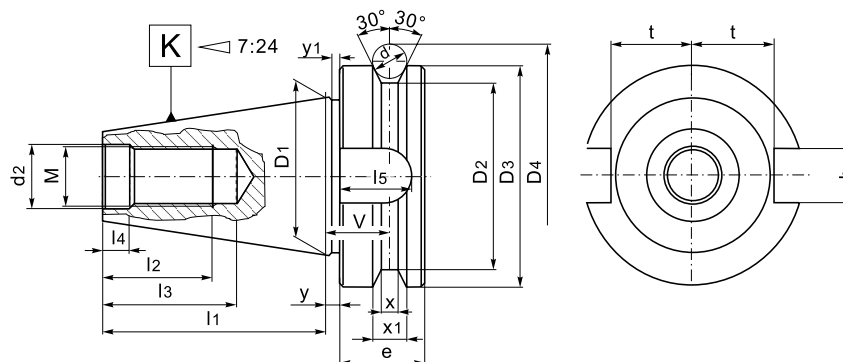

K 7:24	d <sub>c</sub> -d <sub>b</sub>	l <sub>p</sub>	a	AT3
30	12,250	42	2	0,002
40	17,208	59	2	0,003
50	26,833	92	3	0,004

K 7:24	D <sub>1</sub>	D <sub>2</sub>	D <sub>3</sub>	D <sub>4</sub>	l <sub>1</sub>	l <sub>2</sub>	l <sub>3</sub>	l <sub>4</sub>	l <sub>5</sub>	bH12	t	d	d <sub>2</sub> H7	M	e	v	x	x <sub>1</sub>	y	y <sub>1</sub>
30	31,75	38	46	56,1	48,4	24	34	7	17	16,1	16,3	8	12,5	M12	20	13,6	4	8	2	2
40	44,45	53	63	75,6	65,4	30	43	9	21	16,1	22,6	10	17,0	M16	25	16,6	5	10	2	2
50	69,85	85	100	119,0	101,8	45	62	13	31	25,7	35,4	15	25,0	M24	35	23,2	7	15	3	3

## 7626 AD

## 7626 AD+B

- Kleštinové upínáče pro kleštiny ER (DIN 6499)



**AD**

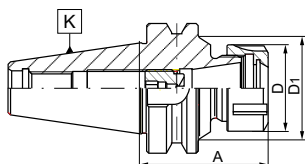

**AD+B**

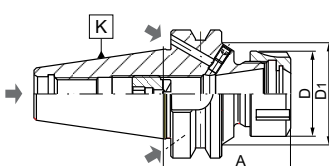

Kód výrobku	K 7:24	Klešтина	A	Provedení	Rozsah upínání	D	D <sub>1</sub>		
800002304	30	ER16	60	AD	2-10	32	26	9833-16ES	M10x11LH
800003719	30	ER25	60	AD	2-16	42	37	9833-25ES	M18x1,5x19LH
800002305	30	ER32	60	AD	2-20	50	45	9833-32ES	M18x1,5x19LH
800003720	40	ER16	60	AD	2-10	32	28	9833-16ES	M12x1,5x14LH
800002452	40	ER16	60	AD+B	2-10	32	50	9833-16ES	M12x1,5x14LH
800002306	40	ER25	60	AD	2-16	42	29	9833-25ES	M18x1,5x19LH
800002453	40	ER25	60	AD+B	2-16	42	52	9833-25ES	M18x1,5x19LH
800004914	40	ER25	100	AD	2-16	42	37	9833-25ES	M18x1,5x19LH
800006783	40	ER25	130	AD	2-16	42	37	9833-25ES	M18x1,5x19LH
800006784	40	ER25	160	AD+B	2-16	42	52	9833-25ES	M18x1,5x19LH
800002307	40	ER32	70	AD	2-20	50	37	9833-32ES	M22x1,5x24LH
800002454	40	ER32	70	AD+B	2-20	50	52	9833-32ES	M22x1,5x24LH
800006785	40	ER32	100	AD	2-20	50	40	9833-32ES	M22x1,5x24LH
800002308	40	ER32	130	AD	2-20	50	40	9833-32ES	M22x1,5x24LH
800002455	40	ER32	160	AD+B	2-20	50	52	9833-32ES	M22x1,5x24LH
800002309	40	ER40	70	AD	2-26	63	47	9833-40ES	M28x1,5x30LH
800002456	40	ER40	70	AD+B	2-26	63	47	9833-40ES	M28x1,5x30LH
800002310	40	ER40	80	AD	2-26	63	47	9833-40ES	M28x1,5x30LH

Kód výrobku	K 7:24	Klešтина	A	Provedení	Rozsah upínání	D	D <sub>1</sub>		
800002311	50	ER32	70	AD	2-20	50	37	9833-32ES	M22x1,5x24LH
800002457	50	ER32	70	AD+B	2-20	50	37	9833-32ES	M22x1,5x24LH
800002312	50	ER32	130	AD	2-20	50	37	9833-32ES	M22x1,5x24LH
800002458	50	ER32	160	AD+B	2-20	50	80	9833-32ES	M22x1,5x24LH
800002313	50	ER40	80	AD	2-26	63	55	9833-40ES	M28x1,5x30LH
800002459	50	ER40	80	AD+B	2-26	63	80	9833-40ES	M28x1,5x30LH
800002451	50	ER40	130	AD	2-26	63	55	9833-40ES	M28x1,5x30LH
800002460	50	ER40	160	AD+B	2-26	63	80	9833-40ES	M28x1,5x30LH

Jiné rozměry jsou dostupné na poptávku

Například:

- 40-ER11Mini, 40-ER16Mini, 40-ER25Mini (v délkách A=100, 150, 200)
- 40-ER16 (A=200)
- 40-ER20 (A=70,100,120,150)
- 40-ER25-200
- 40-ER32-200
- 40-ER40 (A=100, 130, 150, 200)
- a další !

1  
2  
3  
4  
5  
6  
7

**7626-S AD**

**7626-S AD+B**

■ Kleštinové upínače pro kleštiny ER (DIN 6499) prodloužené



**AD**

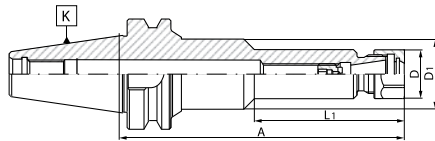

**AD+B**

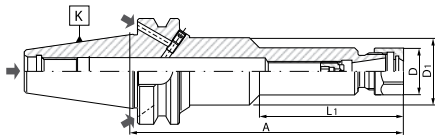

Kód výrobku	K 7:24	Kleština	A	Provedení	Rozsah upínání	L <sub>1</sub>	D	D <sub>1</sub>		
800002465	40	ER16	100	AD+B	2-10	—	28	—	9833-16D	M12x1,5x14LH
800002461	40	ER16	100	AD	2-10	—	28	—	9833-16D	M12x1,5x14LH
800002462	40	ER16	150	AD	2-10	85	28	40	9833-16D	M12x1,5x14LH
800002466	40	ER16	160	AD+B	2-10	86	28	40	9833-16D	M12x1,5x14LH
800002467	50	ER16	100	AD+B	2-10	—	28	—	9833-16D	M12x1,5x14LH
800002463	50	ER16	100	AD	2-10	—	28	—	9833-16D	M12x1,5x14LH
800002464	50	ER16	150	AD	2-10	85	28	40	9833-16D	M12x1,5x14LH
800002468	50	ER16	160	AD+B	2-10	86	28	40	9833-16D	M12x1,5x14LH

**7626-KPL**

**7626-PL**

**7626-S PL**

■ Kleštinové upínače pro kleštiny ER (DIN 6499) se sadou kleštin



Kód výrobku	K 7:24	Kleštiny	A	Rozsah upínání	Počet kleštin v sadě
<b>7626-KPL</b>					
800002469	30	ER16	60	2-10	8
800002470	30	ER32	60	2-20	18
800002471	40	ER25	60	2-16	14
800002472	40	ER32	70	2-20	18
800002314	40	ER32	130	2-20	18
800002315	40	ER40	70	2-26	24
800002316	50	ER32	70	2-20	18
800002317	50	ER32	130	2-20	18
800002318	50	ER40	80	2-26	24
800002319	50	ER40	130	2-26	24
<b>7626-PL</b>					
800002324	30	ER32	60	3-20	8
Kleštiny • Ø 4,5,6,8,10,12,16,20					
800002325	40	ER32	70	3-20	8
Kleštiny • Ø 4,5,6,8,10,12,16,20					
800002326	50	ER32	70	3-20	8
Kleštiny • Ø 4,5,6,8,10,12,16,20					
<b>7626-S PL</b>					
800002320	40	ER16	100	2-10	8
800002321	40	ER16	150	2-10	8
800002322	50	ER16	100	2-10	8
800002323	50	ER16	150	2-10	8

**7629 AD**

■ Frézařské trny pro nástroje s válcovou stopkou dle DIN 1835-E (Whistle-Notch)

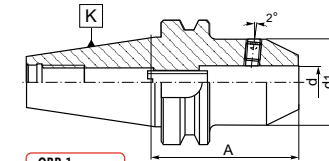

OBR.1

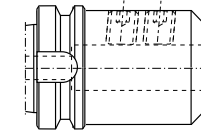

OBR.2

Kód výrobku	K 7:24	d	d <sub>1</sub>	A	Obr.		
800002369	40	6	25	50	1	U-4131/0	U-1599/0
800002370	40	8	28	50	1	U-4132/0	U-6317/0
800002371	40	10	35	63	1	U-4133/0	U-0293/0
800002372	40	12	42	63	1	U-4134/0	U-0757/0
800002373	40	14	44	63	1	U-4135/0	U-6318/0
800002374	40	16	48	63	1	U-4135/0	U-6318/0
800002375	40	18	50	63	1	U-4136/0	U-6793/0
800002376	40	20	52	63	1	U-4136/0	U-6793/0
800002377	40	25	65	90	2	2x U-4137/0	U-6794/0
800002378	40	32	72	100	2	2x U-4138/0	U-6794/0
800002379	50	6	25	63	1	U-4131/0	U-1599/0
800002380	50	8	28	63	1	U-4132/0	U-6317/0
800002381	50	10	35	65	1	U-4133/0	U-0293/0
800002382	50	12	42	80	1	U-4134/0	U-0757/0
800002383	50	14	44	80	1	U-4135/0	U-6318/0
800002384	50	16	48	80	1	U-4135/0	U-6318/0
800002385	50	18	50	80	1	U-4136/0	U-6793/0
800002386	50	20	52	80	1	U-4136/0	U-6793/0
800002387	50	25	65	100	2	2x U-4137/0	U-6794/0
800002388	50	32	72	105	2	2x U-4138/0	U-6794/0
800002389	50	40	90	120	2	2x U-5870/0	U-6794/0

## 7624 AD

■ Frézařské trny pro nástroje s válcovou stopkou dle DIN 1835-B (WELDON)

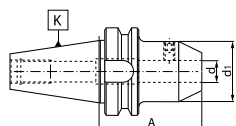

OBR. 1

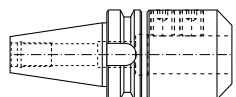

OBR. 2

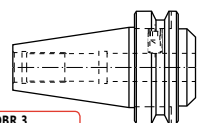

OBR. 3

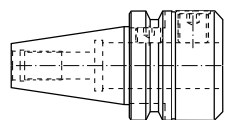

OBR. 4

Kód výrobku	K 7:24	d	A	d <sub>1</sub>	Obr.	
800002001	30	6	50	25	1	U-4131/0
800002002	30	8	50	28	1	U-4132/0
800002003	30	10	50	35	1	U-4133/0
800002004	30	12	50	42	1	U-4134/0
800002005	30	16	63	48	1	U-4135/0
800002006	30	20	63	52	1	U-4136/0
800002007	40	6	35	25	3	U-4131/0
800002008	40	6	50	25	1	U-4131/0
800002009	40	8	35	28	3	U-4132/0
800002010	40	8	50	28	1	U-4132/0
800002011	40	10	37	35	3	U-4133/0
800002012	40	10	63	35	1	U-4133/0
800002013	40	12	37	42	3	U-4134/0
800002014	40	12	63	42	1	U-4134/0
800002015	40	14	37	44	3	U-4134/0
800002016	40	14	63	44	1	U-4134/0
800002017	40	16	37	48	3	U-4135/0
800002018	40	16	63	48	1	U-4135/0
800002020	40	20	37	50	3	U-6756/0
800002021	40	20	63	50	1	U-4136/0
800002022	40	25	60	63	4	U-4137/0 + U-6755/0
800002023	40	25	90	63	2	U-4138/0 + U-6755/0
800002024	40	32	65	72	4	2x U-6755/0
800002025	40	32	100	72	2	2x U-4138/0
800002026	50	6	63	25	1	U-4131/0
800002027	50	8	63	28	1	U-4132/0
800002028	50	10	63	35	1	U-4133/0
800002029	50	12	80	42	1	U-4134/0
800002030	50	14	80	44	1	U-4134/0
800002031	50	16	80	48	1	U-4135/0
800002032	50	20	40	52	3	U-4136/0
800002033	50	20	80	52	1	U-4136/0
800002034	50	25	60	63	4	2x U-4137/0
800002035	50	25	100	63	2	2x U-4137/0
800002036	50	32	70	72	4	2x U-4138/0
800002037	50	32	105	72	2	2x U-4138/0
800002038	50	40	120	90	2	2x U-5870/0
800002039	50	50	130	100	2	2x U-4139/0

## 7624 AD+B

■ Frézařské trny pro nástroje s válcovou stopkou dle DIN 1835-B (WELDON)

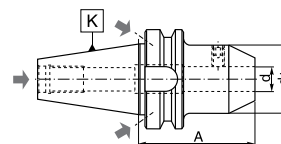

OBR. 1

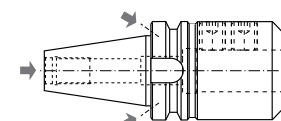

OBR. 2

Kód výrobku	K 7:24	d	A	d <sub>1</sub>	Obr.	
800002040	40	6	50	25,0	1	U-4131/0
800002041	40	6	100	25,0	1	U-4131/0
800002042	40	6	130	25,0	1	U-4131/0
800002043	40	6	160	25,0	1	U-4131/0
800002044	40	6	200	25,0	1	U-4131/0
800002045	40	8	50	28,0	1	U-4132/0
800002046	40	8	100	28,0	1	U-4132/0
800002047	40	8	130	28,0	1	U-4132/0
800002048	40	8	160	28,0	1	U-4132/0
800002049	40	8	200	28,0	1	U-4132/0
800002050	40	10	60	35,0	1	U-4133/0
800002051	40	10	100	35,0	1	U-4133/0
800002052	40	10	130	35,0	1	U-4133/0
800002053	40	10	160	35,0	1	U-4133/0
800002054	40	10	200	35,0	1	U-4133/0
800002055	40	12	60	42,0	1	U-4134/0
800002056	40	12	100	42,0	1	U-4134/0
800002057	40	12	130	42,0	1	U-4134/0
800002058	40	12	160	42,0	1	U-4134/0
800002059	40	12	200	42,0	1	U-4134/0
800002060	40	14	60	44,0	1	U-4134/0
800002061	40	14	100	44,0	1	U-4134/0
800002062	40	14	130	44,0	1	U-4134/0
800002063	40	14	160	44,0	1	U-4134/0
800002064	40	14	200	44,0	1	U-4134/0
800002065	40	16	63	48,0	1	U-4135/0
800002066	40	16	100	48,0	1	U-4135/0
800002067	40	16	130	48,0	1	U-4135/0
800002068	40	16	160	48,0	1	U-4135/0
800002069	40	16	200	48,0	1	U-4135/0
800002070	40	18	63	49,5	1	U-4135/0
800002071	40	18	100	49,5	1	U-4135/0
800002072	40	18	130	49,5	1	U-4135/0
800002073	40	18	160	49,5	1	U-4135/0
800002074	40	18	200	49,5	1	U-4135/0
800002075	40	20	63	49,5	1	U-4136/0
800002076	40	20	100	49,5	1	U-4136/0
800002077	40	20	130	49,5	1	U-4136/0
800002078	40	20	160	49,5	1	U-4136/0
800002079	40	20	200	49,5	1	U-4136/0
800002080	40	25	100	63,0	2	2x U-4137/0
800002081	40	25	130	63,0	2	2x U-4137/0
800002082	40	25	160	63,0	2	2x U-4137/0
800002083	40	25	200	63,0	2	2x U-4137/0
800002084	40	32	100	72,0	2	2x U-4138/0
800002085	40	32	130	72,0	2	2x U-4138/0
800002086	40	32	160	72,0	2	2x U-4138/0
800002087	40	32	200	72,0	2	2x U-4138/0
na požádání	40	40	120	90,0	4	2x U-5870/0

1  
2  
3  
4  
5  
6  
7

Kód výrobku	K 7:24	d	A	d <sub>1</sub>	Obr.	
800002083	40	25	200	63,0	2	2x U-4137/0
800002084	40	32	100	72,0	2	2x U-4138/0
800002085	40	32	130	72,0	2	2x U-4138/0
800002086	40	32	160	72,0	2	2x U-4138/0
800002087	40	32	200	72,0	2	2x U-4138/0
800002088	50	6	63	25,0	1	U-4131/0
800002089	50	6	100	25,0	1	U-4131/0
800002090	50	6	130	25,0	1	U-4131/0
800002091	50	6	160	25,0	1	U-4131/0
800002092	50	6	200	25,0	1	U-4131/0
800002093	50	8	63	28,0	1	U-4132/0
800002094	50	8	100	28,0	1	U-4132/0
800002095	50	8	130	28,0	1	U-4132/0
800002096	50	8	160	28,0	1	U-4132/0
800002097	50	8	200	28,0	1	U-4132/0
800002098	50	10	70	35,0	1	U-4133/0
800002099	50	10	100	35,0	1	U-4133/0
800002100	50	10	130	35,0	1	U-4133/0
800002101	50	10	160	35,0	1	U-4133/0
800002102	50	10	200	35,0	1	U-4133/0
800002103	50	12	80	42,0	1	U-4134/0
800002104	50	12	100	42,0	1	U-4134/0
800002105	50	12	130	42,0	1	U-4134/0
800002106	50	12	160	42,0	1	U-4134/0
800002107	50	12	200	42,0	1	U-4134/0
800002108	50	14	80	44,0	1	U-4134/0
800002109	50	14	100	44,0	1	U-4134/0
800002110	50	14	130	44,0	1	U-4134/0
800002111	50	14	160	44,0	1	U-4134/0
800002112	50	14	200	44,0	1	U-4134/0
800002113	50	16	80	48,0	1	U-4135/0
800002114	50	16	100	48,0	1	U-4135/0
800002115	50	16	130	48,0	1	U-4135/0
800002116	50	16	160	48,0	1	U-4135/0
800002117	50	16	200	48,0	1	U-4135/0
800002118	50	18	80	50,0	1	U-4135/0
800002119	50	18	100	50,0	1	U-4135/0
800002120	50	18	130	50,0	1	U-4135/0
800002121	50	18	160	50,0	1	U-4135/0
800002122	50	18	200	50,0	1	U-4135/0
800002123	50	20	80	52,0	1	U-4136/0
800002124	50	20	100	52,0	1	U-4136/0
800002125	50	20	130	52,0	1	U-4136/0
800002126	50	20	160	52,0	1	U-4136/0
800002127	50	20	200	52,0	1	U-4136/0
800002128	50	25	100	65,0	2	2x U-4137/0
800002129	50	25	130	65,0	2	2x U-4137/0
800002130	50	25	160	65,0	2	2x U-4137/0
800002131	50	25	200	65,0	2	2x U-4137/0
800002132	50	32	105	72,0	2	2x U-4138/0
800002133	50	32	130	72,0	2	2x U-4138/0
800002134	50	32	160	72,0	2	2x U-4138/0
800002135	50	32	200	72,0	2	2x U-4138/0
800002136	50	40	120	90,0	2	2x U-5870/0
800002137	50	40	160	90,0	2	2x U-5870/0
800002138	50	40	200	90,0	2	2x U-5870/0

Kód výrobku	K 7:24	d	A	l	d <sub>1</sub>	d <sub>2</sub>	Obr.		
800001636	40	16	45	17	38	-	1	U-0620/0	W-1945/0
800001637	40	16	100	17	38	50	2*	U-0620/0	W-1945/0
800001638	40	16	130	17	38	50	2*	U-0620/0	W-1945/0
800001639	40	16	160	17	38	50	2*	U-0620/0	W-1945/0
800001640	40	22	45	19	48	-	1	U-0621/0	W-1946/0
800001641	40	22	100	19	48	-	1	U-0621/0	W-1946/0
800001642	40	22	130	19	48	-	1	U-0621/0	W-1946/0
800001643	40	22	160	19	48	-	1	U-0621/0	W-1946/0
800001644	40	27	50	21	58	-	1	U-0622/0	W-1947/0
800001645	40	27	100	21	58	-	1	U-0622/0	W-1947/0
800001646	40	27	130	21	58	-	1	U-0622/0	W-1947/0
800001647	40	27	160	21	58	-	1	U-0622/0	W-1947/0
800001648	40	32	55	24	66	-	1	U-0623/0	W-1948/0
800001649	40	32	100	24	66	-	1	U-0623/0	W-1948/0
800001650	40	32	130	24	66	-	1	U-0623/0	W-1948/0
800001651	40	32	160	24	66	-	1	U-0623/0	W-1948/0
800001652	40	40	60	27	80	-	1	U-0624/0	W-1949/0
800001653	40	40	100	27	80	-	1	U-0624/0	W-1949/0
800001654	40	40	130	27	80	-	1	U-0624/0	W-1949/0
800001655	40	40	160	27	80	-	1	U-0624/0	W-1949/0
800001656	50	16	55	17	38	-	1	U-0620/0	W-1945/0
800001657	50	16	100	17	38	50	2*	U-0620/0	W-1945/0
800001658	50	16	130	17	38	50	2*	U-0620/0	W-1945/0
800001659	50	16	160	17	38	50	2*	U-0620/0	W-1945/0
800001660	50	16	200	17	38	50	2*	U-0620/0	W-1945/0
800001661	50	22	55	19	48	-	1	U-0621/0	W-1946/0
800001662	50	22	100	19	48	62	2*	U-0621/0	W-1946/0
800001663	50	22	130	19	48	62	2*	U-0621/0	W-1946/0
800001664	50	22	160	19	48	62	2*	U-0621/0	W-1946/0
800001665	50	22	200	19	58	62	2*	U-0621/0	W-1947/0
800001666	50	27	60	21	58	-	1	U-0622/0	W-1947/0
800001667	50	27	100	21	58	76	2*	U-0622/0	W-1947/0
800001668	50	27	130	21	58	76	2*	U-0622/0	W-1947/0
800001669	50	27	160	21	58	76	2*	U-0622/0	W-1947/0
800001670	50	27	200	21	58	76	2*	U-0622/0	W-1947/0
800001671	50	32	65	24	66	-	1	U-0623/0	W-1948/0
800001672	50	32	100	24	66	80	2*	U-0623/0	W-1948/0
800001673	50	32	130	24	66	80	2*	U-0623/0	W-1948/0
800001674	50	32	160	24	66	80	2*	U-0623/0	W-1948/0
800001675	50	32	200	24	66	80	2*	U-0623/0	W-1948/0
800001676	50	40	70	27	80	-	1	U-0624/0	W-1949/0
800001677	50	40	100	27	80	-	1	U-0624/0	W-1949/0
800001678	50	40	130	27	80	-	1	U-0624/0	W-1949/0
800001679	50	40	160	27	80	-	1	U-0624/0	W-1949/0
800001680	50	40	200	27	80	-	1	U-0624/0	W-1949/0
800001681	50	50	70	30	90	-	1	U-0625/0	U-5974/0
800001682	50	50	100	30	90	-	1	U-0625/0	U-5974/0
800001683	50	50	130	30	90	-	1	U-0625/0	U-5974/0
800001684	50	50	160	30	90	-	1	U-0625/0	U-5974/0
800001685	50	50	200	30	90	-	1	U-0625/0	U-5974/0

## 7388 AD+B

■ Frézařské trny pro frézy s příčnou unásečí drážkou

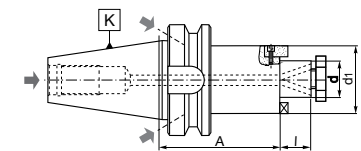

OBR.1

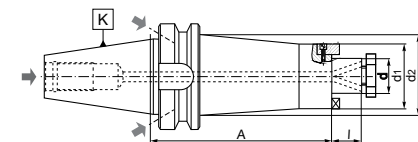

OBR.2

\* pro odpovídající tuhost vyrobeno s kuželem, verze válcová (d<sub>1</sub>=d<sub>2</sub>) je na poptávku

## 7388 A

■ Frézařské trny pro frézy s příčnou unášecí drážkou

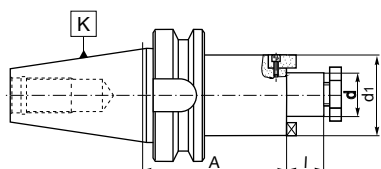

Kód výrobku	K 7:24	d	A	l	d <sub>1</sub>		
800001612	30	16	43	17	32	U-0620/0	S-2117/0
800001613	30	22	43	19	40	U-0621/0	S-2121/0
800001614	30	27	43	21	48	U-0622/0	S-2111/0
800001615	30	32	45	24	58	U-0623/0	S-2114/0
800001616	40	16	52	17	32	U-0620/0	S-2117/0
800001617	40	16	120	17	32	U-0620/0	S-2117/0
800001618	40	22	52	19	40	U-0621/0	S-2121/0
800001619	40	22	120	19	40	U-0621/0	S-2121/0
800001620	40	27	52	21	48	U-0622/0	S-2111/0
800001621	40	27	120	21	48	U-0622/0	S-2111/0
800001622	40	32	52	24	58	U-0623/0	S-2114/0
800001623	40	32	120	24	58	U-0623/0	S-2114/0
800001624	40	40	60	27	70	U-0624/0	S-2124/0
800001625	50	16	65	17	32	U-0620/0	S-2117/0
800001626	50	16	110	17	32	U-0620/0	S-2117/0
800001627	50	22	65	19	40	U-0621/0	S-2121/0
800001628	50	22	110	19	40	U-0621/0	S-2121/0
800001629	50	27	65	21	48	U-0622/0	S-2111/0
800001630	50	27	110	21	48	U-0622/0	S-2111/0
800001631	50	32	65	24	58	U-0623/0	S-2114/0
800001632	50	32	110	24	58	U-0623/0	S-2114/0
800001633	50	40	78	27	70	U-0624/0	S-2124/0
800001634	50	40	110	27	70	U-0624/0	S-2124/0
800001635	50	50	78	30	90	U-0625/0	U-5974/0

## 7361 A

■ Frézařské trny univerzální

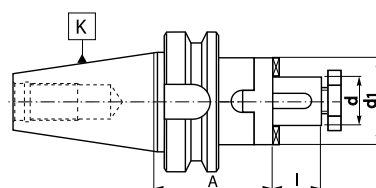

Kód výrobku	K 7:24	d	A	l	d <sub>1</sub>			
800001495	40	16	55	17	32	U-0620/0	U-1364/0	U-1355/0
800001496	40	22	55	19	40	U-0621/0	U-1365/0	U-1356/0
800001497	40	27	55	21	48	U-0622/0	U-1366/0	U-1357/0
800001498	40	32	60	24	58	U-0623/0	U-1367/0	U-6355/0
800001499	40	40	60	27	70	U-0624/0	U-1368/0	U-1359/0
800001500	50	16	70	17	32	U-0620/0	U-1364/0	U-1355/0
800001501	50	22	70	19	40	U-0621/0	U-1365/0	U-1356/0
800001502	50	27	70	21	48	U-0622/0	U-1366/0	U-1357/0
800001503	50	32	70	24	58	U-0623/0	U-1367/0	U-6355/0
800001504	50	40	70	27	70	U-0624/0	U-1368/0	U-1359/0
800001505	50	50	70	30	90	U-0625/0	U-1369/0	U-1360/0

## 7668 AD+B

■ Frézařské trny pro frézy se závitem

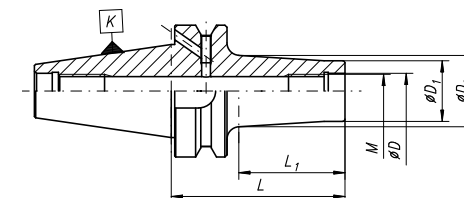

Kód výrobku	K 7:24	M	L	L1	D	D <sub>1</sub>	D <sub>2</sub>
800006869	40	M8	63	30	8,5	13	15
800006870	40	M8	83	50	8,5	13	23
800006871	40	M8	103	70	8,5	13	23
800006872	40	M8	123	90	8,5	13	25
800006873	40	M10	63	30	10,5	18	20
800006874	40	M10	83	50	10,5	18	25
800006875	40	M10	103	70	10,5	18	28
800006876	40	M10	123	90	10,5	18	28
800006877	40	M12	63	30	12,5	21	24
800006878	40	M12	83	50	12,5	21	24
800006879	40	M12	103	70	12,5	21	31
800006880	40	M12	123	90	12,5	21	31
800006881	40	M16	63	30	17	29	34
800006882	40	M16	83	50	17	29	34
800006883	40	M16	103	70	17	29	34
800006884	40	M16	123	92	17	29	39
800006885	40	M16	153	122	17	29	39
800006886	50	M12	104	60	12,5	21	39
800006887	50	M12	154	110	12,5	21	39
800006888	50	M16	104	60	17	29	36
800006889	50	M16	154	110	17	29	40

1  
2  
3  
4  
5  
6  
7

## 7372 A

■ Frézařské trny pro kotoučové frézy

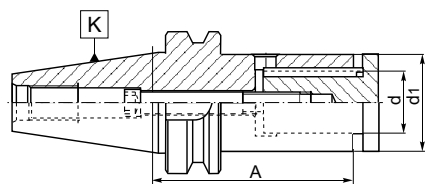

Kód výrobku	K 7:24	d	d <sub>1</sub>	A	Rozsah upínání			
800001580	40	16	29	95	0-10	U-6520/0	U-6510/0	U-6526/0
800001581	40	16	29	125	0-16	U-6520/0	U-6511/0	U-6527/0
800001582	40	22	36	95	0-10	U-6523/0	U-6512/0	U-6528/0
800001583	40	22	36	125	0-20	U-6523/0	U-6513/0	U-6529/0
800001584	40	27	42	95	0-10	U-6523/0	U-6514/0	U-6530/0
800001585	40	27	42	125	0-20	U-6523/0	U-6515/0	U-6531/0
800001586	40	32	50	95	0-10	U-6523/0	U-6516/0	U-6532/0
800001587	40	32	50	125	0-20	U-6523/0	U-6517/0	U-6533/0
800001588	50	22	36	100	0-10	U-6524/0	U-6512/0	U-6528/0
800001589	50	22	36	125	0-20	U-6524/0	U-6513/0	U-6529/0
800001590	50	27	42	100	0-10	U-6524/0	U-6514/0	U-6530/0
800001591	50	27	42	125	0-20	U-6524/0	U-6515/0	U-6531/0
800001592	50	32	50	100	0-10	U-6524/0	U-6516/0	U-6532/0
800001593	50	32	50	125	0-20	U-6524/0	U-6517/0	U-6533/0
800001594	50	40	58	100	0-10	U-6524/0	U-6518/0	U-6534/0
800001595	50	40	58	125	0-20	U-6524/0	U-6519/0	U-6535/0

## 2826 A

■ Frézařské trny pro frézovací hlavy

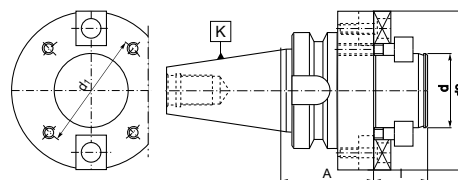

Kód výrobku	K 7:24	d	d <sub>1</sub>	d <sub>2</sub>	A	l		
800000596	40	40	66,7	89	60	30	U-6064/0	U-1414/0
800000597	40	60	101,6	129	60	40	U-6066/0	U-2042/0
800000598	50	40	66,7	89	70	30	U-6064/0	U-1414/0
800000599	50	60	101,6	129	80	40	U-6066/0	U-2042/0

## 1613 AD

■ Držáky s axiálním nastavením dle DIN 6327

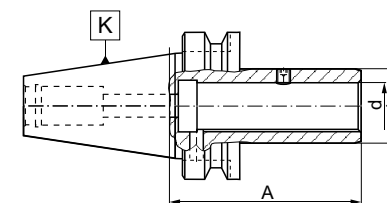

Kód výrobku	K 7:24	d	d <sub>1</sub>	A	
800000075	40	16	25	75	U-1997/0
800000076	40	20	32	80	U-1997/0
800000077	40	28	40	100	U-7381/0
800000078	40	36	50	115	U-7381/0
800000079	50	16	25	85	U-1997/0
800000080	50	20	32	85	U-1997/0
800000081	50	28	40	100	U-7381/0
800000082	50	36	50	100	U-7381/0
800000083	50	48	67	105	U-7382/0

## 7656 A

- Vrtací sklíčidlo samosvorné
- Klíč je součástí dodávky

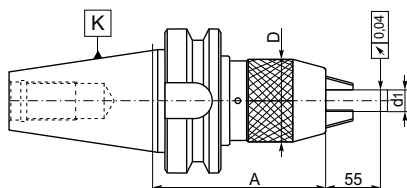

Kód výrobku	K 7:24	d <sub>1</sub>	A	D
800002394	40	1-13	95	50
800002395	40	3-16	100	57
800002396	50	1-13	105	50
800002397	50	3-16	110	57

## 7661 A

- Vrtací sklíčidlo pro pravé i levé otáčky upínané "inbus" klíčem
- Klíč je součástí dodávky

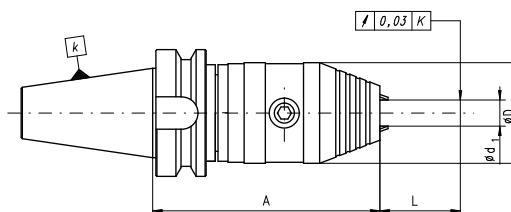

Kód výrobku	K 7:24	d <sub>1</sub>	Upínací moment	A	D
800006589	40	1-13	40Nm	113	50
800006590	40	3-16	45Nm	113	50
800006591	50	1-13	40Nm	124	50
800006592	50	3-16	45Nm	124	50

## 1661 AD

- Univerzální redukční pouzdra pro nástroje se stopkou Morse se závitem nebo unašečem

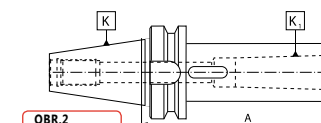
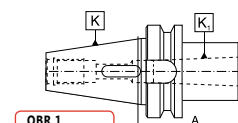

\* pouze pro nástroje s kuzelem Morse dle DIN 228-B

Kód výrobku	K 7:24	K <sub>1</sub> MK	A	d <sub>1</sub>	Obr.
800000126	30	1	50	25	1
800000127	30	2*	60	32	1
800000128	30	3*	79	40	1
800000129	40	1	50	25	1
800000131	40	2	50	32	1
800000133	40	3*	70	40	1
800000135	40	4*	95	48	1
800000130	40	1	120	25	2
800000132	40	2	120	32	2
800000134	40	3*	135	40	2
800000136	40	4*	165	48	2
800000137	50	1	45	25	1
800000139	50	2	60	32	1
800000141	50	3	65	40	1
800000143	50	4	95	48	1
800000145	50	5*	105	63	1
800000138	50	1	120	25	2
800000140	50	2	135	32	2
800000142	50	3	155	40	2
800000144	50	4	180	48	2
800000146	50	5*	215	63	2

1  
2  
3  
4  
5  
6  
7



### 1694 AD

- Redukční pouzdra pro nástroje s kuželem Morse se závitem

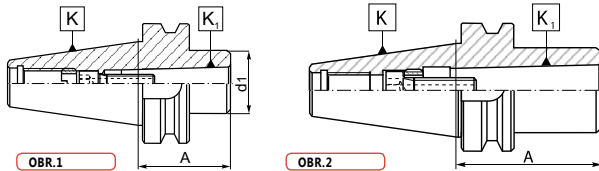

Kód výrobku	K 7:24	K <sub>1</sub> MK	A	d <sub>1</sub>	Obr.	
80000247	30	1	50	25	1	W-1091/0
80000248	30	2	62	32	2	W-1095/0
80000249	30	3	82	40	2	U-7790/0
80000250	40	1	50	25	1	W-1091/0
80000251	40	2	50	32	1	W-1092/0
80000252	40	3	70	40	2	W-1093/0
80000253	40	4	95	48	2	W-1094/0
80000254	50	1	45	25	1	W-1091/0
80000255	50	2	60	32	1	W-1095/0
80000256	50	3	65	40	1	W-1096/0
80000257	50	4	90	48	1	W-1097/0
80000258	50	5	120	63	2	W-1098/0

### 1661 AD+B

- Univerzální redukční pouzdra pro nástroje se stopkou Morse se závitem nebo unašečem

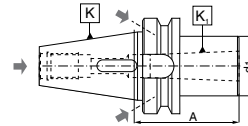



\* pouze pro nástroje s kuželem Morse dle DIN 228-B

Kód výrobku	K 7:24	K <sub>1</sub> MK	A	d <sub>1</sub>
80000147	40	2	50	32
80000148	40	3*	70	40
80000149	40	4*	95	48
80000150	50	2	60	32
80000151	50	3	65	40
80000152	50	4	95	48
80000153	50	5*	120	63

### 1663 A

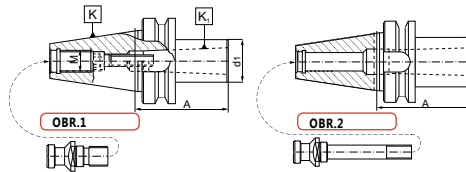
- Redukční pouzdra pro nástroje s kuželem Morse se závitem
- Varianta dle obrázku č. 2 vyžaduje speciální dlouhý upínací čep typu 9883



Kód výrobku	K 7:24	K <sub>1</sub> MK	A	d <sub>1</sub>	M	Obr.	
80000154	30	1	45	25	M12	1	W-1348/0
80000155	30	2	60	32	—	2	—
80000156	40	1	45	25	M16	1	W-1091/0
80000157	40	2	60	32	M16	1	W-1092/0
80000158	40	3	75	40	—	2	—
80000159	40	4	85	48	—	2	—
80000160	50	1	45	25	M24	1	W-1091/0
80000161	50	2	45	32	M24	1	W-1095/0
80000162	50	3	60	40	M24	1	W-1096/0
80000163	50	4	75	48	M24	1	U-5984/0
80000164	50	5	75	63	—	2	—

### 1694 AD+B

- Redukční pouzdra pro nástroje s kuželem Morse se závitem

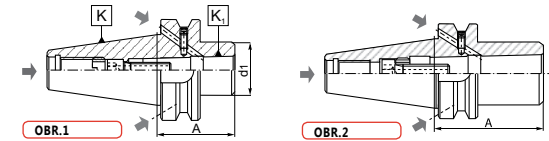

Kód výrobku	K 7:24	K <sub>1</sub> MK	A	d <sub>1</sub>	Obr.	
80000259	40	2	50	32	1	W-1092/0
80000260	40	3	70	40	2	W-1093/0
80000261	40	4	95	48	2	W-1094/0
80000262	50	2	60	32	1	W-1095/0
80000263	50	3	65	40	1	W-1096/0
80000264	50	4	95	48	1	W-1097/0
80000265	50	5	120	63	2	W-1098/0

### 1660 AD

- Redukční pouzdra pro nástroje s kuželem 7:24

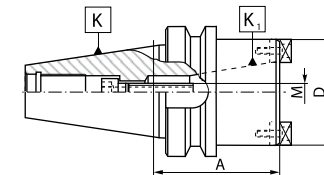

Kód výrobku	K 7:24	K <sub>1</sub> 7:24	A	D	M	
80000125	50	40	80	88	M16	U-6227/0

## 7632 AD

- Tepelné upínače
- Vhodné pro HSS a tvrdokovové nástroje s válcovou stopkou (tolerance h6)
- Max. házivost = 0,003mm
- Max. ohřivací teplota 500°C
- Provedení s úhlem 3° je dostupné na objednávku

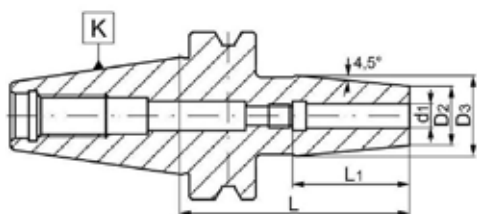

\* Provedení 3° - na objednávku!

Kód výrobku	K 7:24	d <sub>1</sub>	L	L <sub>1</sub>	D <sub>2</sub>	D <sub>3</sub>
800006402	40	3	80	36	14	22
800006403	40	3	120	36	14	22
800006404	40	3	160	36	14	22
800006405	40	4	80	36	14	22
800006406	40	4	120	36	14	22
800006407	40	4	160	36	14	22
800006408	40	5	80	36	16	22
800006409	40	5	120	36	16	22
800006410	40	5	160	36	16	22
800006411	40	6	90	36	21	27
800006412	40	6	120	36	21	27
800006413	40	6	160	36	21	27
800006414	40	8	90	36	21	27
800006415	40	8	120	36	21	27
800006416	40	8	160	36	21	27
800006417	40	10	90	42	24	32
800006418	40	10	120	42	24	32
800006419	40	10	160	42	24	32
800006420	40	12	90	47	24	32
800006421	40	12	120	47	24	32
800006422	40	12	160	47	24	32
800006423	40	14	90	47	27	34
800006424	40	14	120	47	27	34
800006425	40	14	160	47	27	34
800006426	40	16	90	50	27	34
800006427	40	16	120	50	27	34
800006428	40	16	160	50	27	34
800006429	40	18	90	50	33	42
800006430	40	18	120	50	33	42
800006431	40	18	160	50	33	42
800006432	40	20	90	52	33	42
800006433	40	20	120	52	33	42
800006434	40	20	160	52	33	42
800006435	40	25	100	58	44	53
800006436	40	25	120	58	44	53
800006437	40	25	160	58	44	53
800006438	40	32	100	58	44	53

Kód výrobku	K 7:24	d <sub>1</sub>	L	L <sub>1</sub>	D <sub>2</sub>	D <sub>3</sub>
800006439	50	6	100	36	21	27
800006440	50	8	100	36	21	27
800006441	50	10	100	42	24	32
800006442	50	12	100	47	24	32
800006443	50	14	100	47	27	34
800006444	50	16	100	50	27	34
800006445	50	18	100	50	33	42
800006446	50	20	100	52	33	42
800006447	50	25	110	58	44	53
800006448	50	32	110	58	44	53

■ Jiné rozměry jsou na poptávku

1

2

3

4

5

6

7

**2192 A**

■ Polotovary

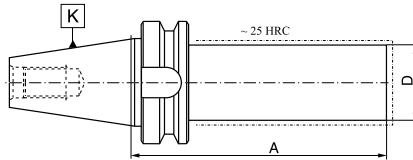

Kód výrobku	K 7:24	D	A
800000579	40	40	280
800000582	40	63	280
800000584	50	50	330
800000585	50	80	330

**2854**

■ Kontrolní trny

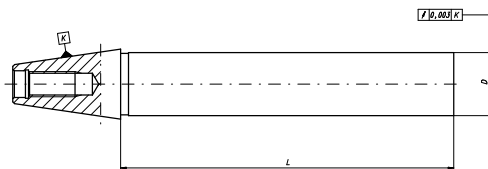

Kód výrobku	K 7:24	D	L
800006694	40	40	300
800006695	50	50	300

**9883 A**

■ Upínací čepy MAS 403-BT - průchozí

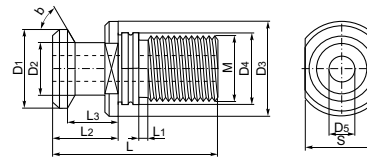
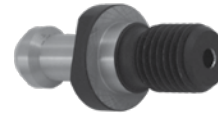

\* Velikost

Kód výrobku	W*	L	b	M	L1	L2	L3	D1	D2	D3	D4	D5	S
800003007	40	60	45°	M16	4	35	28	15	10	23	17	4	19
800003008	40	60	60°	M16	4	35	28	15	10	23	17	4	19
800003009	40	60	90°	M16	4	35	28	15	10	23	17	4	19
800003010	50	85	45°	M24	8	45	35	23	17	38	25	6	30
800003011	50	85	60°	M24	8	45	35	23	17	38	25	6	30
800003012	50	85	90°	M24	8	45	35	23	17	38	25	6	30

**9883 B**

■ Upínací čepy MAS 403-BT - neprůchozí

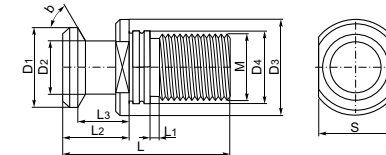
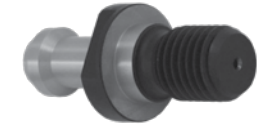

\* Velikost

Kód výrobku	W*	L	b	M	L1	L2	L3	D1	D2	D3	D4	S
800003508	30	43	45°	M12	2	23	18	11	7	16,5	12,5	13
800003509	30	43	60°	M12	2	23	18	11	7	16,5	12,5	13
800003013	40	60	45°	M16	4	35	28	15	10	23	17	19
800003014	40	60	60°	M16	4	35	28	15	10	23	17	19
800003015	40	60	90°	M16	4	35	28	15	10	23	17	19
800003016	40	120	45°	M12	64	35	28	15	10	23	17	19
800003017	40	120	60°	M12	64	35	28	15	10	23	17	19
800003018	40	120	90°	M12	64	35	28	15	10	23	17	19
800003019	40	125	45°	M16	69	35	28	15	10	23	17	19
800003020	40	125	60°	M16	69	35	28	15	10	23	17	19
800003021	40	125	90°	M16	69	35	28	15	10	23	17	19
800003022	50	85	45°	M24	8	45	35	23	17	38	25	30
800003023	50	85	60°	M24	8	45	35	23	17	38	25	30
800003024	50	85	90°	M24	8	45	35	23	17	38	25	30
800003025	50	125	45°	M24	48	45	35	23	17	38	25	30
800003026	50	125	60°	M24	48	45	35	23	17	38	25	30
800003027	50	125	90°	M24	48	45	35	23	17	38	25	30

## DIN 2080

- Materiál: legovaná ocel chrom-manganová
- Cementováno do hloubky 0,7mm
- Kaleno a přesně broušeno
- Tvrdost povrchů 58±2 HRC
- Tolerance úhlu kuželu AT3

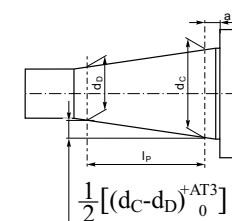
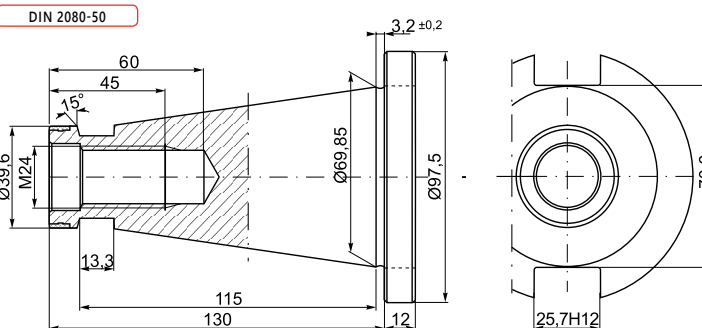
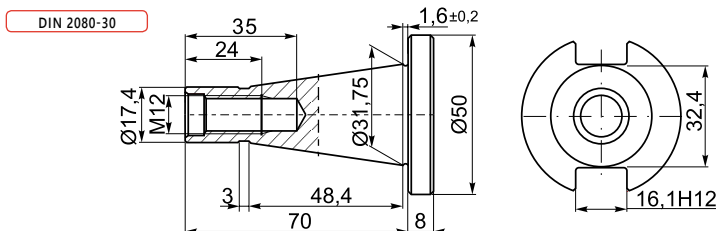
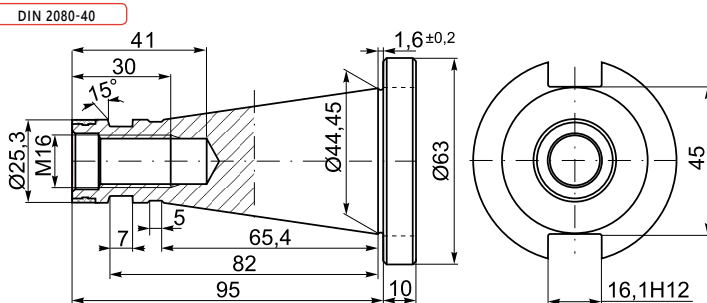

K 7:24	d <sub>c</sub> -d <sub>b</sub>	l <sub>p</sub>	a	AT3
30	12,250	42	1,6	0,002
40	17,208	59	1,6	0,003
50	26,833	92	3,2	0,004

$$\frac{1}{2} [(d_c - d_b)_{0}^{+AT3}]$$

## 7616

- Kleštinové upínače pro kleštiny ER (DIN 6499)

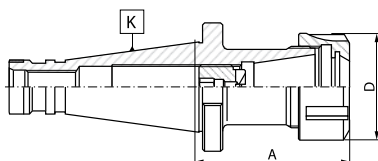

Kód výrobku	K 7:24	Kleštiny	A	Rozsah upínání	D		
800001754	30	ER16	50	2-10	32	9833-16	M10x11LH
800001755	30	ER32	50	2-20	50	9833-32	M18x1,5x19LH
800001756	40	ER25	60	2-16	42	9833-25	M18x1,5x19LH
800001757	40	ER32	60	2-20	50	9833-32	M22x1,5x24LH
800001758	40	ER32	130	2-20	50	9833-32	M22x1,5x24LH
800001759	40	ER40	60	2-26	63	9833-40	M28x1,5x30LH
800001760	50	ER32	70	2-20	50	9833-32	M22x1,5x24LH
800001761	50	ER32	130	2-20	50	9833-32	M22x1,5x24LH
800001762	50	ER40	70	2-26	63	9833-40	M28x1,5x30LH
800001763	50	ER40	130	2-26	63	9833-40	M28x1,5x30LH

## 7616-S

- Kleštinové upínače pro kleštiny ER (DIN 6499) prodoužené

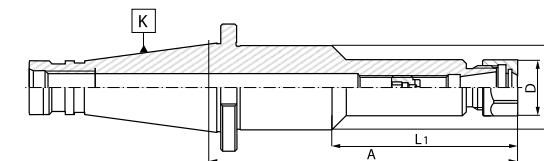

Kód výrobku	K 7:24	Kleštiny	A	Rozsah upínání	L <sub>1</sub>	D	D <sub>1</sub>		
800001764	40	ER16	100	2-10	-	28	-	9833-16D	M12x1,5x14LH
800001765	40	ER16	150	2-10	85	28	40	9833-16D	M12x1,5x14LH
800001766	50	ER16	100	2-10	-	28	-	9833-16D	M12x1,5x14LH
800001767	50	ER16	150	2-10	85	28	40	9833-16D	M12x1,5x14LH

1  
2  
3  
4  
5  
6  
7

**7616-KPL**
**7616-PL**
**7616-S PL**

■ Kleštinové upínače pro kleštiny ER (DIN 6499) se sadou kleštín



Kód výrobku	K 7:24	Kleština	A	Rozsah upínání	Počet kleštín v sadě
<b>7616</b>					
800001768	30	ER16	50	2-10	8
800001769	30	ER32	50	2-20	18
800001770	40	ER25	60	2-16	14
800001771	40	ER32	60	2-20	18
800001772	40	ER32	130	2-20	18
800001773	40	ER40	60	2-26	24
800001774	50	ER32	70	2-20	18
800001775	50	ER32	130	2-20	18
800001776	50	ER40	70	2-26	24
<b>7616-PL</b>					
800001781	30	ER32	50	3-20	8
800001782	40	ER32	60	3-20	8
800001783	50	ER32	70	3-20	8
<b>7616-S PL</b>					
800001777	40	ER16	100	2-10	8
800001778	40	ER16	150	2-10	8
800001779	50	ER16	100	2-10	8
800001780	50	ER16	150	2-10	8

**7620**

■ Frézařské trny pro nástroje s válcovou stopkou dle DIN 1835-B (WELDON)

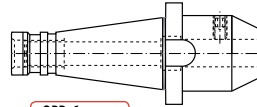

OBR. 1

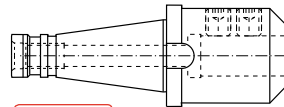

OBR. 2

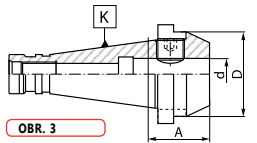

OBR. 3

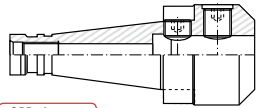

OBR. 4

Kód výrobku	K 7:24	d	A	D	Obr.	
800001910	30	6	40	25	1	U-4131/0
800001911	30	8	40	28	1	U-4132/0
800001912	30	10	40	35	1	U-4133/0
800001913	30	12	40	42	1	U-4134/0
800001914	30	16	50	48	1	U-4135/0
800001915	30	20	63	52	1	U-4136/0
800001916	30	25	68	63	2	U-4137/0
800001917	40	6	25	25	3	U-4131/0
800001918	40	6	50	25	1	U-4131/0
800001919	40	8	25	28	3	U-4132/0
800001920	40	8	50	28	1	U-4132/0
800001921	40	10	27	35	3	U-4133/0
800001922	40	10	50	35	1	U-4133/0
800001923	40	12	29	42	3	U-4134/0
800001924	40	12	50	42	1	U-4134/0
800001925	40	14	30	44	3	U-4134/0
800001926	40	14	50	44	1	U-4134/0
800001927	40	16	31	44	3	U-5887/0
800001928	40	16	63	48	1	U-4135/0
800001929	40	18	63	50	1	U-4135/0
800001930	40	20	35	52	3	U-6756/0
800001931	40	20	63	52	1	U-4136/0
800001932	40	25	60	65	4	U-6756/0 + U-4137/0
800001933	40	25	80	63	2	2x U-4137/0
800001934	40	32	70	72	2	2x U-4138/0
800001935	40	32	80	72	2	2x U-4138/0
800001936	40	32	100	72	2	2x U-4138/0
800001937	50	6	63	25	1	U-4131/0
800001938	50	6	130	25	1	U-4131/0
800001939	50	8	63	28	1	U-4132/0
800001940	50	8	130	28	1	U-4132/0
800001941	50	10	63	35	1	U-4133/0
800001942	50	10	130	35	1	U-4133/0
800001943	50	12	63	42	1	U-4134/0
800001944	50	12	130	42	1	U-4134/0
800001945	50	14	63	44	1	U-4135/0
800001946	50	16	63	48	1	U-4135/0
800001947	50	16	130	48	1	U-4135/0
800001948	50	16	160	48	1	U-4135/0
800001949	50	16	200	48	1	U-4135/0
800001950	50	18	63	50	1	U-4135/0
800001951	50	20	36	52	3	U-4136/0
800001952	50	20	63	52	1	U-4136/0
800001953	50	20	130	52	1	U-4136/0
800001954	50	25	60	65	4	2x U-4137/0
800001955	50	25	80	65	2	2x U-4137/0
800001956	50	25	130	65	2	2x U-4137/0
800001957	50	25	160	65	2	2x U-4137/0
800001958	50	32	70	70	4	2x U-4138/0
800001959	50	32	81	70	2	2x U-4138/0
800001960	50	32	100	70	2	2x U-4138/0
800001961	50	32	130	72	2	2x U-4138/0
800001962	50	32	160	72	2	2x U-4138/0
800001963	50	40	91	90	2	2x U-4138/0
800001964	50	40	100	90	2	2x U-4138/0
800001965	50	50	110	97	2	2x U-4139/0
800001966	50	63	115	97	2	2x U-4139/0

**7627**

■ Frézařské trny pro nástroje s válcovou stopkou dle DIN 1835-E (Whistle-Notch)

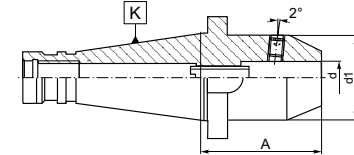

OBR. 1

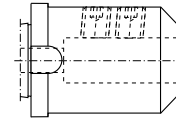



OBR. 2

Kód výrobku	K 7:24	d	d <sub>1</sub>	A	Obr.		
800002327	40	6	25	50	1	U-4131/0	U-1599/0
800002328	40	8	28	50	1	U-4132/0	U-6317/0
800002329	40	10	35	50	1	U-4133/0	U-0293/0
800002330	40	12	42	50	1	U-4134/0	U-0757/0
800002331	40	14	44	50	1	U-4134/0	U-6318/0
800002332	40	16	48	63	1	U-4135/0	U-6318/0
800002333	40	18	50	63	1	U-4136/0	U-6793/0
800002334	40	20	52	63	1	U-4136/0	U-6793/0
800002335	40	25	65	80	2	2x U-4137/0	U-6794/0
800002336	40	32	72	80	2	2x U-4138/0	U-6794/0
800002337	50	6	25	63	1	U-4131/0	U-1599/0
800002338	50	8	28	63	1	U-4132/0	U-6317/0
800002339	50	10	35	63	1	U-4133/0	U-0293/0
800002340	50	12	42	63	1	U-4134/0	U-0757/0
800002341	50	14	44	63	1	U-4135/0	U-6318/0
800002342	50	16	48	63	1	U-4135/0	U-6318/0
800002343	50	18	50	63	1	U-4136/0	U-6793/0
800002344	50	20	52	63	1	U-4136/0	U-6793/0
800002345	50	25	65	80	2	2x U-4137/0	U-6794/0
800002346	50	32	72	80	2	2x U-4138/0	U-6794/0
800002347	50	40	90	90	2	2x U-5870/0	U-6794/0

## 7311

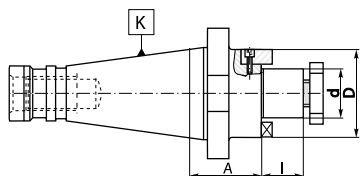
■ Frézařské trny pro frézy s příčnou unášecí drážkou





Kód výrobku	K 7:24	d	A	I	D		
800001385	30	16	35	17	32	U-0620/0	S-2117/0
800001386	30	22	35	19	40	U-0621/0	S-2121/0
800001387	30	27	35	21	48	U-0622/0	S-2111/0
800001388	30	32	35	24	58	U-0623/0	S-2114/0
800001389	40	16	37	17	32	U-0620/0	S-2117/0
800001390	40	16	90	17	32	U-0620/0	S-2117/0
800001391	40	22	37	19	40	U-0621/0	S-2121/0
800001392	40	22	90	19	40	U-0621/0	S-2121/0
800001393	40	27	37	21	48	U-0622/0	S-2111/0
800001394	40	27	90	21	48	U-0622/0	S-2111/0
800001395	40	32	37	24	58	U-0623/0	S-2114/0
800001396	40	32	90	24	58	U-0623/0	S-2114/0
800001397	40	40	37	27	70	U-0624/0	S-2124/0
800001398	40	40	90	27	70	U-0624/0	S-2124/0
800001399	50	22	40	19	40	U-0621/0	S-2121/0
800001400	50	22	100	19	40	U-0621/0	S-2121/0
800001401	50	27	40	21	48	U-0622/0	S-2111/0
800001402	50	27	100	21	48	U-0622/0	S-2111/0
800001403	50	32	40	24	58	U-0623/0	S-2114/0
800001404	50	32	100	24	58	U-0623/0	S-2114/0
800001405	50	40	40	27	70	U-0624/0	S-2124/0
800001406	50	40	100	27	70	U-0624/0	S-2124/0
800001407	50	50	40	30	90	U-0625/0	U-5974/0
800001408	50	50	100	30	90	U-0625/0	U-5974/0

## 7332

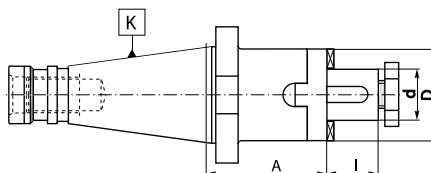
■ Frézařské trny univerzální



Kód výrobku	K 7:24	d	A	I	D			
800001439	30	16	35	17	32	U-0620/0	U-1364/0	U-1355/0
800001440	30	16	50	17	32	U-0620/0	U-1364/0	U-1355/0
800001441	30	16	73	17	32	U-0620/0	U-1364/0	U-1355/0
800001442	30	22	35	19	40	U-0621/0	U-1365/0	U-1356/0
800001443	30	22	50	19	40	U-0621/0	U-1365/0	U-1356/0
800001444	30	22	73	19	40	U-0621/0	U-1365/0	U-1356/0
800001445	30	27	35	21	48	U-0622/0	U-1366/0	U-1357/0
800001446	30	27	50	21	48	U-0622/0	U-1366/0	U-1357/0
800001447	30	27	73	21	48	U-0622/0	U-1366/0	U-1357/0
800001448	30	32	50	24	58	U-0623/0	U-1367/0	U-1358/0
800001449	40	16	37	17	32	U-0620/0	U-1364/0	U-1355/0
800001450	40	16	52	17	32	U-0620/0	U-1364/0	U-1355/0
800001451	40	16	75	17	32	U-0620/0	U-1364/0	U-1355/0
800001452	40	22	37	19	40	U-0621/0	U-1365/0	U-1356/0
800001453	40	22	52	19	40	U-0621/0	U-1365/0	U-1356/0
800001454	40	22	75	19	40	U-0621/0	U-1365/0	U-1356/0
800001455	40	27	37	21	48	U-0622/0	U-1366/0	U-1357/0
800001456	40	27	52	21	48	U-0622/0	U-1366/0	U-1357/0
800001457	40	27	75	21	48	U-0622/0	U-1366/0	U-1357/0
800001458	40	32	41	24	58	U-0623/0	U-1367/0	U-1358/0
800001459	40	32	52	24	58	U-0623/0	U-1367/0	U-1358/0
800001460	40	32	75	24	58	U-0623/0	U-1367/0	U-1358/0
800001461	40	40	45	27	70	U-0624/0	U-1368/0	U-1359/0
800001462	40	40	52	27	70	U-0624/0	U-1368/0	U-1359/0
800001463	40	40	75	27	70	U-0624/0	U-1368/0	U-1359/0
800001464	50	16	55	17	32	U-0620/0	U-1364/0	U-1355/0
800001465	50	16	78	17	32	U-0620/0	U-1364/0	U-1355/0
800001466	50	22	55	19	40	U-0621/0	U-1365/0	U-1356/0
800001467	50	22	78	19	40	U-0621/0	U-1365/0	U-1356/0
800001468	50	27	55	21	48	U-0622/0	U-1366/0	U-1357/0
800001469	50	27	78	21	48	U-0622/0	U-1366/0	U-1357/0
800001470	50	32	55	24	58	U-0623/0	U-1367/0	U-1358/0
800001471	50	32	78	24	58	U-0623/0	U-1367/0	U-1358/0
800001472	50	40	55	27	70	U-0624/0	U-1368/0	U-1359/0
800001473	50	40	78	27	70	U-0624/0	U-1368/0	U-1359/0
800001474	50	50	55	30	90	U-0625/0	U-1369/0	U-1360/0
800001475	50	50	78	30	90	U-0625/0	U-1369/0	U-1360/0

1

2

3

4

5

6

7

## 7314

■ Frézařské trny pro kotoučové frézy

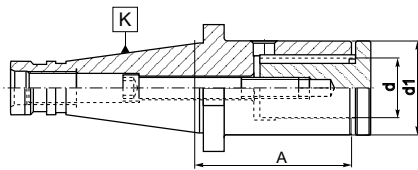

Kód výrobku	K 7:24	d	d <sub>1</sub>	A	Rozsah upínání			
800001423	40	16	29	70	0-10	U-6520/0	U-6510/0	U-6526/0
800001424	40	16	29	100	0-16	U-6520/0	U-6511/0	U-6527/0
800001425	40	22	36	70	0-10	U-6523/0	U-6512/0	U-6528/0
800001426	40	22	36	100	0-20	U-6523/0	U-6513/0	U-6529/0
800001427	40	27	42	70	0-10	U-6523/0	U-6514/0	U-6530/0
800001428	40	27	42	100	0-20	U-6523/0	U-6515/0	U-6531/0
800001429	40	32	50	70	0-10	U-6523/0	U-6516/0	U-6532/0
800001430	40	32	50	100	0-20	U-6523/0	U-6517/0	U-6533/0
800001431	40	40	58	70	0-10	U-6523/0	U-6518/0	U-6534/0
800001432	40	40	58	100	0-20	U-6523/0	U-6519/0	U-6535/0
800001433	50	27	42	75	0-10	U-6524/0	U-6514/0	U-6530/0
800001434	50	27	42	105	0-20	U-6524/0	U-6515/0	U-6531/0
800001435	50	32	50	75	0-10	U-6524/0	U-6516/0	U-6532/0
800001436	50	32	50	105	0-20	U-6524/0	U-6517/0	U-6533/0
800001437	50	40	58	75	0-10	U-6524/0	U-6518/0	U-6534/0
800001438	50	40	58	105	0-20	U-6524/0	U-6519/0	U-6535/0

## 2824

■ Frézařské trny pro frézovací hlavy

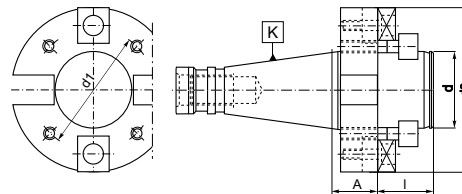

Kód výrobku	K 7:24	d	d <sub>1</sub>	d <sub>2</sub>	A	I		
800000590	40	40	66	89	30	30	U-6064/0	U-1414/0
800000591	40	50	101	129	30	40	U-6065/0	U-2042/0
800000592	40	60	101	129	30	40	U-6066/0	U-2042/0
800000593	50	40	66	89	30	30	U-6064/0	U-1414/0
800000594	50	50	101	129	30	40	U-6065/0	U-2042/0
800000595	50	60	101	129	30	40	U-6066/0	U-2042/0

## 1616

■ Držáky s axiálním nastavením dle DIN 6327

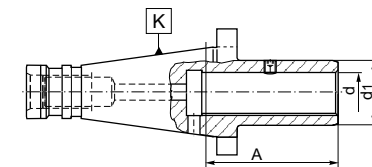

Kód výrobku	K 7:24	d	d <sub>1</sub>	A	
800000084	40	16	25	60	U-1997/0
800000085	40	20	32	60	U-1997/0
800000086	40	28	40	100	U-7381/0
800000087	40	36	50	120	U-7381/0
800000088	50	16	25	60	U-1997/0
800000089	50	20	32	60	U-1997/0
800000090	50	28	40	100	U-7381/0
800000091	50	36	50	100	U-7381/0
800000092	50	48	67	100	U-7382/0

# 7175

■ Dlouhé frézařské trny

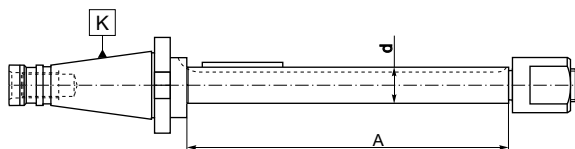

Kód výrobku	K 7:24	d	A		
800000914	30	16	200	4x4x45	M16x1,5
800000915	30	16	250	4x4x45	M16x1,5
800000916	30	16	315	4x4x45	M16x1,5
800000917	30	22	200	6x6x50	M20x2
800000918	30	22	250	6x6x50	M20x2
800000919	30	22	315	6x6x50	M20x2
800000920	30	22	400	6x6x50	M20x2
800000921	30	27	200	7x7x50	M24x2
800000922	30	27	250	7x7x50	M24x2

Kód výrobku	K 7:24	d	A		
800000923	30	27	315	7x7x50	M24x2
800000924	30	27	400	7x7x50	M24x2
800000925	40	16	200	4x4x45	M16x1,5
800000926	40	16	250	4x4x45	M16x1,5
800000927	40	16	315	4x4x45	M16x1,5
800000928	40	16	400	4x4x45	M16x1,5
800000929	40	22	200	6x6x50	M20x2
800000930	40	22	250	6x6x50	M20x2
800000931	40	22	315	6x6x50	M20x2
800000932	40	22	400	6x6x50	M20x2
800000933	40	22	500	6x6x50	M20x2
800000934	40	27	200	7x7x50	M24x2
800000935	40	27	250	7x7x50	M24x2
800000936	40	27	315	7x7x50	M24x2
800000937	40	27	400	7x7x50	M24x2
800000938	40	27	500	7x7x50	M24x2
800000939	40	27	630	7x7x50	M24x2
800000940	40	32	160	8x7x63	M27x2
800000941	40	32	250	8x7x63	M27x2
800000942	40	32	315	8x7x63	M27x2
800000943	40	32	400	8x7x63	M27x2
800000944	40	32	500	8x7x63	M27x2
800000945	40	32	630	8x7x63	M27x2
800000946	40	40	315	10x8x63	M33x2
800000947	40	40	400	10x8x63	M33x2
800000948	40	40	500	10x8x63	M33x2
800000949	40	40	630	10x8x63	M33x2
800000950	50	22	200	6x6x50	M20x2
800000951	50	22	250	6x6x50	M20x2
800000952	50	22	315	6x6x50	M20x2

Kód výrobku	K 7:24	d	A		
800000953	50	22	400	6x6x50	M20x2
800000954	50	22	500	6x6x50	M20x2
800000955	50	22	630	6x6x50	M20x2
800000956	50	27	315	7x7x50	M24x2
800000957	50	27	400	7x7x50	M24x2
800000958	50	27	500	7x7x50	M24x2
800000959	50	27	630	7x7x50	M24x2
800000960	50	27	800	7x7x50	M24x2
800000961	50	32	315	8x7x63	M27x2
800000962	50	32	400	8x7x63	M27x2
800000963	50	32	500	8x7x63	M27x2
800000964	50	32	630	8x7x63	M27x2
800000965	50	32	800	8x7x63	M27x2
800000966	50	32	900	8x7x63	M27x2
800003425	50	32	1000	8x7x63	M27x2
800000968	50	40	400	10x8x63	M33x3
800000969	50	40	500	10x8x63	M33x3
800000970	50	40	630	10x8x63	M33x3
800000971	50	40	800	10x8x63	M33x3
800000972	50	40	900	10x8x63	M33x3
800000967	50	40	1000	10x8x63	M33x3
800000974	50	50	400	12x8x80	M39x3
800000975	50	50	500	12x8x80	M39x3
800000976	50	50	630	12x8x80	M39x3
800000977	50	50	800	12x8x80	M39x3
800000978	50	50	900	12x8x80	M39x3
800000973	50	50	1000	12x8x80	M39x3
800000979	50	60	630	14x9x80	M45x3
800000980	50	60	800	14x9x80	M45x3
800000981	50	60	900	14x9x80	M45x3
800000982	50	60	1000	14x9x80	M45x3

# 7178

■ Dlouhé frézařské trny

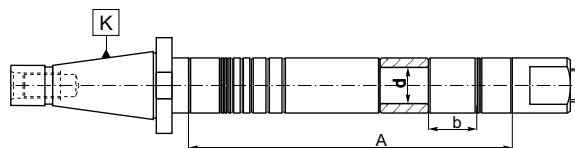

Kód výrobku	K 7:24	d	A	Kroužky - šířka kroužku/ počet na jeden trn										
				1	2	3	6	10	20	30	60	100		
800000983	30	16	200	2	3	4	2	4	2	3	-	-	-	-
800000984	30	16	250	2	3	4	2	4	3	4	-	-	-	-
800000985	30	16	315	1	4	2	2	4	5	5	-	-	-	-
800000986	30	22	200	1	3	1	2	2	2	2	1	-	-	-
800000987	30	22	250	1	3	1	2	1	2	2	2	-	-	-
800000988	30	22	315	1	4	2	2	2	3	3	2	-	-	-
800000989	30	22	400	1	3	1	2	3	4	3	3	-	-	-
800000990	30	27	200	1	3	1	2	2	2	2	1	-	-	-
800000991	30	27	250	1	3	1	2	1	2	2	2	-	-	-
800000992	30	27	315	1	4	2	2	2	3	3	2	-	-	-

Kód výrobku	K 7:24	d	A	Kroužky - šířka kroužku/ počet na jeden trn										
				1	2	3	6	10	20	30	60	100		
800000993	30	27	400	1	3	1	2	1	3	3	2	1	-	-
800000994	40	16	200	2	3	4	2	4	2	3	-	-	-	-
800000995	40	16	250	2	3	4	2	4	3	4	-	-	-	-
800000996	40	16	315	1	4	2	2	4	5	5	-	-	-	-
800000997	40	16	400	1	5	3	2	4	6	7	-	-	-	-
800000998	40	22	200	1	3	1	2	2	2	2	1	-	-	-
800000999	40	22	250	1	3	1	2	1	2	2	2	-	-	-
800001000	40	22	315	1	4	2	2	2	3	3	2	-	-	-
800001001	40	22	400	1	3	1	2	3	4	3	3	-	-	-
800001002	40	22	500	2	3	2	3	3	4	4	4	-	-	-
800001003	40	27	200	1	3	1	2	2	2	2	1	-	-	-
800001004	40	27	250	1	3	1	2	1	2	2	2	-	-	-
800001005	40	27	315	1	4	2	2	2	3	3	2	-	-	-
800001006	40	27	400	1	3	1	2	1	3	3	2	1	-	-
800001007	40	27	500	2	3	2	3	2	3	2	2	1	-	-
800001008	40	27	630	2	3	2	3	2	2	2	3	3	-	-
800001009	40	32	160	2	3	4	2	3	2	2	-	-	-	-
800001010	40	32	250	1	3	1	2	1	2	2	2	-	-	-
800001011	40	32	315	1	4	2	2	2	3	3	2	-	-	-
800001012	40	32	400	1	3	1	2	1	3	3	2	1	-	-
800001013	40	32	500	2	3	2	3	2	2	3	2	2	-	-
800001014	40	32	630	2	3	2	3	2	2	2	3	3	-	-
800001015	40	40	315	1	4	2	2	2	3	3	2	-	-	-
800001016	40	40	400	1	3	1	2	1	3	3	2	1	-	-
800001017	40	40	500	2	3	2	3	2	2	3	2	2	-	-
800001018	40	40	630	2	3	2	3	2	2	2	3	3	-	-
800001019	50	22	200	1	3	1	2	2	2	2	1	-	-	-
800001020	50	22	250	1	3	1	2	1	2	2	2	-	-	-
800001021	50	22	315	1	4	2	2	2	3	3	2	-	-	-
800001022	50	22	400	1	3	1	2	2	3	4	3	3	-	-

Kód výrobku	K 7:24	d	A	Kroužky - šířka kroužku/ počet na jeden trn										
				1	2	3	6	10	20	30	60	100		
800001023	50	22	500	2	3	2	3	2	3	4	4	-	-	-
800001024	50	22	630	2	3	2	3	3	4	4	4	-	-	-
800001025	50	27	315	1	4	2	2	2	3	3	2	-	-	-
800001026	50	27	400	1	3	1	2	1	3	3	2	1	-	-
800001027	50	27	500	2	3	2	3	2	2	3	2	2	-	-
800001028	50	27	630	2	3	2	3	2	2	2	3	3	-	-
800001029	50	27	800	4	4	4	3	4	3	4	4	3	-	-
800001030	50	32	315	1	4	2	2	2	3	3	2	1	-	-
800001031	50	32	400	1	3	1	2	1	3	3	2	1	-	-
800001032	50	32	500	2	3	2	3	2	2	3	2	2	-	-
800001033	50	32	630	2	3	2	3	2	2	2	3	3	-	-
800001034	50	32	800	4	4	4	3	4	3	4	4	3	-	-
800001035	50	32	900	4	4	4	3	4	3	4	4	4	-	-
800001036	50	32	1000	4	4	4	3	4	3	4	4	5	-	-
800001037	50	40	400	1	3	1	2	1	3	3	2	1	-	-
800001038	50	40	500	2	3	2	3	2	2	3	2	2	-	-
800001039	50	40	630	2	3	2	3	2	2	2	3	3	-	-
800001040	50	40	800	4	4	4	3	4	3	4	4	3	-	-
800001041	50	40	900	4	4	4	3	4	3	4	4	4	-	-
800001042	50	40	1000	4	4	4	3	4	3	4	4	5	-	-
800001043	50	50	400	1	3	1	2	1	3	3	2	1	-	-
800001044	50	50	500	2	3	2	3	2	2	3	2	2	-	-
800001045	50	50	630	2	3	2	3	2	2	2	3	3	-	-
800001046	50	50												



Kód výrobku	K 7:24	d	A	Kroužky - šířka kroužku/ počet na jeden trn										dxD1xa*
				1	2	3	6	10	20	30	60	100		
800001053	30	16	200	1	3	3	1	2	2	2	-	-	-	16x42x60
800001054	30	16	250	1	3	3	1	4	2	3	-	-	-	16x42x60
800001055	30	16	315	3	3	4	1	5	3	4	-	-	-	16x42x60
800001056	30	22	200	1	3	3	1	2	2	2	-	-	-	22x42x60
800001057	30	22	250	1	3	3	1	1	2	2	1	-	-	22x42x60
800001058	30	22	315	1	4	2	2	2	3	3	1	-	-	22x42x60
800001059	30	22	400	1	3	3	1	2	3	2	3	-	-	22x42x60
800001060	30	27	200	1	1	1	1	2	2	2	-	-	-	27x48x70
800001061	30	27	250	1	1	1	1	1	2	2	1	-	-	27x48x70
800001062	30	27	315	1	2	2	1	2	3	3	1	-	-	27x48x70
800001063	30	27	400	1	1	1	1	2	1	2	2	1	-	27x48x70
800001064	40	16	200	2	1	2	2	2	1	2	-	-	-	16x56x80
800001065	40	16	250	1	3	3	1	4	1	3	-	-	-	16x56x80
800001066	40	16	315	3	3	4	1	5	2	4	-	-	-	16x56x80
800001067	40	16	400	2	3	4	2	5	3	6	-	-	-	16x56x80
800001068	40	22	200	1	3	3	1	2	1	2	-	-	-	22x56x80
800001069	40	22	250	1	3	3	1	1	1	2	1	-	-	22x56x80
800001070	40	22	315	1	4	2	2	2	2	3	1	-	-	22x56x80
800001071	40	22	400	1	3	3	1	2	2	2	3	-	-	22x56x80
800001072	40	22	500	1	3	3	1	3	2	3	4	-	-	22x56x80
800001073	40	27	250	1	3	3	1	2	2	1	1	-	-	27x56x80
800001074	40	27	315	2	2	3	2	1	1	2	2	-	-	27x56x80
800001075	40	27	400	2	1	2	2	2	3	2	1	1	-	27x56x80
800001076	40	27	500	2	1	2	2	2	3	2	1	2	-	27x56x80
800001077	40	27	630	2	3	4	2	2	3	2	3	2	-	27x56x80
800001078	40	32	250	1	3	3	1	2	2	1	1	-	-	32x56x80
800001079	40	32	315	2	2	3	2	1	1	2	2	-	-	32x56x80
800001080	40	32	400	2	1	2	2	2	3	2	1	1	-	32x56x80

Kód výrobku	K 7:24	d	A	Kroužky - šířka kroužku/ počet na jeden trn										dxD1xa*
				1	2	3	6	10	20	30	60	100		
800001081	40	32	500	2	1	2	2	2	2	3	2	1	2	32x56x80
800001082	40	32	630	2	3	4	2	2	3	2	3	2	2	32x56x80
800001083	40	40	315	2	2	3	2	1	1	2	2	-	-	40x56x80
800001084	40	40	400	2	1	2	2	2	2	3	2	1	1	40x56x80
800001085	40	40	500	2	1	2	2	2	3	2	1	2	-	40x56x80
800001086	40	40	630	2	3	4	2	2	3	2	3	2	-	40x56x80
800001087	50	22	200	1	3	1	2	1	2	1	-	-	-	22x70x100
800001088	50	22	250	1	3	1	2	1	3	2	-	-	-	22x70x100
800001089	50	22	315	1	4	2	2	1	3	2	1	-	-	22x70x100
800001090	50	22	400	1	3	1	2	1	3	1	3	-	-	22x70x100
800001091	50	22	500	2	3	4	2	4	3	3	3	-	-	22x70x100
800001092	50	22	630	2	3	4	2	4	2	4	5	-	-	22x70x100
800001093	50	27	315	2	2	3	2	2	1	2	-	-	-	27x70x100
800001094	50	27	400	2	1	2	2	4	3	2	2	-	-	27x70x100
800001095	50	27	500	2	1	2	2	3	4	3	3	-	-	27x70x100
800001096	50	27	630	2	3	4	2	2	2	3	2	-	-	27x70x100
800001097	50	27	800	2	1	2	2	3	3	3	5	2	-	27x70x100
800001098	50	32	315	2	2	3	2	2	1	1	2	-	-	32x70x100
800001099	50	32	400	2	1	2	2	4	3	2	2	-	-	32x70x100
800001100	50	32	500	2	1	2	2	3	4	3	3	-	-	32x70x100
800001101	50	32	630	2	3	4	2	2	2	2	3	2	-	32x70x100
800001102	50	32	800	2	1	2	2	3	3	3	5	2	-	32x70x100
800001103	50	32	900	2	1	2	2	3	3	3	5	3	-	32x70x100
800001104	50	32	1000	2	1	2	2	3	3	3	5	4	-	32x70x100
800001105	50	40	400	2	1	2	2	4	2	2	2	-	-	40x85x120
800001106	50	40	500	2	1	2	2	3	3	3	3	-	-	40x85x120
800001107	50	40	630	2	3	4	2	-	2	2	3	2	-	40x85x120
800001108	50	40	800	2	1	2	2	3	2	3	5	2	-	40x85x120

**7181**

■ Dlouhé frézařské trny

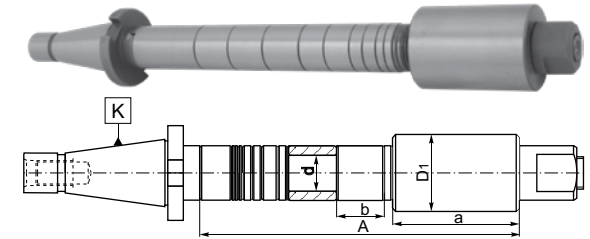

Kód výrobku	K 7:24	d	A	Kroužky - šířka kroužku/ počet na jeden trn										dxD1xa*
				1	2	3	6	10	20	30	60	100		
800001109	50	40	900	2	1	2	2	3	2	3	5	3	-	40x85x120
800001110	50	40	1000	2	1	2	2	3	2	3	5	4	-	40x85x120
800001111	50	50	400	2	1	2	2	4	2	2	2	-	-	50x85x120
800001112	50	50	500	2	1	2	2	3	3	3	3	-	-	50x85x120
800001113	50	50	630	2	3	4	2	2	1	2	3	2	-	50x85x120
800001114	50	50	800	2	1	2	2	3	2	3	5	2	-	50x85x120
800001115	50	50	900	2	1	2	2	3	2	3	5	3	-	50x85x120
800001116	50	50	1000	2	1	2	2	3	2	3	5	4	-	50x85x120
800001117	50	60	630	2	3	2	3	2	3	2	2	2	-	60x110x120
800001118	50	60	800	4	4	4	3	3	3	3	4	2	-	60x110x120
800001119	50	60	900	4	4	4	3	3	3	3	4	3	-	60x110x120
800001120	50	60	1000	4	4	4	3	3	3	3	4	4	-	60x110x120

\*Válcové pouzdro

Kód výrobku	K 7:24	d	A	Kroužky - šířka kroužku/ počet na jeden trn										dxD1xa*
				1	2	3	6	10	20	30	60	100		
800001121	30	16	315	2	2	2	2	2	3	3	-	-	-	16x42x60
800001122	30	22	315	2	2	2	2	2	3	3	-	-	-	22x42x60
800001123	30	22	400	2	1	3	1	3	4	3	1	-	-	22x42x60
800001124	30	27	315	2	2	1	3	2	2	3	-	-	-	27x48x70
800001125	30	27	400	2	1	2	2	3	3	3	1	-	-	27x48x70
800001126	40	16	315	2	2	1	3	3	2	-	-	-	-	16x48x70
800001127	40	16	400	2	3	2	3	3	4	4	-	-	-	16x48x70
800001128	40	22	315	2	2	1	3	1	3	2	-	-	-	22x56x80
800001129	40	22	400	2	1	2	2	2	4	2	1	-	-	22x56x80
800001130	40	22	500	2	1	2	2	2	3	2	3	-	-	22x56x80
800003426	40	27	315	2	2	1	3	3	2	2	-	-	-	27x56x80
800001131	40	27	400	2	1	2	2	4	3	2	1	-	-	27x56x80
800001132	40	27	500	2	3	2	3	4	3	3	2	-	-	27x56x80
800001133	40	27	630	4	4	4	3	2	2	3	3	1	-	27x56x80
800001134	40	32	315	2	2	1	3	3	2	2	-	-	-	32x56x80
800001135	40	32	400	2	1	2	2	4	3	2	1	-	-	32x56x80
800001136	40	32	500	2	3	2	3	4	3	2	-	-	-	32x56x80
800001137	40	32	630	4	4	4	3	2	2	3	3	1	-	32x56x80
800001138	40	40	315	2	2	1	3	2	2	1	-	-	-	40x70x100
800001139	40	40	400	2	1	2	2	2	2	1	-	-	-	40x70x100
800001140	40	40	500	2	3	2	3	2	2	3	2	-	-	40x70x100
800001141	40	40	630	4	4	4	3	2	3	3	2	1	-	40x70x100
800001142	50	22	315	2	2	3	2	2	2	1	-	-	-	22x70x100
800001143	50	22	400	2	1	2	2	2	3	1	-	-	-	22x70x100
800001144	50	22	500	2	1	2	2	4	3	2	2	-	-	22x70x100
800001145	50	22	630	2	1	2	2	4	2	3	4	-	-	22x70x100
800001146	50	27	315	2	2	3	2	2	2	1	-	-	-	27x70x100

\*Válcové pouzdro

Kód výrobku	K 7:24	d	A	Kroužky - šířka kroužku/ počet na jeden trn										dxD1xa*
				1	2	3	6	10	20	30	60	100		
800001147	50	27	400	2	1	2	2	3	3	3	-	-	-	27x70x100
800001148	50	27	500	2	1	2	2	4	3	2	2	-	-	27x70x100
800001149														

## 7186

■ Dlouhé frézařské trny

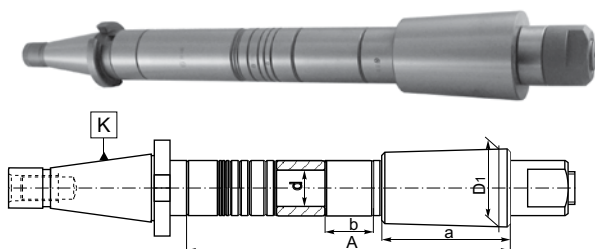

Kód výrobku	K 7:24	d	A	Kroužky - šířka kroužku/ počet na jeden trn										dxD1xa*
				1	2	3	6	10	20	30	60	100		
800001174	40	22	200	1	3	3	1	2	1	2	-	-	22x47x80	
800001175	40	22	250	1	3	3	1	1	1	2	1	-	22x47x80	
800001176	40	22	315	1	4	2	2	2	2	3	1	-	22x47x80	
800001177	40	22	400	1	3	3	1	2	2	2	3	-	22x47x80	
800001178	40	22	500	1	3	3	1	3	2	3	4	-	22x47x80	
800001179	40	27	250	1	3	3	1	2	2	1	1	-	27x47x80	
800001180	40	27	315	2	2	3	2	1	1	2	2	-	27x47x80	
800001181	40	27	400	2	1	2	2	2	3	2	1	1	27x47x80	
800001182	40	27	500	2	1	2	2	2	3	2	1	2	27x47x80	
800001183	40	27	630	2	3	4	2	2	3	2	3	2	27x47x80	
800001184	40	32	250	1	3	3	1	2	2	1	1	-	32x47x80	
800001185	40	32	315	2	2	3	2	1	1	2	2	-	32x47x80	
800001186	40	32	400	2	1	2	2	2	3	2	1	1	32x47x80	
800001187	40	32	500	2	1	2	2	2	3	2	1	2	32x47x80	
800001188	40	32	630	2	3	4	2	2	3	2	3	2	32x47x80	
800001189	50	22	200	1	3	1	2	1	2	1	-	-	22x70x100	
800001190	50	22	250	1	3	1	2	1	3	2	-	-	22x70x100	
800001191	50	22	315	1	4	2	2	1	3	2	1	-	22x70x100	
800001192	50	22	400	1	3	1	2	1	3	1	3	-	22x70x100	
800001193	50	22	500	2	3	4	2	4	3	3	3	-	22x70x100	
800001194	50	22	630	2	3	4	2	4	2	4	5	-	22x70x100	
800001195	50	27	315	2	2	3	2	2	1	1	2	-	27x70x100	
800001196	50	27	400	2	1	2	2	4	3	2	2	-	27x70x100	
800001197	50	27	500	2	1	2	2	3	4	3	3	-	27x70x100	

\*Válcové pouzdro

Kód výrobku	K 7:24	d	A	Kroužky - šířka kroužku/ počet na jeden trn										dxD1xa*
				1	2	3	6	10	20	30	60	100		
800001198	50	27	630	2	3	4	2	2	2	2	3	2	27x70x100	
800001199	50	27	800	2	1	2	2	3	3	3	5	2	27x70x100	
800001200	50	32	315	2	2	3	2	2	1	1	2	-	32x70x100	
800001201	50	32	400	2	1	2	2	4	3	2	2	-	32x70x100	
800001202	50	32	500	2	1	2	2	3	4	3	3	-	32x70x100	
800001203	50	32	630	2	3	4	2	2	2	2	3	2	32x70x100	
800001204	50	32	800	2	1	2	2	2	3	3	5	2	32x70x100	
800001205	50	32	900	2	1	2	2	3	3	3	5	3	32x70x100	
800001206	50	32	1000	2	1	2	2	3	3	3	5	4	32x70x100	
800001207	50	40	400	2	1	2	2	4	3	2	2	-	40x70x100	
800001208	50	40	500	2	1	2	2	3	4	3	3	-	40x70x100	
800001209	50	40	630	2	3	4	2	2	2	2	3	2	40x70x100	
800001210	50	40	800	2	1	2	2	3	3	3	5	2	40x70x100	
800001211	50	40	900	2	1	2	2	3	3	3	5	3	40x70x100	
800001212	50	40	1000	2	1	2	2	3	3	3	5	4	40x70x100	
800001213	50	50	400	2	1	2	2	4	3	2	2	-	50x86x100	
800001214	50	50	500	2	1	2	2	3	4	3	3	-	50x86x100	
800003427	50	50	630	2	3	4	2	2	2	2	3	2	50x86x100	
800003428	50	50	800	2	1	2	2	3	3	3	5	2	50x86x100	
800003429	50	50	900	2	1	2	2	2	3	3	5	3	50x86x100	
800003430	50	50	1000	2	1	2	2	2	3	3	5	4	50x86x100	
800003431	50	60	630	2	3	4	2	2	2	2	3	2	63x86x100	
800003432	50	60	800	2	1	2	2	3	3	3	5	2	63x86x100	
800003433	50	60	900	2	1	2	2	3	3	3	5	3	63x86x100	
800003434	50	60	1000	2	1	2	2	3	3	3	5	4	63x86x100	

## 7188

■ Dlouhé frézařské trny

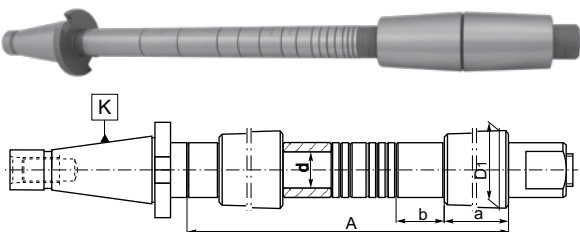

Kód výrobku	K 7:24	d	A	Kroužky - šířka kroužku/ počet na jeden trn										dxD1xa*
				1	2	3	6	10	20	30	60	100		
800001215	40	22	315	2	2	1	3	1	3	2	-	-	22x47x80	
800001216	40	22	400	2	1	2	2	2	4	2	1	-	22x47x80	
800001217	40	22	500	2	1	2	2	2	3	2	3	-	22x47x80	
800001218	40	27	315	2	2	1	3	3	2	2	-	-	22x47x80	
800001219	40	27	400	2	1	2	2	4	3	2	1	-	22x47x80	
800001220	40	27	500	2	3	2	3	4	3	3	2	-	22x47x80	
800001221	40	27	630	4	4	4	3	2	2	3	3	1	22x47x80	
800001222	40	32	315	2	2	1	3	3	2	2	-	-	32x47x80	
800001223	40	32	400	2	1	2	2	4	3	3	2	-	32x47x80	
800001224	40	32	500	2	3	2	3	4	3	3	2	-	32x47x80	
800001225	40	32	630	4	4	4	3	2	2	3	3	1	32x47x80	
800001226	50	22	315	2	2	3	2	2	2	1	-	-	22x70x100	
800001227	50	22	400	2	1	2	2	3	3	3	-	-	22x70x100	
800001228	50	22	500	2	1	2	2	4	3	2	2	-	22x70x100	
800001229	50	22	630	2	1	2	2	4	2	3	4	-	22x70x100	
800001230	50	27	315	2	2	3	2	2	2	1	-	-	22x70x100	
800001231	50	27	400	2	1	2	2	3	3	3	-	-	22x70x100	
800001232	50	27	500	2	1	2	2	4	3	2	2	-	22x70x100	
800001233	50	27	630	4	4	4	3	4	2	3	2	1	22x70x100	
800001234	50	27	800	4	4	4	3	2	2	4	3	2	22x70x100	
800001235	50	32	315	2	2	3	2	2	2	1	-	-	32x70x100	
800001236	50	32	400	2	1	2	2	3	3	3	-	-	32x70x100	

\*Pouzdro

Kód výrobku	K 7:24	d	A	Kroužky - šířka kroužku/ počet na jeden trn										dxD1xa*
				1	2	3	6	10	20	30	60	100		
800001237	50	32	500	2	1	2	2	4	3	2	2	-	32x70x100	
800001238	50	32	630	4	4	4	3	4	2	3	2	1	32x70x100	
800001239	50	32	800	4	4	4	3	2	2	4	3	2	32x70x100	
800001240	50	32	900	4	4	4	3	2	2	4	3	3	32x70x100	
800001241	50	32	1000	4	4	4	3	2	2	4	3	4	32x70x100	
800001242	50	40	400	2	1	2	2	3	3	3	-	-	40x70x100	
800001243	50	40	500	2	1	2	2	4	3	2	2	-	40x70x100	
800001244	50	40	630	4	4	4	3	4	2	3	2	1	40x70x100	
800001245	50	40	800	4	4	4	3	2	2	4	3	2	40x70x100	
800001246	50	40	900	4	4	4	3	2	2	4	3	3	40x70x100	
800001247	50	40	1000	4	4	4	3	2	2	4	3	4	40x70x100	
800001248	50	50	400	2	1	2	2	3	3	3	-	-	50x86x100	
800001249	50	50	500	2	1	2	2	4	3	2	2	-	50x86x100	
800001250	50	50	630	4	4	4	3	4	2	3	2	1	50x86x100	
800001251	50	50	800	4	4	4	3	2	2	4	3	2	50x86x100	
800001252	50	50	900	4	4	4	3	2	2	4	3	3	50x86x100	
800001253	50	50	1000	4	4	4	3	2	2	4	3	4	50x86x100	
800001254	50	60	630	4	4	4	3	4	2	3	2	1	60x86x100	
800001255	50	60	800	4	4	4	3	2	2	4	3	2	60x86x100	
800001256	50	60	900	4	4	4	3	2	2	4	3	3	60x86x100	
800001257	50	60	1000	4	4	4	3	2	2	4	3	4	60x86x100	

## 1679

- Univerzální redukční pouzdra pro nástroje se stopkou Morse se závitem nebo unáščem

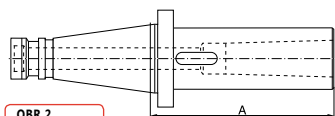
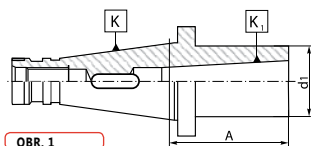

\* pouze pro nástroje s kuzelem Morse dle DIN 228-B

Kód výrobku	K 7:24	K, MK	A	d <sub>1</sub>	Obr.
800000177	30	1	50	25	1
800000178	30	2*	50	32	1
800000179	30	3*	72	40	1
800000180	40	1	50	25	1
800000181	40	1	92	25	2
800000182	40	2	50	32	1
800000183	40	2	109	32	2
800000184	40	3*	65	40	1
800000185	40	3*	129	40	2
800000186	40	4*	95	48	1
800000187	40	4*	152	48	2
800000188	50	1	45	25	1
800000189	50	1	96	25	2
800000190	50	2	60	32	1
800000191	50	2	113	32	2
800000192	50	3	65	40	1
800000193	50	3	133	40	2
800000194	50	4	70	48	1
800000195	50	4	163	48	2
800000196	50	5*	105	63	1
800000197	50	5*	193	63	2

## 1657

- Redukční pouzdra pro nástroje s kuzelem Morse s unáščem

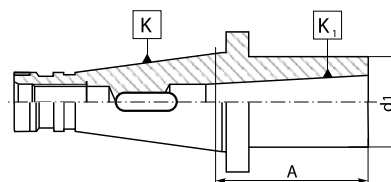

Kód výrobku	K 7:24	K, MK	A	d <sub>1</sub>
800000113	30	1	50	25
800000114	30	2	57	32
800000115	30	3	72	40
800000116	40	1	50	25
800000117	40	2	50	32
800000118	40	3	65	40
800000119	40	4	95	48
800000120	40	5	170	63
800000121	50	2	23	32
800000122	50	3	33	40
800000123	50	4	53	48
800000124	50	5	86	63

## 1676

- Redukční pouzdra pro nástroje s kuzelem Morse se závitem

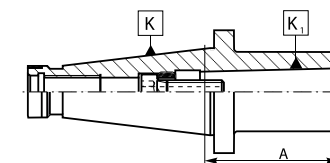
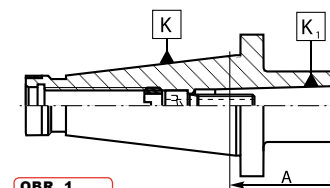

Kód výrobku	K 7:24	K, MK	A	d <sub>1</sub>	Obr.	
800000165	30	1	50	25	1	U-2369/0
800000166	30	2	50	32	2	W-1092/0
800000167	30	3	78	40	2	U-7790/0
800000168	40	1	50	25	1	W-1091/0
800000169	40	2	50	32	1	W-1092/0
800000170	40	3	65	40	2	W-1093/0
800000171	40	4	95	48	2	W-1094/0
800000172	50	1	45	25	1	W-1091/0
800000173	50	2	60	32	1	W-1095/0
800000174	50	3	65	40	1	W-1096/0
800000175	50	4	65	48	1	W-1097/0
800000176	50	5	120	63	2	W-1098/0

## 1655

- Redukční pouzdra (vločky) pro nástroje s kuzelem Morse se závitem
- Pro přímé upnutí nástroje pomocí šroubu v ose vřetene

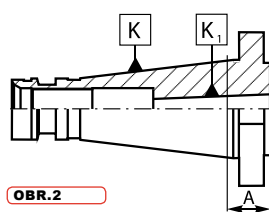
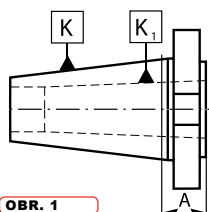

OBR. 1

OBR. 2

Kód výrobku	K 7:24	K <sub>1</sub> MK	A	Obr.
800000101	30	2	18	1
800000102	30	3	72	1
800000103	40	1	14	2
800000104	40	2	14	1
800000105	40	3	14	1
800000106	40	4	43	1
800000107	40	4	67	1
800000108	50	1	17	2
800000109	50	2	21	1
800000110	50	3	21	1
800000111	50	4	21	1
800000112	50	5	65	1

## 1653

- Redukční pouzdra pro nástroje s kuzelem Morse se závitem

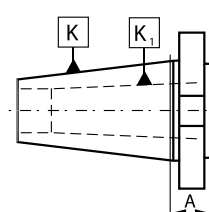
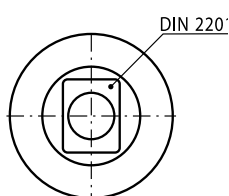

Kód výrobku	K 7:24	K <sub>1</sub> MK	A
800000096	40	3	38
800000097	40	4	61
800000098	50	3	16
800000099	50	4	22
800000100	50	5	51

## 1650

- Redukční pouzdra pro nástroje s kuzelem dle DIN 2080

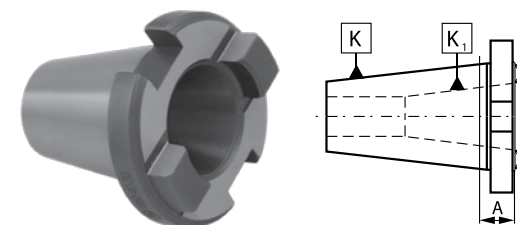

Kód výrobku	K 7:24	K <sub>1</sub> 7:24	A
800000093	40	30	13,0
800000094	50	30	15,9
800000095	50	40	15,9

## 1699

- Redukční pouzdra pro nástroje s kuzelem 7:24

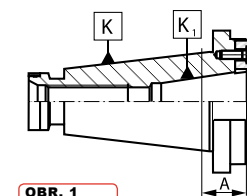

OBR. 1

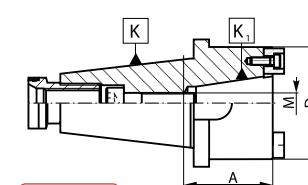

OBR. 2

Kód výrobku	K 7:24	K <sub>1</sub> 7:24	A	Obr.	D	M	
800000285	50	40	27	1	88	M16	U-6227/0
800000286	50	40	65	2	88	M16	U-6227/0

## 7657

- Vrtací sklíčidlo samosvorné
- Klíč je součástí dodávky

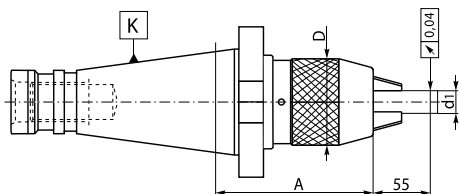

Kód výrobku	K 7:24	d <sub>1</sub>	A	D
800002398	40	1-13	88	50
800002399	40	1-13	99	57
800002400	50	3-16	85	50
800002401	50	3-16	89	57

## 7662

- Vrtací sklíčidlo pro pravé i levé otáčky upínané "inbus" klíčem
- Klíč je součástí dodávky

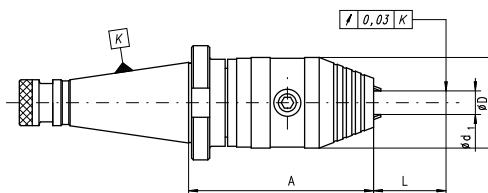

Kód výrobku	K 7:24	d <sub>1</sub>	Upínací moment	A	D
800006593	40	1-13	40Nm	102	50
800006594	40	3-16	45Nm	102	50
800006595	50	1-13	40Nm	99	50
800006596	50	3-16	45Nm	99	50

## 2190

- Polotovary

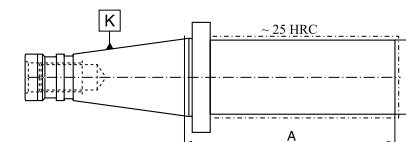

Kód výrobku	K 7:24	D	A
800000551	40	40	280
800000554	40	63	280
800000556	50	50	330
800000558	50	80	330

## 2850

- Kontrolní trny



Kód výrobku	K 7:24	D	L
800006690	40	40	300
800006691	50	50	300

## HSK-A (DIN 69893-A)

- Materiál: legovaná ocel chrom-manganová
- Cementováno do hloubky 0,7mm
- Kaleno a přesně broušeno
- Tvrdost povrchů 58±2 HRC
- Tolerance úhlu kuželu AT3
- Standardně vyváženo ve třídě G 6,3/20000 ot./min  
(Jiné parametry vyvážení na objednávku)

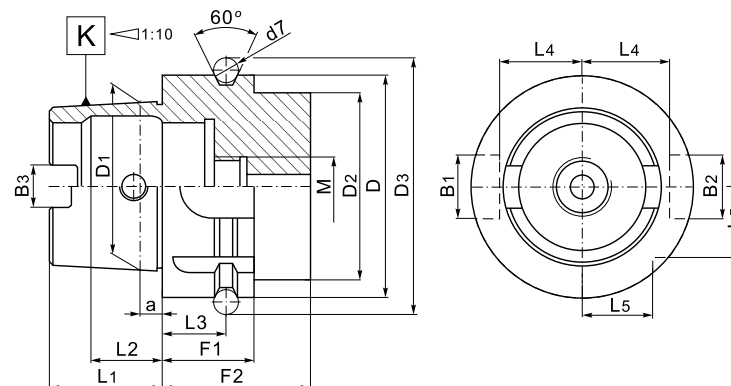

Upínače HSK-A BISON je možné použít ve strojích se zakončením dle HSK-C !

Upínače v jiných normách HSK jsou na poptávku!



K HSK-A	D	D <sub>1</sub>	D <sub>2,max</sub>	D <sub>3</sub>	B <sub>1</sub>	B <sub>2</sub>	B <sub>3</sub>	a	d <sub>7</sub>	L <sub>1</sub>	L <sub>2</sub>	L <sub>3</sub>	L <sub>4</sub>	L <sub>5</sub>	F <sub>1</sub>	F <sub>2</sub>	M
63	63	48	53	72,3	18	16	12,54	6,3	7	32	18,13	18	26,5	20	26	42	M18x1
100	100	75	85	109,75	22	20	20,2	10	7	50	28,56	20	44	31,5	29	45	M24x1,5

## 7887

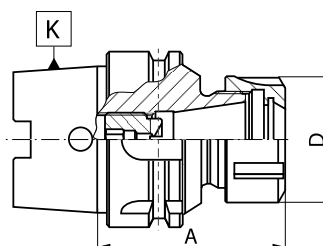
- Kleštinové upínače pro kleštiny ER (DIN 6499)



6,3/20000

Kód výrobku	K HSK-A	Kleština	A	Rozsah upínání	D		
800003467	63	ER11	63	2-7	19	9833-11D	M8x1x8LH
800003468	63	ER11	100	2-7	19	9833-11D	M8x1x8LH
800003469	63	ER16	90	2-10	32	9833-16ES	M10x11LH
800003470	63	ER16	100	2-10	32	9833-16ES	M10x11LH
800003471	63	ER16	120	2-10	32	9833-16ES	M10x11LH
800003472	63	ER16	160	2-10	32	9833-16ES	M10x11LH
800002727	63	ER25	80	2-16	42	9833-25ES	M8x16
800003473	63	ER25	160	2-16	42	9833-25ES	M8x16
800002728	63	ER32	100	2-20	50	9833-32ES	M10x20
800003474	63	ER32	160	2-20	50	9833-32ES	M10x20
800002729	63	ER40	120	2-26	63	9833-40ES	M12x30
800006285	100	ER25	100	2-16	42	9833-25ES	M8x16
800006286	100	ER32	100	2-20	50	9833-32ES	M10x20
800006287	100	ER40	100	2-26	63	9833-40ES	M12x30

6,3/20000

**7885**

■ Frézařské trny pro nástroje s válcovou stopkou dle DIN 1835-B (WELDON)

Kód výrobku	K HSK-A	d	A	D		Obr.
800002719	63	6	65	25	U-4131/0	1
800003456	63	6	120	25	U-4131/0	1
800003457	63	6	160	25	U-4131/0	1
800002720	63	8	65	28	U-4132/0	1
800003458	63	8	120	28	U-4132/0	1
800003459	63	8	160	28	U-4132/0	1
800002721	63	10	65	35	U-4133/0	1
800003460	63	10	120	35	U-4133/0	1
800003461	63	10	160	35	U-4133/0	1
800002722	63	12	80	42	U-4134/0	1
800003462	63	12	120	42	U-4134/0	1
800003463	63	14	80	44	U-4134/0	1
800003464	63	14	120	44	U-4134/0	1
800002723	63	16	80	48	U-4135/0	1
800003465	63	16	120	48	U-4135/0	1
800003466	63	18	80	50	U-4135/0	1
800002724	63	20	80	52	U-4136/0	1
800002725	63	25	110	63	2xU-4137/0	2
800002726	63	32	110	72	2xU-4138/0	2
800006288	100	6	80	25	U-4131/0	1
800006289	100	8	80	28	U-4132/0	1
800006290	100	10	80	35	U-4133/0	1
800006291	100	12	80	42	U-4134/0	1
800006292	100	14	80	44	U-4134/0	1
800006293	100	16	100	48	U-4135/0	1
800006294	100	18	100	50	U-4135/0	1
800006295	100	20	100	52	U-4136/0	1
800006296	100	25	100	63	2xU-4137/0	2
800006297	100	32	100	72	2xU-4138/0	2
800006298	100	40	100	80	2xU-4138/0	2

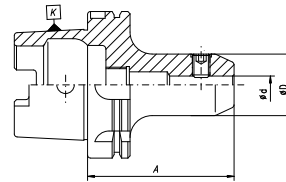

OBR. 1

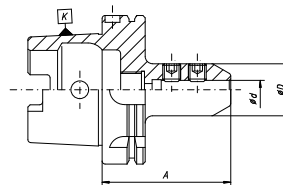

OBR. 2

6,3/20000

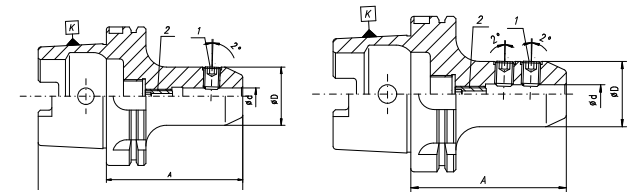

**7886**

■ Frézařské trny pro nástroje s válcovou stopkou dle DIN 1835-E (Whistle-Notch)



OBR. 1

OBR. 2

Kód výrobku	K HSK-A	d	A	D			Obr.
					Poz.1	Poz.2	
800006299	100	6	90	25	U-4131/0	U-1599/0	1
800006300	100	8	90	28	U-4132/0	U-6317/0	1
800006301	100	10	90	35	U-4133/0	U-0293/0	1
800006302	100	12	100	42	U-4134/0	U-0757/0	1
800006303	100	14	100	44	U-4135/0	U-6318/0	1
800006304	100	16	100	48	U-4135/0	U-6318/0	1
800006305	100	18	100	50	U-4136/0	U-6318/0	1
800006306	100	20	110	52	U-4136/0	U-6318/0	1
800006307	100	25	120	65	2xU-4137/0	2xU-6318/0	2
800006308	100	32	120	72	2xU-4138/0	2xU-6318/0	2
800006309	100	40	120	80	2xU-4138/0	2xU-6318/0	2

## 7888

6,3/20000

- Frézařské trny pro frézy s příčnou unášecí drážkou

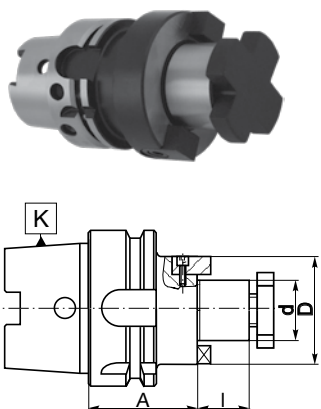

Kód výrobku	K HSK-A	d	A	L	D		
800002730	63	16	45	17	32	U-0620/0	S-2117/0
800003400	63	16	80	17	32	U-0620/0	S-2117/0
800003401	63	16	145	17	32	U-0620/0	S-2117/0
800002731	63	22	50	19	40	U-0621/0	S-2121/0
800003402	63	22	80	19	40	U-0621/0	S-2121/0
800003403	63	22	150	19	40	U-0621/0	S-2121/0
800002732	63	27	60	21	48	U-0622/0	S-2111/0
800003404	63	27	155	21	48	U-0622/0	S-2111/0
800002733	63	32	60	24	58	U-0623/0	W-3649/0
800002734	63	40	60	27	70	U-0623/0	S-2114/0
800006325	100	22	50	19	40	U-0621/0	S-2121/0
800006326	100	27	50	21	48	U-0622/0	S-2111/0
800006327	100	32	50	24	58	U-0623/0	W-3649/0
800006328	100	40	60	27	70	U-0624/0	S-2124/0
800006329	100	50	70	30	90	U-0625/0	U-5974/0

## 7889

6,3/20000

- Frézařské trny univerzální

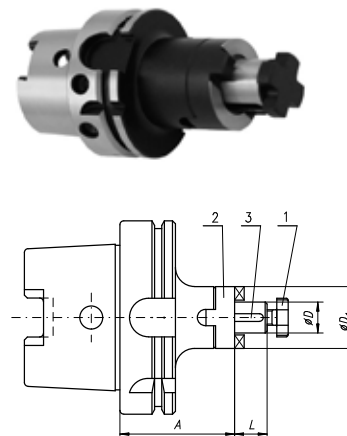

Kód výrobku	K HSK-A	D	A	D1	L	Pero		
						Poz.1	Poz.2	Poz.3
800006320	100	16	60	32	17	U-0620/0	U-1364/0	U-1355/0
800006321	100	22	60	40	19	U-0621/0	U-1365/0	U-1356/0
800006322	100	27	60	48	21	U-0622/0	U-1366/0	U-1357/0
800006323	100	32	60	58	24	U-0623/0	U-1367/0	U-6355/0
800006324	100	40	70	70	27	U-0624/0	U-1368/0	U-1359/0

## 7895

6,3/20000

- Frézařské trny pro frézy se závitem
- S kuželem HSK-100A na poptávku

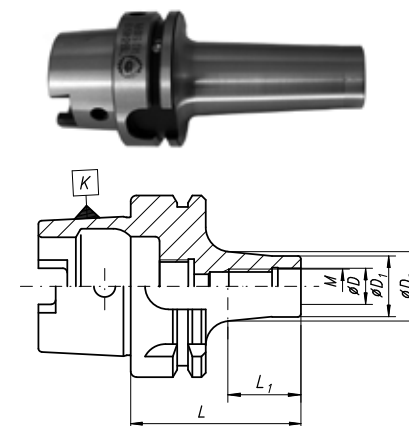

Kód výrobku	K HSK-A	M	L	L1	D	D1	D2
800006920	63	M8	59	25	8,5	13	15
800006921	63	M8	84	50	8,5	13	23
800006922	63	M8	109	75	8,5	13	23
800006923	63	M8	134	100	8,5	13	25
800006924	63	M10	59	25	10,5	18	20
800006925	63	M10	84	50	10,5	18	25
800006926	63	M10	109	75	10,5	18	28
800006927	63	M10	134	100	10,5	18	30
800006928	63	M10	159	125	10,5	18	34
800006929	63	M12	59	25	12,5	21	24
800006930	63	M12	84	50	12,5	21	24
800006931	63	M12	109	75	12,5	21	31
800006932	63	M12	134	100	12,5	21	30
800006933	63	M12	159	125	12,7	21	34
800006934	63	M16	59	25	17	29	34
800006935	63	M16	84	50	17	29	34
800006936	63	M16	109	75	17	29	34
800006937	63	M16	134	100	17	29	39
800006938	63	M16	159	125	17	29	39

1  
2  
3  
4  
5  
6  
7



6,3/20000

**7872**

■ Frézařské trny pro kotoučové frézy

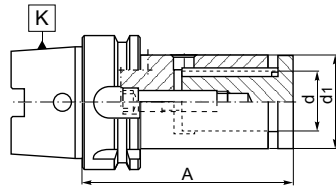

Kód výrobku	K HSK-A	d	d1	A	Rozsah upínání			
800003396	63	16	29	125	0-16	W-4988/0	U-6511/0	U-6527/0
800003397	63	22	36	125	0-20	W-4989/0	U-6513/0	U-6529/0
800003398	63	27	42	125	0-20	W-4989/0	U-6515/0	U-6531/0
800003399	63	32	50	125	0-20	W-4989/0	U-6517/0	U-6533/0

6,3/20000

**7890**

■ Redukční pouzdra pro nástroje s kuželem Morse s unašečem

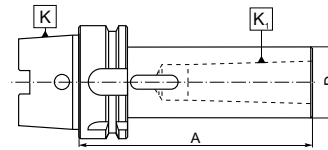
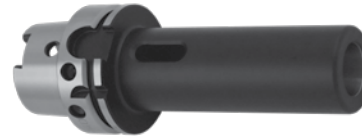

Kód výrobku	K HSK-A	K <sub>1</sub> MK	A	D
800002735	63	1	100	25
800002736	63	2	120	32
800002737	63	3	140	40
800002738	63	4	160	48
800006310	100	1	110	25
800006311	100	2	120	32
800006312	100	3	150	40
800006313	100	4	170	48
800006314	100	5	200	63

6,3/20000

**7892**

■ Redukční pouzdra pro nástroje s kuželem Morse se závitem

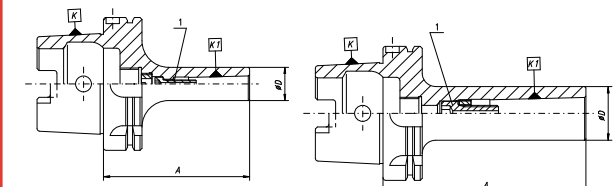

OBR. 1

OBR. 2

Kód výrobku	K HSK-A	K <sub>1</sub> MK	A	D		Obr.
800006315	100	1	110	25	W-1091/0	1
800006316	100	2	120	32	W-1092/0	1
800006317	100	3	150	40	W-1093/0	2
800006318	100	4	170	48	W-1094/0	2
800006319	100	5	200	63	C-0220/0	2

## 5391

6,3/20000

- Vrtací sklíčidlo samosvorné
- Klíč je součástí dodávky

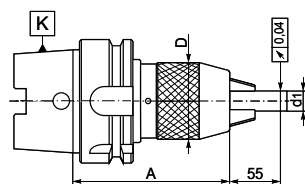
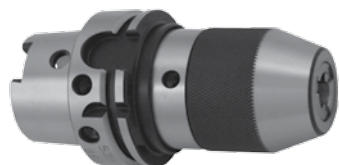

Kód výrobku	K HSK-A	d <sub>i</sub>	A	D
800000902	63	1-13	150	50
800000903	63	3-16	157	57

## 5392

6,3/20000

- Vrtací sklíčidlo pro pravé i levé otáčky upínané "inbus" klíčem
- Klíč je součástí dodávky

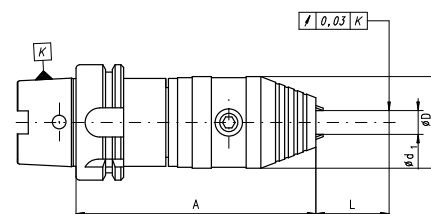

Kód výrobku	K HSK-A	d <sub>i</sub>	Upínací moment	A	D
800006581	63	1-13	40Nm	163	50
800006582	63	3-16	45Nm	163	50
800006583	100	1-13	40Nm	170	50
800006584	100	3-16	45Nm	170	50

## 7891

- Polotovary

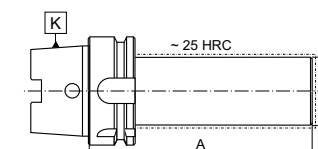

Kód výrobku	K HSK-A	D	A
800002739	63	63	150
800003405	63	80	250
800006330	100	250	97

## 2856

- Kontrolní trny

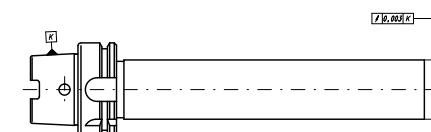

Kód výrobku	K HSK-A	D	L
800006696	63	40	300
800006697	100	50	300

## 1313

■ Trubička pro přívod chladiva

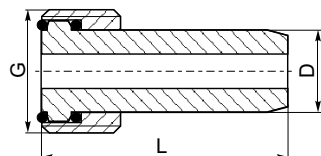

Kód výrobku	K HSK-A	G	L	D
800003721	63	M18x1	36,5	12
800006824	100	M24x1,5	44	16

## 6,3/20000

Kód výrobku	K HSK-A	d <sub>1</sub>	L	L <sub>1</sub>	D <sub>2</sub>	D <sub>3</sub>
800006449	63	3	80	36	14	22
800006450	63	3	120	36	14	22
800006451	63	3	160	36	14	22
800006452	63	4	80	36	14	22
800006453	63	4	120	36	14	22
800006454	63	4	160	36	14	22
800006455	63	5	80	36	16	22
800006456	63	5	120	36	16	22
800006457	63	5	160	36	16	22
800006458	63	6	80	36	21	27
800006459	63	6	120	36	21	27
800006460	63	6	160	36	21	27
800006461	63	8	80	36	21	27
800006462	63	8	120	36	21	27
800006463	63	8	160	36	21	27
800006464	63	10	85	42	24	32
800006465	63	10	120	42	24	32
800006466	63	10	160	42	24	32
800006467	63	12	90	47	24	32
800006468	63	12	120	47	24	32
800006469	63	12	160	47	24	32
800006470	63	14	90	47	27	34
800006471	63	14	120	47	27	34
800006472	63	14	160	47	27	34
800006473	63	16	95	50	27	34
800006474	63	16	120	50	27	34
800006475	63	16	160	50	27	34
800006476	63	18	95	50	33	42
800006477	63	18	120	50	33	42
800006478	63	18	160	50	33	42
800006479	63	20	100	52	33	42
800006480	63	20	120	52	33	42
800006481	63	20	160	52	33	42
800006482	63	25	115	58	44	53
800006483	63	25	120	58	44	53
800006484	63	25	160	58	44	53
800006485	63	32	115	58	44	53



## 7634

- Tepelné upínače
- Vhodné pro HSS a tvrdokovové nástroje s válcovou stopkou (tolerance h6)
- Max. házivost = 0,003mm
- Max. ohřívací teplota 500°C
- Provedení s úhlem 3° je na objednávku!

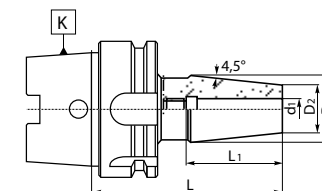

\* Provedení 3° - na objednávku!

Kód výrobku	K HSK-A	d <sub>1</sub>	L	L <sub>1</sub>	D <sub>2</sub>	D <sub>3</sub>
800006486	100	6	85	36	21	27
800006487	100	6	120	36	21	27
800006488	100	6	160	36	21	27
800006489	100	8	85	36	21	27
800006490	100	8	120	36	21	27
800006491	100	8	160	36	21	27
800006492	100	10	90	42	24	32
800006493	100	10	120	42	24	32
800006494	100	10	160	42	24	32
800006495	100	12	95	47	24	32
800006496	100	12	120	47	24	32
800006497	100	12	160	47	24	32
800006498	100	14	95	47	27	34
800006499	100	14	120	47	27	34
800006500	100	14	160	47	27	34
800006501	100	16	100	50	27	34
800006502	100	16	120	50	27	34
800006503	100	16	160	50	27	34
800006504	100	18	100	50	33	42
800006505	100	18	120	50	33	42
800006506	100	18	160	50	33	42
800006507	100	20	105	52	33	42
800006508	100	20	120	52	33	42
800006509	100	20	160	52	33	42
800006510	100	25	115	58	44	53
800006511	100	25	160	58	44	53
800006512	100	32	120	58	44	53
800006513	100	32	160	58	44	53

## DIN 228

- Materiál: legovaná ocel chrom-manganová
- Cementováno do hloubky 0,7mm
- Kaleno a přesně broušeno
- Tvrdost povrchů 58±2 HRC

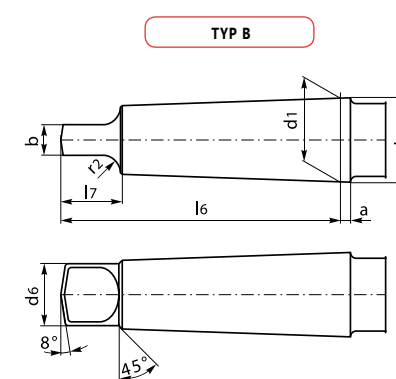
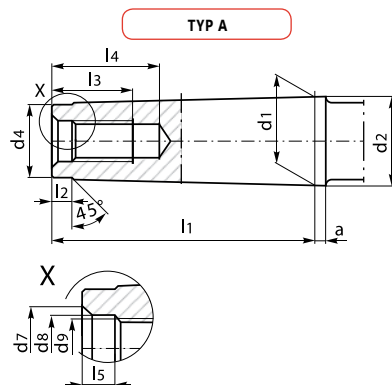

Kužel MK	a	b	d <sub>1</sub>	d <sub>2</sub>	d <sub>4</sub>	d <sub>6</sub>	d <sub>7</sub>	d <sub>8</sub>	d <sub>9</sub>
0	3	3.9	9,045	9,2	6	6	—	—	—
1	3,5	5,2	12,065	12,2	9	8,7	8,5	6,4	M6
2	5	6,3	17,780	18	14	13,5	13,2	10,5	M10
3	5	7,9	23,825	24,1	19	18,5	16	13	M12
4	6,5	11,9	31,267	31,6	25	24,5	21,5	17	M16
5	6,5	15,9	44,399	44,7	35,7	35,7	26	21	M20
6	8	19,0	63,348	63,8	51	51	32	25	M24
7	9,5	28,5	83,058	83,5	66	66,8	—	—	—

Kužel MK	l <sub>1</sub>	l <sub>2</sub>	l <sub>3</sub>	l <sub>4</sub>	l <sub>5</sub>	l <sub>6</sub>	l <sub>7</sub>	r <sub>2</sub>	a/2
0	50	4	—	—	—	56,5	10,5	4	1°29'27"
1	53,5	5	16	22	4	62	13,5	5	1°25'43"
2	64	5	24	31,5	5	75	16	6	1°25'50"
3	81	7	24	33,5	5,5	94	20	7	1°26'16"
4	102,5	9	32	42,5	8,2	117,5	24	8	1°29'15"
5	129,5	10	40	52,5	10	149,5	29	10	1°30'26"
6	182	16	47	61,5	11,5	210	40	13	1°29'36"
7	250,5	18	—	—	—	286	54	19	1°29'22"

## 7711

- Kleštinové upínače pro kleštiny ER (DIN 6499)
- Jiné rozměry na poptávku

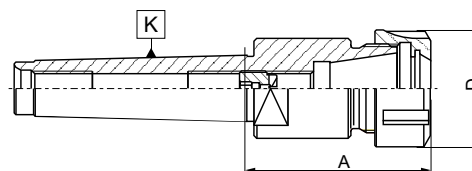

Kód výrobku	Kužel MK	Kleština	A	Rozsah upínání	D		
800002402	2	ER16	43,5	2-10	32	9833-16	M10x11LH
800002403	2	ER20	47,5	2-13	35	9833-20	M10x11LH
800005134	2	ER25	57,0	2-16	42	9833-25	M10x11LH
800002404	2	ER32	65,5	2-20	50	9833-32	M10x11LH
800002405	3	ER16	43,5	2-10	32	9833-16	M12x1,5x14LH
800002406	3	ER20	45,5	2-13	35	9833-20	M12x1,5x14LH
800002407	3	ER25	68,0	2-16	42	9833-25	M12x1,5x14LH
800002408	3	ER32	73,5	2-20	50	9833-32	M12x1,5x14LH
800005135	3	ER40	85,0	2-26	63	9833-40	M12x1,5x14LH
800002409	4	ER25	54,5	2-16	42	9833-25	M18x1,5x19LH
800002410	4	ER32	84,0	2-20	50	9833-32	M18x1,5x19LH
800003780	4	ER40	80,0	2-26	63	9833-40	M18x1,5x19LH
800002411	5	ER32	65,5	2-20	50	9833-32	M22x1,5x24LH
800002412	5	ER40	67,5	2-26	63	9833-40	M22x1,5x24LH

**7711-KPL**
**7711-PL**

- Kleštinové upínače pro kleštiny ER (DIN 6499) se sadou kleštín



Kód výrobku	Kužel MK	Kleštiny	A	Rozsah upínání	Počet kleštín v sadě
<b>7711-KPL</b>					
800002413	2	ER16	43,5	2-10	8
800002414	2	ER20	47,5	2-13	11
800002415	2	ER32	65,5	2-20	18
800002416	3	ER16	43,5	2-10	8
800002417	3	ER20	45,5	2-13	11
800002418	3	ER25	68	2-16	14
800002419	3	ER32	73,5	2-20	18
800002420	4	ER25	54,5	2-16	14
800002421	4	ER32	84	2-20	18
800002422	5	ER32	65,5	2-20	18
800002423	5	ER40	67,5	2-26	24
<b>7711-PL</b>					
800002424	3	ER32	73,5	3-20	8
Kleštiny Ø 4,5,6,8,10,12,16,20					
800002425	4	ER32	84	3-20	8
Kleštiny Ø 4,5,6,8,10,12,16,20					
800002426	5	ER32	65,5	3-20	8
Kleštiny Ø 4,5,6,8,10,12,16,20					

**7720**
**7721**

- Frézařské trny pro nástroje s válcovou stopkou dle DIN 1835-B (WELDON)/ verze s našaňcem
- Frézařské trny pro nástroje s válcovou stopkou dle DIN 1835-B (WELDON) / verze se závitem

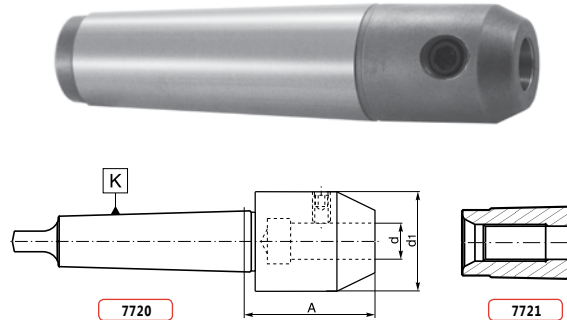

Kód výrobku		Kužel MK	d	d <sub>1</sub>	A	
7720	7721					
800002427	800002449	2	6	25	50,0	U-4131/0
800002428	800002450	2	8	28	50,0	U-4132/0
800002429	800002685	2	10	35	55,0	U-4133/0
800002430	800002686	2	12	42	68,0	U-4134/0
800002431	800002687	2	16	48	70,0	U-4135/0
800002432	800002688	3	6	25	50,0	U-4131/0
800002433	800002689	3	8	28	50,0	U-4132/0
800002434	800002690	3	10	35	55,0	U-4133/0
800003499	800002691	3	12	42	68,0	U-4134/0
800002435	800002692	3	16	48	76,0	U-4135/0
800002436	800002693	3	20	52	76,0	U-4136/0
800002437	800002694	4	6	25	51,5	U-4131/0
800002438	800002695	4	8	28	51,5	U-4132/0
800002439	800002696	4	10	35	56,5	U-4133/0
800002440	800002697	4	12	42	62,5	U-4134/0
800002441	800002698	4	16	48	62,5	U-4135/0
800002442	800002699	4	20	52	77,5	U-4136/0
800002443	800002700	5	6	25	51,5	U-4131/0
800002444	800002701	5	8	28	51,5	U-4132/0
800002445	800002702	5	10	35	62,5	U-4133/0
800002446	800002703	5	12	42	69,5	U-4134/0
800002447	800002704	5	16	48	69,5	U-4135/0
800002448	800002705	5	20	52	69,5	U-4136/0

**7430**

- Frézařské trny univerzální
- Trny s drážkou na zaklínování jsou na poptávku !

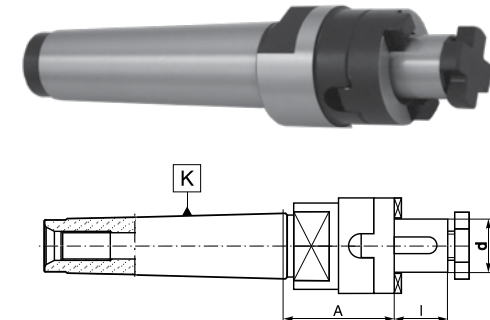

Kód výrobku	Kužel MK	d	A	l			
800001686	2	16	46	17	U-0620/0	U-1364/0	U-1355/0
800001687	2	16	61	17	U-0620/0	U-1364/0	U-1355/0
800001688	2	22	46	19	U-0621/0	U-1365/0	U-1356/0
800001689	2	22	61	19	U-0621/0	U-1365/0	U-1356/0
800001690	3	16	48	17	U-0620/0	U-1364/0	U-1355/0
800001691	3	16	63	17	U-0620/0	U-1364/0	U-1355/0
800001692	3	22	48	19	U-0621/0	U-1365/0	U-1356/0
800001693	3	22	63	19	U-0621/0	U-1365/0	U-1356/0
800001694	3	27	48	21	U-0622/0	U-1366/0	U-1357/0
800001695	3	27	63	21	U-0622/0	U-1366/0	U-1357/0
800001696	3	32	63	24	U-0623/0	U-1367/0	U-1358/0
800001697	4	16	55	17	U-0620/0	U-1364/0	U-1355/0
800001698	4	16	70	17	U-0620/0	U-1364/0	U-1355/0
800001699	4	22	55	19	U-0621/0	U-1365/0	U-1356/0
800001700	4	22	70	19	U-0621/0	U-1365/0	U-1356/0
800001701	4	27	55	21	U-0622/0	U-1366/0	U-1357/0
800001702	4	27	70	21	U-0622/0	U-1366/0	U-1357/0
800001703	4	32	55	24	U-0623/0	U-1367/0	U-1358/0
800001704	4	32	70	24	U-0623/0	U-1367/0	U-1358/0
800001705	4	40	70	27	U-0624/0	U-1368/0	U-1359/0
800001706	5	16	75	17	U-0620/0	U-1364/0	U-1355/0
800001707	5	22	75	19	U-0621/0	U-1365/0	U-1356/0
800001708	5	27	75	21	U-0622/0	U-1366/0	U-1357/0
800001709	5	32	75	24	U-0623/0	U-1367/0	U-1358/0
800001710	5	40	75	27	U-0624/0	U-1368/0	U-1359/0
800001711	5	50	75	30	U-0625/0	U-1369/0	U-1360/0

## 7450

■ Frézařské trny pro kotoučové frézy

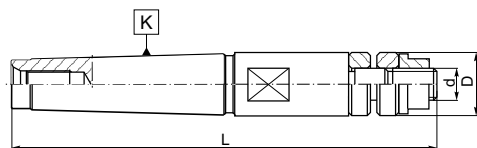

Kód výrobku	Kužel MK	d	D	L
800001712	2	5	10	105,0
800001713	2	8	15	125,0
800001714	2	10	20	135,0
800001715	3	13	25	165,0
800001716	3	16	32	180,0
800001717	4	22	40	215,5
800001718	4	27	50	220,5
800001719	4	32	63	225,5
800001720	4	40	80	235,5
800001721	5	50	100	282,0

## 5310

■ Držáky pro nástrčné výstřižníky

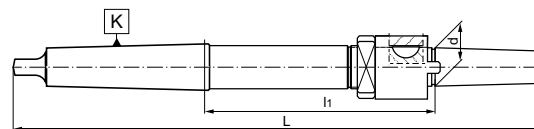

Kód výrobku	Kužel MK	d	L	l <sub>1</sub>			
800000743	2	10	220	105,8	S-0881/0	S-0880/0	U-0097/0
800000744	3	13	250	111,9	S-0884/0	S-0883/0	U-0097/0
800000745	3	16	261	117,9	S-0887/0	S-0886/0	U-0648/0
800000746	3	19	270	121,1	S-0891/0	S-0890/0	U-0098/0
800000747	3	22	278	122,1	S-0894/0	S-0893/0	U-0098/0
800000748	4	19	298	125,6	S-0891/0	S-0890/0	U-0098/0
800000749	4	22	312	132,6	S-0894/0	S-0893/0	U-0098/0
800000750	4	27	325	137,6	S-0897/0	S-0896/0	S-0898/0
800000751	4	32	345	148,9	S-0901/0	S-0900/0	U-0649/0
800000752	5	27	359	139,6	S-0897/0	S-0896/0	S-0898/0
800000753	5	32	376	147,9	S-0901/0	S-0900/0	U-0649/0
800000754	5	40	396	157,9	S-0905/0	S-0904/0	U-0650/0
800000755	5	50	416	167,9	S-0909/0	S-0908/0	U-0106/0

## 6610

■ Soustružnické trny s rozpěrnými pouzdry - sada

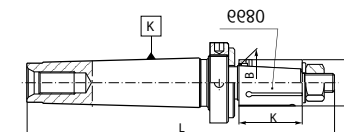

Kód výrobku	Kužel MK	D	L	B	K	Pouzdra obsažená v sadě
800000904	3	12-14	141	9,7	22	12; 13; 14
800000905	3	15-18	150	11,7	27	15; 16; 17; 18
800000906	3	19-22	160	14,7	32	19; 20; 21; 22
800000907	4	23-27	190	17,7	37	23; 24; 25; 26; 27
800000908	4	28-32	200	21,7	42	28; 30; 32
800000909	4	33-38	210	25,6	48	33; 34; 35; 36; 38
800000910	5	40-45	255	31,6	54	40; 42; 44; 45
800000911	5	46-52	265	37,6	60	46; 48; 50; 52
800000912	5	55-60	285	44,5	70	55; 58; 60
800000913	5	63-70	310	51,5	80	63; 65; 68; 70

## 2858

■ Kontrolní trny

■ Verze se stahovací maticí nebo jiná velikost kuželu MK je na poptávku

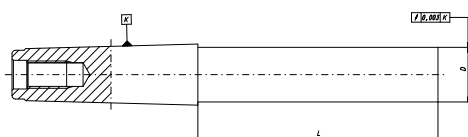

Kód výrobku	Kužel MK	D	L
800006698	4	40	300
800006699	5	50	300

## 6680

■ Rozpěrná pouzdra do držáku 6610 - jednotlivě

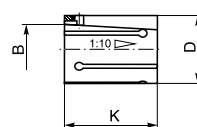

Kód výrobku	D	B	K	Kód výrobku	D	B	K	Kód výrobku	D	B	K
800003516	12	9,7	22	800003531	28	21,7	42	800003539	40	31,6	54
800003517	13	9,7	22	800003532	30	21,7	42	800003540	42	31,6	54
800003518	14	9,7	22	800003533	32	21,7	42	800003541	44	31,6	54
800003519	15	11,7	27	800003534	33	25,6	48	800003542	45	31,6	54
800003520	16	11,7	27	800003535	34	25,6	48	800003543	46	37,6	60
800003521	17	11,7	27	800003536	35	25,6	48	800003544	48	37,6	60
800003522	18	11,7	27	800003537	36	25,6	48	800003545	50	37,6	60
800003523	19	14,7	32	800003538	38	25,6	48	800003546	52	37,6	60
800003527	20	14,7	32	800003539	40	31,6	54	800003547	55	44,5	70
800003524	21	14,7	32	800003540	42	31,6	54	800003548	58	44,5	70
800003525	22	14,7	32	800003541	44	31,6	54	800003549	60	44,5	70
800003526	23	17,7	37	800003542	45	31,6	54	800003550	63	51,5	80
800003527	24	17,7	37	800003543	46	37,6	60	800003551	65	51,5	80
800003528	25	17,7	37	800003544	48	37,6	60	800003552	68	51,5	80
800003529	26	17,7	37	800003545	50	37,6	60	800003553	70	51,5	80
800003530	27	17,7	37	800003546	52	37,6	60				

1  
2  
3  
4  
5  
6  
7

## 1721

■ Držáky rychloupínací

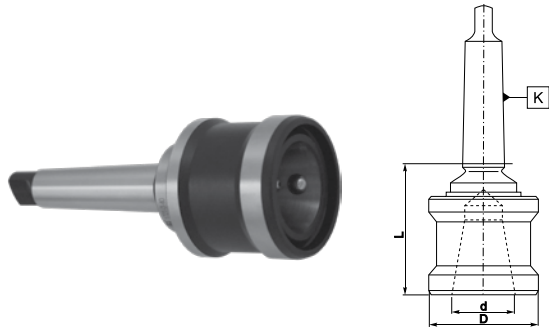

Kód výrobku	Velikost	Kužel MK	d	D	L
800000287	2-40	2	40,0	65	82,5
800000288	3-40	3	40,0	65	81,0
800000289	4-40	4	40,0	65	80,0
800000290	4-51	4	51,5	83	102,0
800000291	5-51	5	51,5	83	98,5

## 5217

■ Vložky do rychlovýměnných držáků pro nástroje s axiálním nastavením

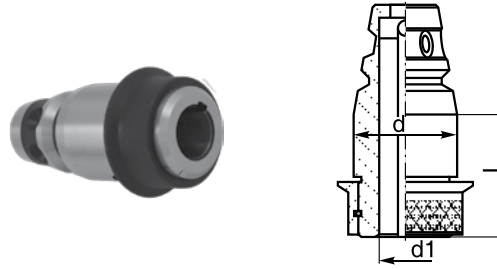

Kód výrobku	Velikost	d	d <sub>1</sub>	L
800000738	40-20	40,0	20	54
800000739	51-28	51,5	28	55

## 5366

■ Vložky do rychlovýměnných držáků pro vrtací sklíčidla

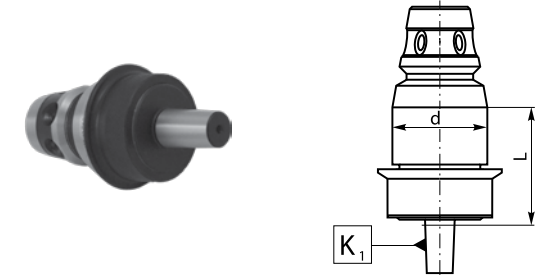

Kód výrobku	Velikost	d	K <sub>1</sub> DIN	L
800000844	40-B12	40,0	B12	32,5
800000845	40-B16	40,0	B16	34,0
800000846	51-B16	51,5	B16	39,0

## 5216

■ Vložky do rychlovýměnných držáků s kuželem morse

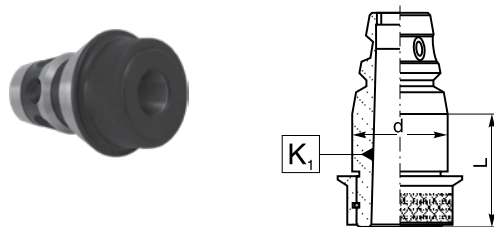

Kód výrobku	Velikost	d	K, MK	L
800000731	40-1	40,0	1	29
800000732	40-2	40,0	2	29
800000733	40-3	40,0	3	47
800000734	51-1	51,5	1	34
800000735	51-2	51,5	2	34
800000736	51-3	51,5	3	34
800000737	51-4	51,5	4	57

## 5219

■ Vložky do rychlovýměnných držáků volná pro výstružníky

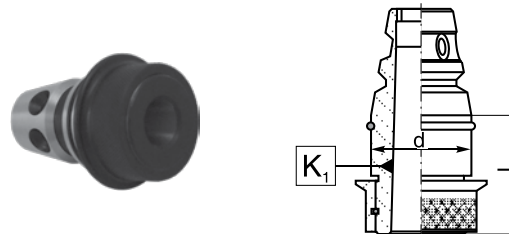

Kód výrobku	Velikost	d	K, MK	L
800000740	40-2	40,0	2	29
800000741	40-3	40,0	3	47
800000742	51-4	51,5	4	57

## 5367

■ Vložky do rychlovýměnných držáků s hrotem

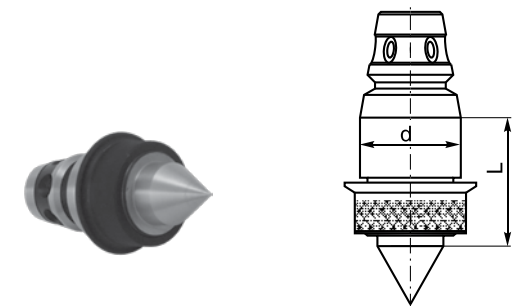

Kód výrobku	Velikost	d	L
800000847	40-60	40,0	61
800000848	51-60	51,5	66

## DIN 1835

- Materiál: legovaná ocel chrom-manganová
- Cementováno do hloubky 0,7mm
- Kaleno a přesně broušeno
- Tvrdost povrchů 58±2 HRC

### DIN 1835-A

- Typ A - hladká stopka



### DIN 1835-B

- Typ B - s jednou ploškou (Weldon)
- $d = 6 \div 20$  mm

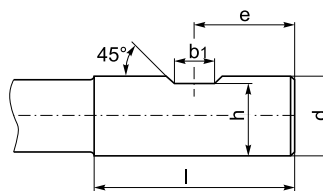

- Typ B - se dvěma ploškami (Weldon)
- $d = 25 \div 32$  mm

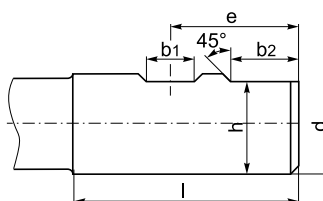

d h6	l	b <sub>1</sub>	b <sub>2</sub>	h h <sub>11</sub>	e
6	36	4,2	-	5,1	18,0
8	36	5,5	-	6,9	18,0
10	40	7,0	-	8,5	20,0
12	45	8,0	-	10,4	22,5
14	45	8,0	-	12,7	22,5
16	48	10,0	-	14,2	24,0
18	48	10,0	-	16,2	24,0
20	50	11,0	-	18,2	25,0
25	56	12,0	17	23,0	32,0
32	60	14,0	19	30,0	35,0

## 7812

- Kleštinové upínače s hladkou stopkou pro kleštiny ER (DIN 6499)

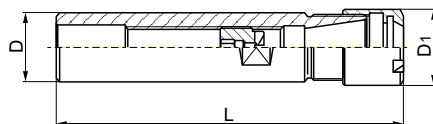

Kód výrobku	D	Kleština	L	Rozsah upínání	D <sub>1</sub>		
800002706	16	ER16	160	2-10	22	9833-16S	M10x11LH
800002707	20	ER16	100	2-10	22	9833-16S	M12x1,5x14LH
800002708	20	ER16	160	2-10	22	9833-16S	M12x1,5x14LH

Nekatalogové rozměry jsou dostupné na objednávku.

Například:

- ER11Mini v různých délkách
- ER20Mini v různých délkách
- ER25Mini v různých délkách
- ER20 v různých délkách
- ER20 v různých délkách
- ER32 v různých délkách
- ER40 v různých délkách

## 7812-KPL

- Kleštinové upínače pro kleštiny ER (DIN 6499) se sadou kleštin



Kód výrobku	D	Kleštiny	L	Rozsah upínání	Počet kleštin v sadě
800002709	16	ER16	160	2-10	8
800002710	20	ER16	100	2-10	8
800002711	20	ER16	160	2-10	8



1  
2  
3  
4  
5  
6  
7

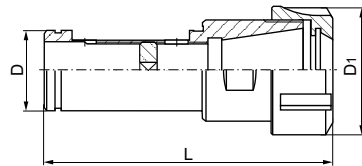
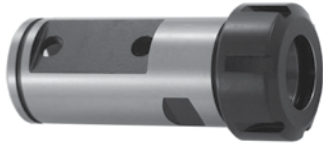

## 7815

■ Kleštinové upínače pro kleštiny ER (DIN 6499)





Kód výrobku	D	Kleština	L	Rozsah upínání	D <sub>1</sub>		
800002717	32	ER32	110	2-20	50	9833-32	M22x1,5x10LH
800002718	40	ER32	117	2-20	50	9833-32	M22x1,5x10LH

■ Jiné rozměry na poptávku !

## 7622

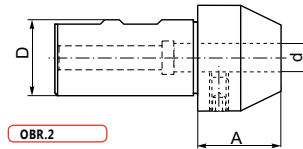
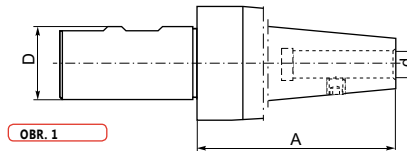
■ Frézařské trny pro nástroje s válčovou stopkou dle DIN 1835-B (WELDON)



Kód výrobku	D	d	A	Obr.	
800001982	20	6	30	2	U-4131/0
800001983	20	8	30	2	U-4132/0
800001984	20	10	30	2	U-4133/0
800001985	20	12	35	2	U-4134/0
800001986	32	6	25	2	U-4131/0
800001987	32	8	25	2	U-4132/0
800001988	32	10	30	2	U-4133/0
800001989	32	12	35	2	U-4134/0
800001990	32	14	40	2	U-4134/0
800001991	32	16	40	2	U-4135/0
800001992	32	18	40	2	U-4136/0
800001993	32	20	40	2	U-4136/0
800001994	40	8	175	1	U-7381/0
800001995	40	10	175	1	U-7381/0
800001996	40	12	175	1	U-7381/0
800001997	40	16	175	1	S-2628/0
800001998	40	20	175	1	S-2628/0
800001999	40	25	175	1	S-2628/0
800002000	40	32	180	1	S-2628/0

## 8500

■ Soustružnické trny

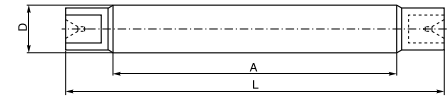

Kód výrobku	D	A	L	Kód výrobku	D	A	L
800002757	3	36	55	800002794	42	187	245
800002758	3,2	45	65	800002795	44	187	245
800002759	3,5	45	65	800002796	45	199	265
800002760	4	45	65	800002797	46	199	265
800002761	4,5	50	70	800002798	48	199	265
800002762	5	50	70	800002799	50	199	265
800002763	6	50	70	800002800	52	231	305
800002764	7	65	85	800002801	54	231	305
800002765	8	65	85	800002802	55	231	305
800002766	9	71	95	800002803	56	231	305
800002767	10	71	95	800002804	58	231	305
800002768	11	87	115	800002805	60	231	305
800002769	12	87	115	800002806	62	248	330
800002770	13	87	115	800002807	63	248	330
800002771	14	87	115	800002808	65	248	330
800002772	15	96	130	800002809	68	248	330
800002773	16	96	130	800002810	70	248	330
800002774	17	96	130	800002811	71	266	360
800002775	18	96	130	800002812	72	266	360
800002776	19	124	160	800002813	75	266	360
800002777	20	124	160	800002814	78	266	360
800002778	21	124	160	800002815	80	266	360
800002779	22	124	160	800002816	82	298	400
800002780	23	130	170	800002817	85	298	400
800002781	24	130	170	800002818	88	298	400
800002782	25	130	170	800002819	90	298	400
800002783	26	130	170	800002820	92	316	430
800002784	27	137	185	800002821	95	316	430
800002785	28	137	185	800002822	98	316	430
800002786	30	137	185	800002823	100	316	430
800002787	32	170	220				
800002788	34	170	220				
800002789	35	178	230				
800002790	36	178	230				
800002791	37	178	230				
800002792	38	178	230				
800002793	40	187	245				

■ Jiné rozměry na poptávku !

## DIN 6327

- Materiál: legovaná ocel chrom-manganová
- Cementováno do hloubky 0,7mm
- Kaleno a přesně broušeno
- Tvrdost povrchů 58±2 HRC

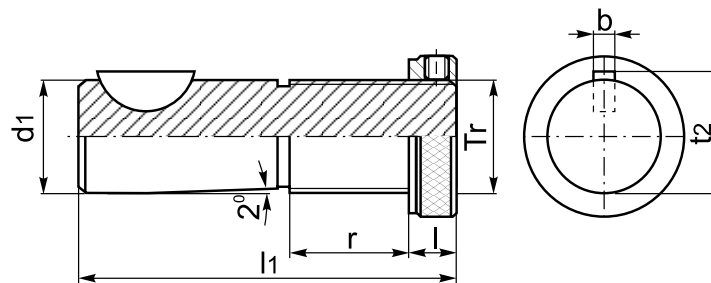

Tr	d <sub>1</sub>	l <sub>1</sub>	l	r	b	t <sub>2</sub>
Tr 16x1,5	16	85	12	28	5	17,1
Tr 20x2	20	88	12	28	5	21,1
Tr 28x2	28	95	12	30	6	29,5
Tr 36x2	36	118	14	36	8	37,5
Tr 48x2	48	144	18	47	10	49,9

## 7813

- Kleštinové upínače pro kleštiny ER (DIN 6499)

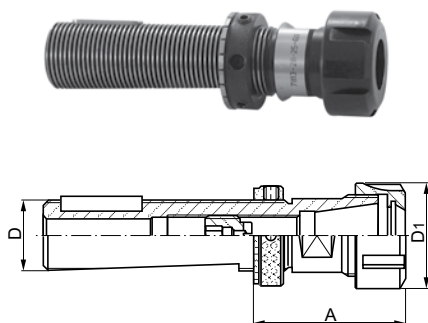

Kód výrobku	D	Kleština	A	Rozsah upínání	D <sub>1</sub>		
800002712	28	ER25	60	2-16	42	9833-25	M16x1,5x17LH
800002713	28	ER32	70	2-20	50	9833-32	M16x1,5x17LH
800002714	36	ER32	65	2-20	50	9833-32	M18x1,5x19LH
800002715	36	ER40	78	3-26	63	9833-40	M18x1,5x19LH
800002716	48	ER40	82	3-26	63	9833-40	M18x1,5x19LH

## 7510

- Frézařské trny univerzální

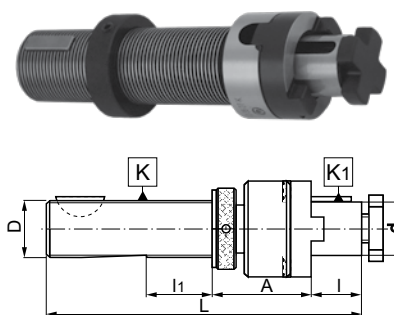

Kód výrobku	K D	K <sub>1</sub> d	L	l <sub>1</sub>	A	l			
800001722	20	16	133	20	50	17	U-0620/0	U-1364/0	Z-1276/0
800001723	20	22	138	20	50	19	U-0621/0	U-1365/0	Z-1276/0
800001724	28	16	140	30	50	17	U-0620/0	U-1364/0	Z-1278/0
800001725	28	22	145	30	50	19	U-0621/0	U-1365/0	Z-1278/0
800001726	28	27	155	30	50	21	U-0622/0	U-1366/0	Z-1278/0
800001727	28	32	155	30	50	24	U-0623/0	U-1367/0	Z-1278/0
800001728	36	16	165	36	50	17	U-0620/0	U-1364/0	Z-1279/0
800001729	36	22	170	36	50	19	U-0621/0	U-1365/0	Z-1279/0
800001730	36	27	175	36	50	21	U-0622/0	U-1366/0	Z-1279/0
800001731	36	32	180	36	50	24	U-0623/0	U-1367/0	Z-1279/0
800001732	48	16	190	47	50	17	U-0620/0	U-1364/0	Z-1280/0
800001733	48	22	195	47	50	19	U-0621/0	U-1365/0	Z-1280/0
800001734	48	27	200	47	50	21	U-0622/0	U-1366/0	Z-1280/0
800001735	48	32	205	47	50	24	U-0623/0	U-1367/0	Z-1280/0
800001736	48	40	210	47	50	27	U-0624/0	U-1368/0	Z-1280/0

## 7520

■ Frézařské trny pro frézy s příčnou unášecí drážkou

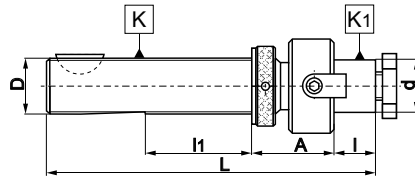

Kód výrobku	K D	K <sub>1</sub> d	L	l <sub>1</sub>	A	I		
800001737	28	16	140	30	36	17	U-0620/0	Z-1278/0
800001738	28	22	142	30	36	19	U-0621/0	Z-1278/0
800001739	28	27	144	30	36	21	U-0622/0	Z-1278/0
800001740	28	32	149	30	38	24	U-0623/0	Z-1278/0
800001741	36	16	163	36	38	17	U-0620/0	Z-1279/0
800001742	36	22	165	36	38	19	U-0621/0	Z-1279/0
800001743	36	27	167	36	38	21	U-0622/0	Z-1279/0
800001744	36	32	172	36	40	24	U-0623/0	Z-1279/0
800001745	48	16	189	47	42	17	U-0620/0	Z-1280/0
800001746	48	22	191	47	42	19	U-0621/0	Z-1280/0
800001747	48	27	193	47	42	21	U-0622/0	Z-1280/0
800001748	48	32	198	47	44	24	U-0623/0	Z-1280/0
800001749	48	40	202	47	45	27	U-0624/0	Z-1280/0

## 1830

■ Redukční pouzdra pro nástroje s kuzelem Morse

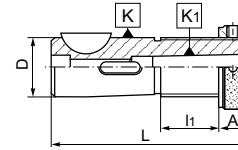

Kód výrobku	K D	K <sub>1</sub> MK	L	l <sub>1</sub>	A	
800000485	16	1	85	28	12	Z-1275/0
800000486	20	1	88	28	12	Z-1276/0
800000487	28	1	95	30	12	Z-1278/0
800000488	28	2	95	30	12	Z-1278/0
800000489	36	1	118	36	14	Z-1279/0
800000490	36	2	118	36	14	Z-1279/0
800000491	36	3	118	36	14	Z-1279/0
800000492	48	1	144	47	18	Z-1280/0
800000493	48	2	144	47	18	Z-1280/0
800000494	48	3	144	47	18	Z-1280/0
800000495	48	4	144	47	18	Z-1280/0

## 1831

■ Redukční pouzdra pro nástroje s kuzelem Morse

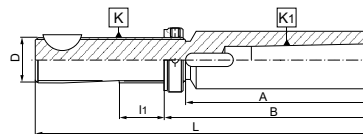

Kód výrobku	K D	K <sub>1</sub> MK	L	A	l <sub>1</sub>	B	
800000496	16	1	164	79	28	91	Z-1275/0
800000497	16	2	179	94	28	106	Z-1275/0
800000498	20	2	182	94	28	106	Z-1276/0
800000499	28	3	212	117	30	129	Z-1278/0
800000500	36	4	264	146	36	160	Z-1279/0

## 1833

■ Redukční pouzdra pro nástroje s kuzelem Morse

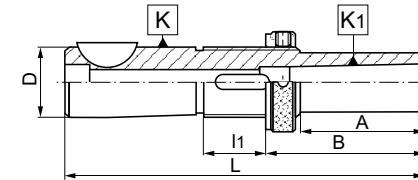

Kód výrobku	K D	K <sub>1</sub> MK	A	L	l <sub>1</sub>	B	
800000501	16	1	25	110	28	37	Z-1275/0
800000502	16	1	50	135	28	62	Z-1275/0
800000503	16	1	75	135	28	87	Z-1275/0
800000504	16	1	100	185	28	112	Z-1275/0
800000505	20	1	25	135	28	37	Z-1276/0
800000506	20	1	50	138	28	62	Z-1276/0
800000507	20	1	75	163	28	87	Z-1276/0
800000508	20	1	100	188	28	112	Z-1276/0
800000509	28	1	25	120	30	37	Z-1278/0
800000510	28	1	50	145	30	62	Z-1278/0
800000511	28	1	75	170	30	87	Z-1278/0
800000512	28	1	100	195	30	112	Z-1278/0
800000513	28	2	25	120	30	37	Z-1278/0
800000514	28	2	50	145	30	62	Z-1278/0
800000515	28	2	75	170	30	87	Z-1278/0
800000516	28	2	100	195	30	112	Z-1278/0
800000517	36	2	30	148	36	44	Z-1279/0
800000518	36	2	60	178	36	74	Z-1279/0
800000519	36	2	90	208	36	104	Z-1279/0
800000520	36	2	120	238	36	134	Z-1279/0
800000521	36	3	30	148	36	44	Z-1279/0
800000522	36	3	60	178	36	74	Z-1279/0
800000523	36	3	90	208	36	104	Z-1279/0
800000524	36	3	120	238	36	134	Z-1279/0
800000525	48	3	40	184	47	58	Z-1280/0
800000526	48	3	80	224	47	98	Z-1280/0
800000527	48	3	120	264	47	138	Z-1280/0
800000528	48	3	160	304	47	178	Z-1280/0
800000529	48	4	40	184	47	58	Z-1280/0
800000530	48	4	80	224	47	98	Z-1280/0
800000531	48	4	120	264	47	138	Z-1280/0
800000532	48	4	160	304	47	178	Z-1280/0

## 5133

■ Vrtací sklíčidlo samosvorné pro konvenční a CNC stroje

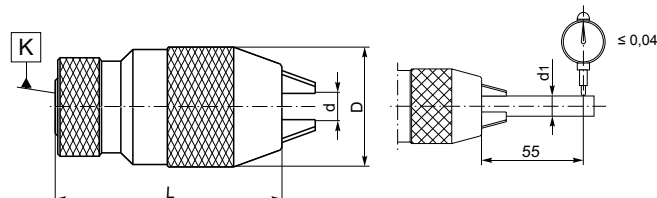

Házivost max.	Kód výrobku	Házivost max.	Kód výrobku	d max	K	Rozsah upínání	D	L	d <sub>1</sub>
Přesné		Standardní							
0,04	80000693	0,15	80000694	10	B12	0,5-10	43	84	6; 10
0,04	80000699	0,15	80000700	10	J2	0,5-10	43	84	6; 11
0,04	80000701	0,15	80000702	10	J33	0,5-10	43	84	6; 12
0,04	80000695	0,15	80000696	13	B12	1-13	50	95	6; 13
0,04	80000697	0,15	80000698	13	B16	1-13	50	95	6; 14
0,04	80000703	0,15	80000704	13	J2	1-13	50	95	6; 15
0,04	80000705	0,15	80000706	13	J6	1-13	50	95	6; 16
0,04	80000707	0,15	80000708	13	J33	1-13	50	95	6; 17
0,04	80000709	0,15	80000710	16	B16	3-16	58	103	6; 16
0,04	80000711	0,15	80000712	16	B18	3-16	58	109	6; 17
0,04	80000713	0,15	80000714	16	J6	3-16	58	103	6; 18
0,04	80000715	0,15	80000716	16	J3	3-16	58	109	6; 19

## 5134

■ Vrtací sklíčidlo samosvorné pro konvenční stroje

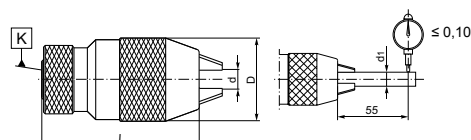

Kód výrobku	d max	K	Rozsah upínání	D	L	d <sub>1</sub>
800000720	10	B12	0,5-10	40	85,5	6; 10
800000721	10	B16	0,5-10	40	85,5	6; 10
800000722	10	1/2"-20	0,5-10	40	94,5	6; 10
800000723	13	B12	1-13	43	84,5	6; 13
800000724	13	B16	1-13	43	84,5	6; 13
800000725	13	3/8"-24	1-13	43	93,5	6; 13
800000726	13	1/2"-20	1-13	43	93,5	6; 13
800000727	16	B16	3-16	50	94,5	6; 16
800000728	16	B18	3-16	50	100,5	6; 16
800000729	16	1/2"20	3-16	50	103,5	6; 16
800000730	16	5/8"-16	3-16	50	103,5	6; 16

## 5363

■ Trny pro vrtací sklíčidla DIN 238 / se závitem

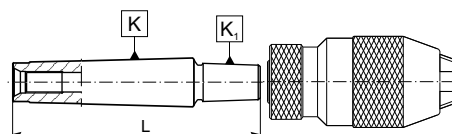

Kód výrobku	Kužel MK	K <sub>1</sub> DIN	L
800000829	2	B12	95
800000830	2	B16	101
800000831	3	B16	121
800000832	4	B16	143

## 5361

■ Trny pro vrtací sklíčidla s kuzelem dle DIN 238 s unašečem

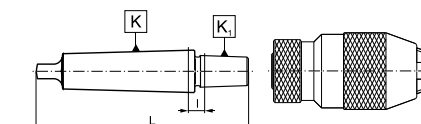

Kód výrobku	Kužel MK	K <sub>1</sub> DIN	L	I
800000773	1	B10	86,0	6,0
800000774	1	B12	89,0	5,0
800000775	1	B16	99,0	8,0
800000776	1	B18	107,0	8,0
800003435	1	B18V	97,0	8,0
800000777	2	B10	105,0	12,0
800000778	2	B12	106,0	9,0
800000779	2	B16	112,0	8,0
800000780	2	B18	119,0	7,0
800003436	2	B18V	108,5	6,5
800000781	2	B22	130,0	9,5
800000782	3	B10	121,0	9,0
800000783	3	B12	127,0	11,0
800000784	3	B16	134,0	11,0
800000785	3	B18	140,0	9,0
800003437	3	B18V	132,0	11,0
800000786	3	B22	147,0	17,5
800000787	3	B24	157,0	17,5
800000788	4	B12	152,5	13,0
800000789	4	B16	158,0	11,5
800000790	4	B18	166,5	12,0
800003438	4	B18V	159,0	14,5
800000791	4	B22	176,0	13,0
800000792	4	B24	186,0	13,0
800000793	5	B12	186,5	15,0
800000794	5	B16	193,0	14,5
800000795	5	B18	200,5	14,0
800003439	5	B18V	191,0	14,5
800000796	5	B22	208,5	13,5
800000797	5	B24	221,0	16,0

1  
2  
3  
4  
5  
6  
7

### 5362

■ Trny pro vrtací sklíčidla s kuzelem Jacobs s unašečem

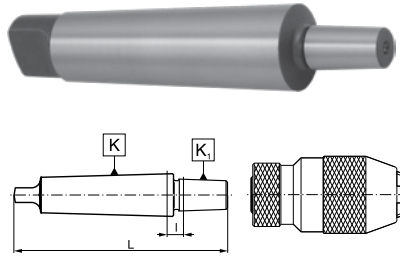

Kód výrobku	Kužel MK	K, Jacobs	L	l
80000798	1	J0	80,5	7,4
80000799	1	J1	83,8	5,1
80000800	1	J2	90,5	6,3
80000801	1	J3	100,5	7,5
80000802	1	J33	95,0	7,6
80000803	1	J6	95,0	7,6
80000804	2	J0	95,5	9,5
80000805	2	J1	102,5	9,8
80000806	2	J2	106,0	8,8
80000807	2	J3	112,5	6,5
80000808	2	J33	107,0	6,6
80000809	2	J4	128,5	11,4
80000810	2	J6	107,0	6,6
80000817	3	J1	120,5	9,8
80000811	3	J2	127,0	10,8
80000812	3	J3	131,5	6,5
80000813	3	J33	126,0	6,6
80000814	3	J4	146,0	10,0
80000815	3	J5	153,0	11,4
80000816	3	J6	129,0	9,6
80000818	4	J2	151,5	11,8
80000819	4	J3	160,5	12,0
80000820	4	J33	155,0	12,0
80000821	4	J4	170,0	10,4
80000822	4	J5	175,5	10,4
80000823	4	J6	155,0	12,0
80000824	5	J3	193,5	12,5
80000825	5	J33	189,5	14,6
80000826	5	J4	203,5	11,4
80000827	5	J5	209,5	12,4
80000828	5	J6	187,0	12,1

### 5374-B

■ Trny DIN 69871 pro vrtací sklíčidla s kuzelem dle DIN 238

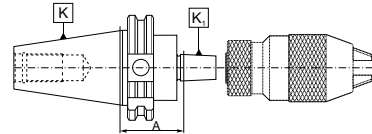

Kód výrobku	K 7:24	K, DIN	A
80000880	30	B12	25
80000881	30	B16	25
80000882	40	B12	40
80000883	40	B12	90
80000884	40	B16	40
80000885	40	B16	90
80000886	40	B18	40
80000887	40	B18	90
80000888	50	B16	40
80000889	50	B16	90
80000890	50	B18	40
80000891	50	B18	90

### 5373-B

■ Trny MAS-BT pro vrtací sklíčidla s kuzelem dle DIN 238

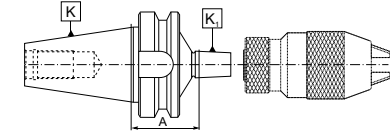

Kód výrobku	K 7:24	K, DIN	A
80000868	30	B12	30
80000869	30	B16	30
80000870	40	B12	40
80000871	40	B12	90
80000872	40	B16	42
80000873	40	B16	90
80000874	40	B18	42
80000875	40	B18	90
80000876	50	B16	45
80000877	50	B16	90
80000878	50	B18	45
80000879	50	B18	90

### 5374-J

■ Trny DIN 69871 pro vrtací sklíčidla s kuzelem Jacobs

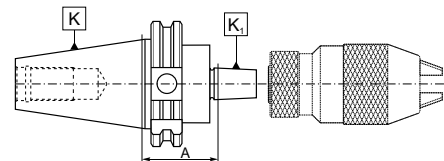

Kód výrobku	K 7:24	K, Jacobs	A
800003387	40	J33	40
800003388	40	J6	40
800003389	50	J33	40
800003390	50	J6	40

### 5373-J

■ Trny MAS-BT pro vrtací sklíčidla s kuzelem Jacobs

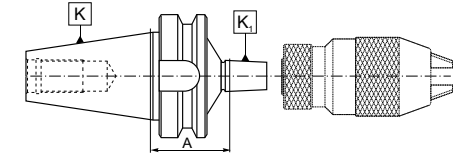

Kód výrobku	K 7:24	K, Jacobs	A
800003391	30	J6	30
800003392	40	J33	42
800003393	40	J6	42
800003394	50	J33	45
800003395	50	J6	45

### 5370-B

■ Trny DIN 2080 pro vrtací sklíčidla s kuzelem dle DIN 238

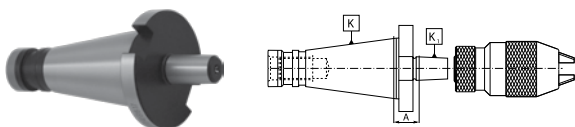

Kód výrobku	K 7:24	K <sub>1</sub> DIN	A
80000849	30	B10	15
80000850	30	B12	15
80000851	30	B16	15
80000852	30	B18	15
80000853	30	B22	15
80000854	40	B12	17
80000855	40	B12	90
80000856	40	B16	17
80000857	40	B16	90
80000858	40	B18	17
80000859	40	B18	90
80000860	40	B22	17
80000861	40	B24	17
80000862	50	B16	20
80000863	50	B16	90
80000864	50	B18	20
80000865	50	B18	90
80000866	50	B22	20
80000867	50	B24	20

### 5390-B

■ Trny DIN 69893-A (HSK) pro vrtací sklíčidla s kuzelem dle DIN 238

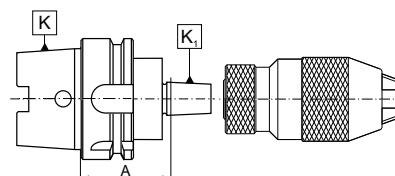

Kód výrobku	K HSK-A	K <sub>1</sub> DIN	A
80000892	63	B12	45
80000893	63	B16	45
80000894	63	B18	45

### 5348

■ Trny s válcovou stopkou pro vrtací sklíčidla s kuzelem dle DIN 238

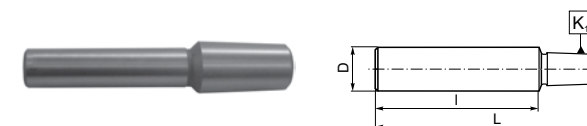

Kód výrobku	D	L	K <sub>1</sub> DIN	L
80000756	8	35	B10	55.5
80000757	10	48	B12	72.5
80000758	10	50	B10	69.5
80000759	10	50	B12	74.5
80000760	10	50	B16	83.5
80000761	12	50	B16	83.5
80000762	12	60	B16	93.5
80000763	16	50	B16	81.0
80000764	16	70	B16	101.0
80000765	16	70	B18	110.0
80000766	20	30	B16	63.0
80000767	20	60	B12	87.0
80000768	20	60	B16	93.0
80000769	20	60	B18	100.0
80000770	25	75	B16	109.0
80000771	30	70	B16	106.0
80000772	30	70	B18	112.0

### 5370-J

■ Trny DIN 2080 pro vrtací sklíčidla s kuzelem Jacobs

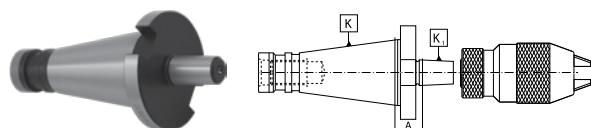

Kód výrobku	K 7:24	K <sub>1</sub> Jacobs	A
800003406	30	J0	12
800003407	30	J1	12
800003408	30	J2	12
800003409	30	J3	12
800003410	30	J33	12
800003411	30	J6	12
800003412	40	J2	14
800003414	40	J3	14
800003413	40	J33	14
800003415	40	J6	14
800003416	50	J3	18
800003417	50	J33	18
800003418	50	J4	18
800003419	50	J5	18
800003420	50	J6	18

### 5390-J

■ Trny DIN 69893-A (HSK) pro vrtací sklíčidla s kuzelem Jacobs

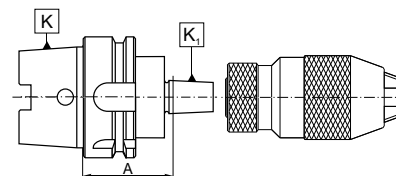

Kód výrobku	K HSK-A	K <sub>1</sub> DIN	A
80000895	63	J1	45
80000896	63	J2	45
80000897	63	J3	45
80000898	63	J33	45
80000899	63	J4	45
80000900	63	J5	45

### 5365

■ Trny s axiálním nastavením pro vrtací sklíčidla s kuzelem dle DIN 238

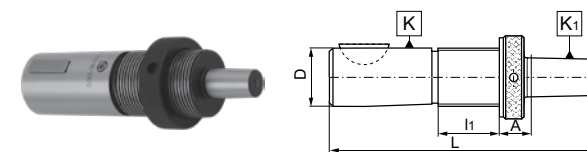

Kód výrobku	K D	K <sub>1</sub> DIN	L	l <sub>1</sub>	A	Ø
80000833	20	B12	110	28	4.5	Z-1276/0
80000834	20	B16	117	28	5.0	Z-1276/0
80000835	28	B12	118	30	4.5	Z-1278/0
80000836	28	B16	124	30	5.0	Z-1278/0
80000837	28	B18	132	30	5.0	Z-1278/0
80000838	36	B16	147	36	5.0	Z-1279/0
80000839	36	B18	155	36	5.0	Z-1279/0
80000840	36	B22	163	36	4.5	Z-1279/0
80000841	48	B16	173	47	5.0	Z-1280/0
80000842	48	B18	181	47	5.0	Z-1280/0
80000843	48	B22	189	47	4.5	Z-1280/0

1  
2  
3  
4  
5  
6  
7

## 1751

■ Redukční pouzdra pro nástroje se stopkou Morse

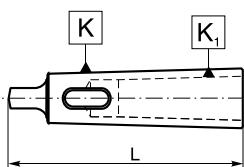

Kód výrobku	Kužel MK	K <sub>1</sub> MK	L
800000292	1	0	85
800000293	2	1	92
800000294	3	1	99
800000295	3	2	112
800000296	4	1	124
800000297	4	2	124
800000298	4	3	140
800000299	5	1	156
800000300	5	2	156
800000301	5	3	156
800000302	5	4	174
800000303	6	2	218
800000304	6	3	218
800000305	6	4	218
800000306	6	5	218

## 1754

■ Redukční pouzdra pro nástroje se stopkou Morse se stahovací maticí

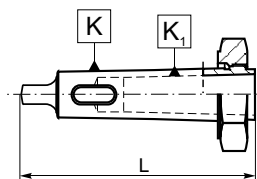

Kód výrobku	Kužel MK	K <sub>1</sub> MK	L	
800000322	2	1	92,0	S-0776/0
800000323	3	1	119,0	S-0778/0
800000324	3	2	119,0	S-0778/0
800000325	4	1	146,5	S-0778/0
800000326	4	2	146,5	S-0778/0
800000327	4	3	146,5	S-0778/0
800000328	5	2	178,0	S-0782/0
800000329	5	3	178,0	S-0782/0
800000330	5	4	178,0	S-0782/0
800000331	6	3	245,0	S-0784/0
800000332	6	4	245,0	S-0784/0
800000333	6	5	245,0	S-0784/0

## 1770

■ Redukční pouzdra vřetenová pro nástroje se stopkou Morse

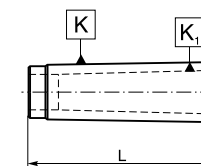

Kód výrobku	Kužel MK	K <sub>1</sub> MK	L
800000450	2	1	50
800000451	3	1	55
800000452	3	2	65
800000453	4	2	70
800000454	4	3	75
800000455	5	2	80
800000456	5	3	90
800000457	5	4	100
800000458	6	3	110
800000459	6	4	120
800000460	6	5	130

Kód výrobku	K Metrický	K <sub>1</sub> MK	L
800006617	50	4	*
800000461	80	5	135
800000462	80	6	170
800003999	100	5	180
800000463	100	6	180

## 1774

- Redukční pouzdra pro nástroje s kuželem Morse se závitem se stahovací maticí

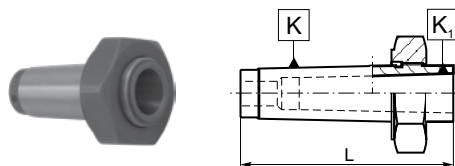

Kód výrobku	Kužel MK	K, MK	L
80000464	3	2	80
80000465	4	2	86
80000466	4	3	91
80000467	5	2	102
80000468	5	3	112
80000469	5	4	122
80000470	6	3	137
80000471	6	4	147
80000472	6	5	157

## 1775

- Redukční pouzdra pro nástroje se stopkou Morse s unašečem se stahovací maticí

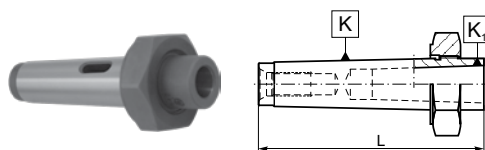

Kód výrobku	Kužel MK	K, MK	L	Ø
80000473	2	1	100,0	S-0776/0
80000474	3	1	112,0	S-0778/0
80000475	3	2	125,0	S-0778/0
80000476	4	1	135,5	S-0778/0
80000477	4	2	147,0	S-0778/0
80000478	4	3	165,0	S-0778/0
80000479	5	2	160,0	S-0782/0
80000480	5	3	167,0	S-0782/0
80000481	5	4	171,5	S-0782/0
80000482	6	3	217,0	S-0784/0
80000483	6	4	217,0	S-0784/0
80000484	6	5	217,0	S-0784/0

## 1761

- Redukční pouzdra pro nástroje se stopkou Morse

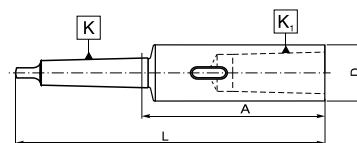

Kód výrobku	Kužel MK	K, MK	L	A	D
80000334	1	1	145	83,0	20
80000335	1	2	160	98,0	30
80000336	1	3	183	121,0	36
80000337	2	1	160	85,0	20
80000338	2	2	175	100,0	30
80000339	2	3	196	121,0	36
80000340	2	4	221	146,0	48
80000341	3	1	175	81,0	20
80000342	3	2	194	100,0	30
80000343	3	3	215	121,0	36
80000344	3	4	240	146,0	48
80000345	3	5	275	181,0	63
80000346	4	1	200	82,5	20
80000347	4	2	215	97,5	30
80000348	4	3	240	122,5	36
80000349	4	4	265	147,5	48
80000350	4	5	300	182,5	63
80000351	4	6	361	243,5	82
80000352	5	1	232	82,5	20
80000353	5	2	247	97,5	30
80000354	5	3	268	118,5	36
80000355	5	4	300	150,5	48
80000356	5	5	335	185,5	63
80000357	5	6	396	246,5	82
80000358	6	1	294	84,0	20
80000359	6	2	309	99,0	30
80000360	6	3	330	120,0	36
80000361	6	4	355	145,0	48
80000362	6	5	390	180,0	63
80000363	6	6	451	241,0	82

## 1764

- Prodloužovací redukční pouzdra pro nástroje se stopkou Morse

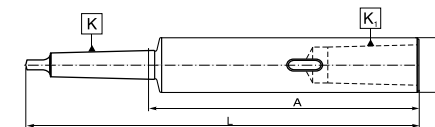

Kód výrobku	Kužel MK	K, MK	L	A	D
80000394	1	1	200	138,0	20
80000395	1	1	250	188,0	20
80000396	1	1	300	238,0	20
80000397	1	1	350	288,0	20
80000398	1	1	400	338,0	20
80000399	1	1	450	388,0	20
80000400	1	1	500	438,0	20
80000401	2	2	200	125,0	25
80000402	2	2	250	175,0	25
80000403	2	2	300	225,0	25
80000404	2	2	350	275,0	25
80000405	2	2	400	325,0	25
80000406	2	2	450	375,0	25
80000407	2	2	500	425,0	25
80000408	2	2	600	525,0	25
80000409	3	3	250	156,0	32
80000410	3	3	300	206,0	32
80000411	3	3	350	256,0	32
80000412	3	3	400	306,0	32
80000413	3	3	450	356,0	32
80000414	3	3	500	406,0	32
80000415	3	3	600	506,0	32
80000416	4	4	300	182,5	40
80000417	4	4	350	232,5	40
80000418	4	4	400	282,5	40
80000419	4	4	450	332,5	40
80000420	4	4	500	382,5	40
80000421	4	4	600	482,5	40

Jiné rozměry jsou na poptávku !

1  
2  
3  
4  
5  
6  
7



## 1226

■ Redukční pouzdra do soustružnických držáků

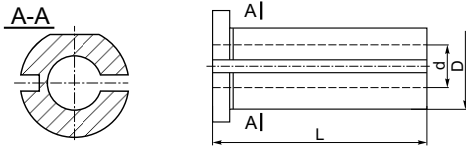

Kód výrobku	D	d	L
800000010	20	8	50
800000016	20	10	50
800000018	20	12	50
800000011	20	8	60
800000017	20	10	60
800000019	20	12	60
800000012	25	8	50
800000020	25	10	50
800000022	25	12	50
800000025	25	16	50
800000015	25	8	60
800000021	25	10	60
800000023	25	12	60
800000026	25	16	60
800000024	25	12	75
800000027	25	16	75
800000037	32	8	60
800000028	32	10	60
800000029	32	12	60
800000031	32	16	60
800000033	32	20	60
800000035	32	25	60
800000030	32	12	75
800000032	32	16	75
800000034	32	20	75
800000036	32	25	75
800000044	40	8	75
800000038	40	10	75
800000039	40	12	75
800000040	40	16	75
800000041	40	20	75
800000042	40	25	75
800000043	40	32	75
800000045	50	12	75
800000046	50	16	75
800000047	50	20	75
800000048	50	25	75
800000049	50	32	75
800000050	50	40	75

## 1246

■ Redukční pouzdra do soustružnických držáků

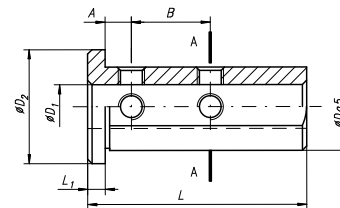

OBR. 1

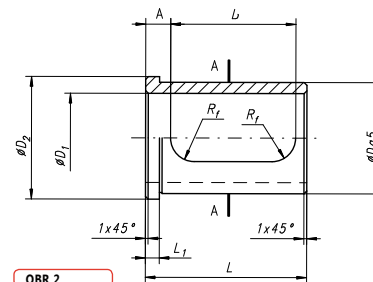
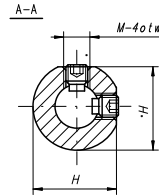

OBR. 2

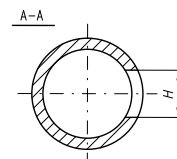

Typ	Kód výrobku	D	D1	D2	L	L1	A	B	Obr.
1246-20-6	800006236		6					14	
1246-20-8	800006237	20	8	26	50	4	6	18	1
1246-20-10	800006238		10					18	
1246-20-12	800006061		12						
1246-20-14	800006062	20	14	26	50	4	7	40	2
1246-20-16	800006063		16						
1246-25-6	800006057		6				8	14	
1246-25-8	800006058		8				7	18	
1246-25-10	800006059	25	10	30	50	4	8	18	1
1246-25-12	800006052		12				8	20	
1246-25-14	800006060		14				8	20	
1246-25-16	800006053	25	16	30	50	4	7	40	2
1246-25-20	800006054		20						
1246-32-6	800006239		6				8	14	
1246-32-8	800006038		8				7	18	
1246-32-10	800005999	32	10	40	58	5	8	18	1
1246-32-12	800006000		12				8	20	
1246-32-14	800006039		14				8	20	
1246-32-16	800006001		16				8	20	
1246-32-20	800006040	32	20	40	58	5	9	45	2
1246-32-25	800006055		25						
1246-40-6	800006240		6				8	14	
1246-40-8	800006002		8				7	18	
1246-40-10	800006003		10				8	18	
1246-40-12	800006231		12				8	20	
1246-40-14	800006241	40	14	44	58	5	8	20	1
1246-40-16	800006232		16				8	20	
1246-40-20	800006233		20				8	20	
1246-40-25	800006234		25				8	20	
1246-40-32	800006065	40	32	44	58	5	9	45	2
1246-50-6	1246-50-6		6				8	14	
1246-50-8	1246-50-8		8				7	18	
1246-50-10	1246-50-10		10				8	18	
1246-50-12	1246-50-12		12				8	20	
1246-50-14	1246-50-14	50	14	58	68	5	8	20	1
1246-50-16	800006747		16				8	20	
1246-50-20	800006748		20				8	20	
1246-50-25	800006749		25				8	20	
1246-50-32	800006750		32				8	20	
1246-50-40	800006751	50	40	58	68	5	9	55	2

1246-60-xx Na poptávku 60 Pouzdra s vnějším průměrem 60mm jsou na poptávku

## 1247

■ Redukční pouzdra do nástrojových držáků VDI

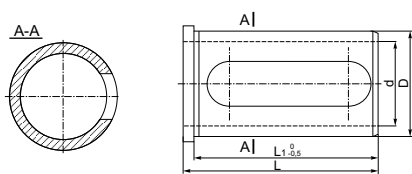

Kód výrobku	D	d	L	L1
800003725	32	10	64	60
800003726	32	12	64	60
800003727	32	16	64	60
800003728	32	20	64	60
800003729	32	25	64	60
800003730	40	10	74	70
800003731	40	12	74	70
800003732	40	16	74	70
800003733	40	20	74	70
800003734	40	25	74	70
800003735	40	32	74	70

## 1248

■ Redukční pouzdra do nástrojových držáků VDI

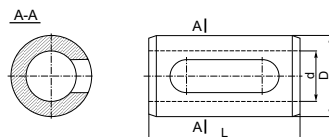
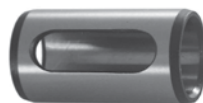

Kód výrobku	D	d	L
800000051	32	12	60
800000052	32	16	60
800000053	32	20	60
800000054	32	25	60

## 1249

■ Redukční pouzdra do nástrojových držáků VDI

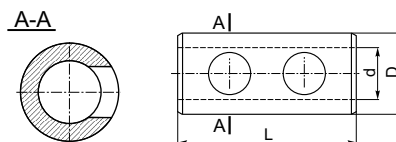
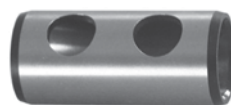

Kód výrobku	D	d	L
800000055	20	8	48
800000056	20	10	48
800000057	20	12	48
800000058	20	16	48
800000059	25	5	55
800000060	25	8	55
800000061	25	10	55
800000062	25	12	55
800000063	25	16	55
800000064	25	18	55
800000065	25	20	55

## 1875

■ Válcová pouzdra pro nástroje s kuzelem Morse

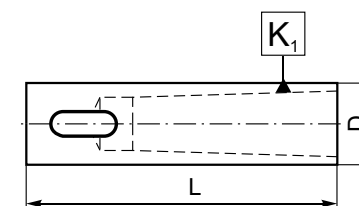

Kód výrobku	D	K, MK	L
800003500	20	1	75
800000533	25	1	75
800000545	25	1	89
800000534	25	2	75
800000546	25	2	100
800000547	32	1	89
800003501	32	1	100
800000535	32	2	100
800000536	32	3	100
800000540	32	3	120
800000548	40	1	89
800003502	40	1	100
800000537	40	2	100
800000538	40	3	100
800000541	40	3	120
800000539	40	4	120
800000542	40	4	152
800000549	50	2	100
800000543	50	3	120
800000544	50	4	152

1  
2  
3  
4  
5  
6  
7

**7618**

- Kleštiny typu ER (DIN 6499)

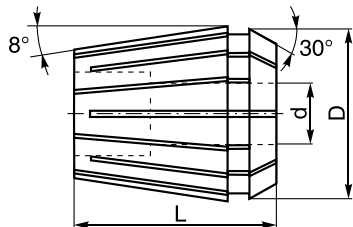
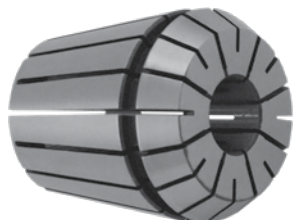
**ER11**

Kód výrobku	Kleština	Rozsah upínání (d)	D	L
800006523	ER11	1,0-0,5	11,5	18
800006524	ER11	1,5-1,0	11,5	18
800006525	ER11	2,0-1,5	11,5	18
800006526	ER11	2,5-5,0	11,5	18
800006527	ER11	3,0-2,5	11,5	18
800006528	ER11	3,5-3,0	11,5	18
800006529	ER11	4,0-3,5	11,5	18
800006530	ER11	4,5-4,0	11,5	18
800006531	ER11	5,0-4,5	11,5	18
800006532	ER11	5,5-5,0	11,5	18
800006533	ER11	6,0-5,5	11,5	18
800006534	ER11	6,5-6,0	11,5	18
800006535	ER11	7,0-6,5	11,5	18

**ER16**

Kód výrobku	Kleština	Rozsah upínání (d)	D	L
na poptávku	ER16	1-0,5	17	27,5
na poptávku	ER16	2-1,5	17	27,5
800001829	ER16	3-2	17	27,5
800001830	ER16	4-3	17	27,5
800001831	ER16	5-4	17	27,5
800001832	ER16	6-5	17	27,5
800001833	ER16	7-6	17	27,5
800001834	ER16	8-7	17	27,5
800001835	ER16	9-8	17	27,5
800001836	ER16	10-9	17	27,5

**ER20**

Kód výrobku	Kleština	Rozsah upínání (d)	D	L
na poptávku	ER20	1-0,5	21	31,5
na poptávku	ER20	2-1,5	21	31,5
800001837	ER20	3-2	21	31,5
800001838	ER20	4-3	21	31,5
800001839	ER20	5-4	21	31,5
800001840	ER20	6-5	21	31,5
800001841	ER20	7-6	21	31,5
800001842	ER20	8-7	21	31,5
800001843	ER20	9-8	21	31,5
800001844	ER20	10-9	21	31,5
800001845	ER20	11-10	21	31,5
800001846	ER20	12-11	21	31,5
800001847	ER20	13-12	21	31,5
na poptávku	ER20	14-13	21	31,5

**ER25**

Kód výrobku	Kleština	Rozsah upínání (d)	D	L
na poptávku	ER25	1-0,5	26	34,0
na poptávku	ER25	2-1,5	26	34,0
800001849	ER25	3-2	26	34,0
800001850	ER25	4-3	26	34,0
800001851	ER25	5-4	26	34,0
800001852	ER25	6-5	26	34,0
800001853	ER25	7-6	26	34,0
800001854	ER25	8-7	26	34,0
800001855	ER25	9-8	26	34,0
800001856	ER25	10-9	26	34,0
800001857	ER25	11-10	26	34,0
800001858	ER25	12-11	26	34,0
800001859	ER25	13-12	26	34,0
800001860	ER25	14-13	26	34,0
800001861	ER25	15-14	26	34,0
800001862	ER25	16-15	26	34,0
na poptávku	ER25	17-16	26	34,0
na poptávku	ER25	18-17	26	34,0
na poptávku	ER25	19-18	26	34,0
na poptávku	ER25	20-19	26	34,0

**Další typy kleštín ER na objednávku:**

- Kleštiny ER s házením do 5µm



- Kleštiny ER utěsněné
- Kleštiny ER utěsněné s kanály (mimo ER11)
- Kleštiny ER utěsněné celokovové (mimo ER11)



- Kleštiny ER s vnitřním čtyřhranem



- Kleštiny ER s pro závitníky s délkovým vyrovnáním (mimo ER11)
- Kleštiny ER s pro výstružníky plovoucí (mimo ER11)



- Kleštiny ER8 a ER50 jsou na poptávku!

**ER32 a ER40 viz další strana -->**

## 7618

■ Kleštiny typu ER (DIN 6499)

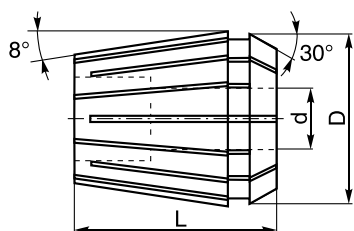
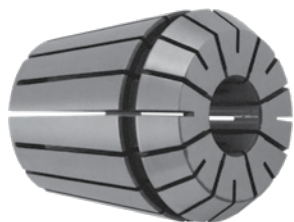

## ER32

Kód výrobku	Kleština	Rozsah upínání (d)	D	L
na poptávku	ER32	2-1,5	33	40,0
800001863	ER32	3-2	33	40,0
800001864	ER32	4-3	33	40,0
800001865	ER32	5-4	33	40,0
800001866	ER32	6-5	33	40,0
800001867	ER32	7-6	33	40,0
800001868	ER32	8-7	33	40,0
800001869	ER32	9-8	33	40,0
800001870	ER32	10-9	33	40,0
800001871	ER32	11-10	33	40,0
800001872	ER32	12-11	33	40,0
800001873	ER32	13-12	33	40,0
800001874	ER32	14-13	33	40,0
800001875	ER32	15-14	33	40,0
800001876	ER32	16-15	33	40,0
800001877	ER32	17-16	33	40,0
800001878	ER32	18-17	33	40,0
800001879	ER32	19-18	33	40,0
800001880	ER32	20-19	33	40,0
na poptávku	ER32	21-20	33	40,0
na poptávku	ER32	22-21	33	40,0

## ER40

Kód výrobku	Kleština	Rozsah upínání (d)	D	L
800001881	ER40	3-2	41	46,0
800001882	ER40	4-3	41	46,0
800001883	ER40	5-4	41	46,0
800001884	ER40	6-5	41	46,0
800001885	ER40	7-6	41	46,0
800001886	ER40	8-7	41	46,0
800001887	ER40	9-8	41	46,0
800001888	ER40	10-9	41	46,0
800001889	ER40	11-10	41	46,0
800001890	ER40	12-11	41	46,0
800001891	ER40	13-12	41	46,0
800001892	ER40	14-13	41	46,0
800001893	ER40	15-14	41	46,0
800001894	ER40	16-15	41	46,0
800001895	ER40	17-16	41	46,0
800001896	ER40	18-17	41	46,0
800001897	ER40	19-18	41	46,0
800001898	ER40	20-19	41	46,0
800001899	ER40	21-20	41	46,0
800001900	ER40	22-21	41	46,0
800001901	ER40	23-22	41	46,0
800001902	ER40	24-23	41	46,0
800001903	ER40	25-24	41	46,0
800001904	ER40	26-25	41	46,0
na poptávku	ER40	27-26	41	46,0
na poptávku	ER40	28-27	41	46,0
na poptávku	ER40	29-28	41	46,0
na poptávku	ER40	30-29	41	46,0

## Další typy kleštin ER na objednávku:

■ Kleštiny ER s házením do 5µm

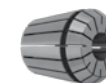

- Kleštiny ER utěsněné
- Kleštiny ER utěsněné s kanály
- Kleštiny ER utěsněné celokovové



■ Kleštiny ER s vnitřním čtyřhranem



- Kleštiny ER s pro závitníky s délkovým vyrovnáním
- Kleštiny ER s pro výstružníky plovoucí



■ Kleštiny ER8 a ER50 jsou na poptávku!

1

2

3

4

5

6

7

## 7618-KPL

■ Sady kleštin typu ER (DIN 6499)



Kód výrobku	Kleština	Rozsah upínání	Počet kleštin v sadě
800001905	ER16	2-10	8
800001906	ER20	2-13	11
800001907	ER25	2-16	14
800001908	ER32	2-20	18
800001909	ER40	2-26	24



## 7600-KPL

## 7600-PL

■ Sady kleštin typu ER (DIN 6499)

Kód výrobku	Velikost	Kužel upínače 7:24	Kleština 7618 ER DIN 6499	7618 ER DIN 6499	Počet kleštin v sadě	Rozsah upínání	A max (max. délka upínače)
800003707	30-16-8-80KPL	30	16-3, 4, 5, 6, 7, 8, 9, 10		8	2-10	80
800003708	30/40-32-8-80PL	30, 40	32-6, 8, 10, 12, 14, 16, 18, 20		8	5-20	80
800003709	30/40-32-8-80PL	30, 40	32-4, 5, 6, 8, 10, 12, 16, 20		8	3-20	80
800003710	30/40-32-18-80KPL	30, 40	32-3, 4, 5, 6, 7, 8, 9, 10, 11, 12, 13, 14, 15, 16, 17, 18, 19, 20		18	2-20	80
800003711	40-16-8-150S	40	16-3, 4, 5, 6, 7, 8, 9, 10		8	2-10	150
800003712	40-25-14-60KPL	40	25-3, 4, 5, 6, 7, 8, 9, 10, 11, 12, 13, 14, 15, 16		14	2-16	60
800003713	40-32-10-70PL	40	32-3, 4, 6, 8, 10, 12, 14, 16, 18, 20		10	2-20	70
800003714	40-32-18-80-130KPL	40	32-3, 4, 5, 6, 7, 8, 9, 10, 11, 12, 13, 14, 15, 16, 17, 18, 19, 20		18	2-20	80-130
800003715	40-40-24-80KPL	40	40-3, 4, 5, 6, 7, 8, 9, 10, 11, 12, 13, 14, 15, 16, 17, 18, 19, 20, 21, 22, 23, 24, 25, 26		24	2-26	80
800006825	50-32-8-70PL	50	32-4, 5, 6, 8, 10, 12, 16, 20		8	3-20	70
800003717	50-32-18-130KPL	50	32-3, 4, 5, 6, 7, 8, 9, 10, 11, 12, 13, 14, 15, 16, 17, 18, 19, 20		18	2-20	130
800003718	50-40-24-130KPL	50	40-3, 4, 5, 6, 7, 8, 9, 10, 11, 12, 13, 14, 15, 16, 17, 18, 19, 20, 21, 22, 23, 24, 25, 26		24	2-26	130
800003716	50-16-8-150S PL	50	16-3, 4, 5, 6, 7, 8, 9, 10		8	2-10	150

KPL - Sada kleštin typu ER (DIN 6499) s prázdným místem pro doplnění vybraným upínačem

PL - Malá sada kleštin typu ER (DIN 6499) s prázdným místem pro doplnění vybraným upínačem

S PL - Sada kleštin typu ER (DIN 6499) s prázdným místem pro doplnění vybraným dlouhým upínačem

### UPÍNÁNÍ NÁSTROJŮ V KLEŠTINÁCH ER

- Do matice vložte kleštinu pod úhlem. Zachyťte drážku kleštiny o excentrický výstupek matice a vtlačte kleštinu do matice
- Vložte kleštinu s maticí do kleštinového upínače
- Do kleštiny vložte nástroj a dotáhněte klíčem matici
- Při vyjímání kleštiny postupujte v obráceném pořadí

## 3000-5C

■ Kleštiny typu 5C (385E)

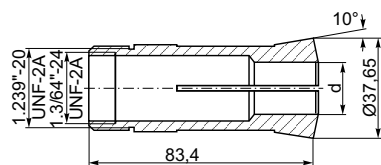

Kód výrobku	Velikost	d
na poptávku	5C-1,0	1
na poptávku	5C-2,0	2
80000604	5C-3,0	3
80000605	5C-3,5	3,5
80000606	5C-4,0	4
80000607	5C-4,5	4,5
80000608	5C-5,0	5
80000609	5C-5,5	5,5
80000610	5C-6,0	6
80000611	5C-6,5	6,5
80000612	5C-7,0	7
80000613	5C-7,5	7,5
80000614	5C-8,0	8
80000615	5C-8,5	8,5
80000616	5C-9,0	9
80000617	5C-9,5	9,5
80000618	5C-10,0	10

Kód výrobku	Velikost	d
80000619	5C-10,5	10,5
80000620	5C-11,0	11
80000621	5C-11,5	11,5
80000622	5C-12,0	12
80000623	5C-12,5	12,5
80000624	5C-13,0	13
80000625	5C-13,5	13,5
80000626	5C-14,0	14
80000627	5C-14,5	14,5
80000628	5C-15,0	15
80000629	5C-15,5	15,5
80000630	5C-16,0	16
80000631	5C-16,5	16,5
80000632	5C-17,0	17
80000633	5C-17,5	17,5
80000635	5C-18,5	18,5
80000636	5C-19,0	19
80000637	5C-19,5	19,5
80000638	5C-20,0	20
80000639	5C-20,5	20,5
80000640	5C-21,0	21
80000641	5C-21,5	21,5
80000642	5C-22,0	22
80000643	5C-22,5	22,5
80000644	5C-23,0	23
80000645	5C-23,5	23,5
80000646	5C-24,0	24
80000647	5C-24,5	24,5
80000648	5C-25,0	25
80005510	5C-25,5	25,5
80003724	5C-26,0	26
na poptávku	5C-27,0	27

■ Jiné průměry nebo jiný profil (čtyřhran, šestihran, atd.) jsou na poptávku!



## 3000-5C KPL

■ Kleštiny typu 5C (385E) - sady



Kód výrobku	Kleština	Rozsah upínání	Počet kleštin v sadě
80000649	5C	3-26	24 (sada po 1mm)
80000650	5C	3-25	45 (sada po 0,5mm)

1

2

3

4

5

6

7

**Profil kleštiny  
hladký  
EG**



Kód výrobku	Typ	D <sub>1</sub>	D <sub>2</sub>	L	d
800006787	171E- 3 EG	42	55	94	3
800006788	171E- 4 EG	42	55	94	4
800006789	171E- 5 EG	42	55	94	5
800006790	171E- 6 EG	42	55	94	6
800006791	171E- 7 EG	42	55	94	7
800006792	171E- 8 EG	42	55	94	8
Na poptávku	171E- 9 EG	42	55	94	9
Na poptávku	171E-10 EG	42	55	94	10
Na poptávku	171E-11 EG	42	55	94	11
Na poptávku	171E-12 EG	42	55	94	12
Na poptávku	171E-13 EG	42	55	94	13
Na poptávku	171E-14 EG	42	55	94	14
Na poptávku	171E-15 EG	42	55	94	15
Na poptávku	171E-16 EG	42	55	94	16
Na poptávku	171E-17 EG	42	55	94	17
Na poptávku	171E-18 EG	42	55	94	18
Na poptávku	171E-19 EG	42	55	94	19
Na poptávku	171E-20 EG	42	55	94	20
Na poptávku	171E-21 EG	42	55	94	21
Na poptávku	171E-22 EG	42	55	94	22
Na poptávku	171E-23 EG	42	55	94	23
Na poptávku	171E-24 EG	42	55	94	24
Na poptávku	171E-25 EG	42	55	94	25
Na poptávku	171E-26 EG	42	55	94	26
Na poptávku	171E-27 EG	42	55	94	27
Na poptávku	171E-28 EG	42	55	94	28
Na poptávku	171E-29 EG	42	55	94	29
Na poptávku	171E-30 EG	42	55	94	30
Na poptávku	171E-31 EG	42	55	94	31
Na poptávku	171E-32 EG	42	55	94	32
Na poptávku	171E-33 EG	42	55	94	33
Na poptávku	171E-34 EG	42	55	94	34
Na poptávku	171E-35 EG	42	55	94	35
Na poptávku	171E-36 EG	42	55	94	36
na poptávku	171E-37 EG	42	55	94	37

**Profil kleštiny  
obvodově drážkovaný  
EO**



Kód výrobku	Typ	D <sub>1</sub>	D <sub>2</sub>	L	d
800006793	171E- 9 EO	42	55	94	9
800006794	171E-10 EO	42	55	94	10
800006795	171E-11 EO	42	55	94	11
800006796	171E-12 EO	42	55	94	12
800006797	171E-13 EO	42	55	94	13
800006798	171E-14 EO	42	55	94	14
800006799	171E-15 EO	42	55	94	15
800006800	171E-16 EO	42	55	94	16
800006801	171E-17 EO	42	55	94	17
800006802	171E-18 EO	42	55	94	18
800006803	171E-19 EO	42	55	94	19
800006804	171E-20 EO	42	55	94	20
800006805	171E-21 EO	42	55	94	21
800006806	171E-22 EO	42	55	94	22
800006807	171E-23 EO	42	55	94	23
800006808	171E-24 EO	42	55	94	24
800006809	171E-25 EO	42	55	94	25
800006810	171E-26 EO	42	55	94	26
800006811	171E-27 EO	42	55	94	27
800006812	171E-28 EO	42	55	94	28
800006813	171E-29 EO	42	55	94	29
800006814	171E-30 EO	42	55	94	30
800006815	171E-31 EO	42	55	94	31
800006816	171E-32 EO	42	55	94	32
800006817	171E-33 EO	42	55	94	33
800006818	171E-34 EO	42	55	94	34
800006819	171E-35 EO	42	55	94	35
800006820	171E-36 EO	42	55	94	36
na poptávku	171E-37 EO	42	55	94	37

**171E**

■ Kleštiny pro upínání materiálu dle DIN 6343

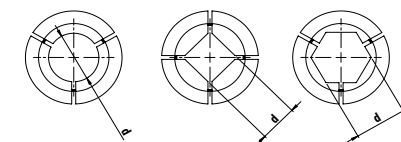
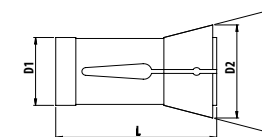

■ Jiné rozměry kleštin (po 0,5mm nebo jiné) nebo čtyřhran šestihranné profily kleštin jsou na poptávku!

# 173E

■ Kleštiny pro upínání materiálu dle DIN 6343

**Profil kleštiny  
hladký  
EG**



**Profil kleštiny  
obvodově drážkovaný  
EO**

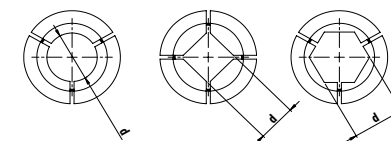
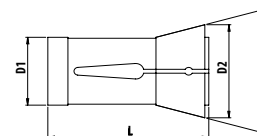

**Profil kleštiny  
šestihranný  
S**



**Profil kleštiny  
čtyřhranný  
K**



Kód výrobku	Typ	D <sub>1</sub>	D <sub>2</sub>	L	d
800006017	173E-4-EG	48	60	94	4
800006074	173E-5-EG	48	60	94	5
800006075	173E-6-EG	48	60	94	6
800006076	173E-7-EG	48	60	94	7
800006007	173E-8-EG	48	60	94	8
800006008	173E-9-EG	48	60	94	9
Na poptávku	173E-10-EG	48	60	94	10
Na poptávku	173E-11-EG	48	60	94	11
800006042	173E-12-EG	48	60	94	12
Na poptávku	173E-13-EG	48	60	94	13
Na poptávku	173E-14-EG	48	60	94	14
Na poptávku	173E-15-EG	48	60	94	15
Na poptávku	173E-16-EG	48	60	94	16
Na poptávku	173E-17-EG	48	60	94	17
Na poptávku	173E-18-EG	48	60	94	18
Na poptávku	173E-19-EG	48	60	94	19
Na poptávku	173E-20-EG	48	60	94	20
Na poptávku	173E-21-EG	48	60	94	21
Na poptávku	173E-22-EG	48	60	94	22
Na poptávku	173E-23-EG	48	60	94	23
Na poptávku	173E-24-EG	48	60	94	24
Na poptávku	173E-25-EG	48	60	94	25
Na poptávku	173E-26-EG	48	60	94	26
Na poptávku	173E-27-EG	48	60	94	27
Na poptávku	173E-28-EG	48	60	94	28
Na poptávku	173E-29-EG	48	60	94	29
Na poptávku	173E-30-EG	48	60	94	30
Na poptávku	173E-31-EG	48	60	94	31
Na poptávku	173E-32-EG	48	60	94	32
Na poptávku	173E-33-EG	48	60	94	33
Na poptávku	173E-34-EG	48	60	94	34
Na poptávku	173E-35-EG	48	60	94	35
Na poptávku	173E-36-EG	48	60	94	36
Na poptávku	173E-37-EG	48	60	94	37
Na poptávku	173E-38-EG	48	60	94	38
Na poptávku	173E-39-EG	48	60	94	39
Na poptávku	173E-40-EG	48	60	94	40
Na poptávku	173E-41-EG	48	60	94	41
Na poptávku	173E-42-EG	48	60	94	42

Kód výrobku	Typ	D <sub>1</sub>	D <sub>2</sub>	L	d
800006077	173E-9-EO	48	60	94	9
800006045	173E-10-EO	48	60	94	10
800006078	173E-11-EO	48	60	94	11
800006009	173E-12-EO	48	60	94	12
800006079	173E-13-EO	48	60	94	13
800006025	173E-14-EO	48	60	94	14
800006046	173E-15-EO	48	60	94	15
800006080	173E-16-EO	48	60	94	16
800006081	173E-17-EO	48	60	94	17
800006034	173E-18-EO	48	60	94	18
800006082	173E-19-EO	48	60	94	19
800006026	173E-20-EO	48	60	94	20
800006083	173E-21-EO	48	60	94	21
800006084	173E-22-EO	48	60	94	22
800006085	173E-23-EO	48	60	94	23
800006086	173E-24-EO	48	60	94	24
800006027	173E-25-EO	48	60	94	25
800006087	173E-26-EO	48	60	94	26
800006088	173E-27-EO	48	60	94	27
800006089	173E-28-EO	48	60	94	28
800006090	173E-29-EO	48	60	94	29
800006091	173E-30-EO	48	60	94	30
800006092	173E-31-EO	48	60	94	31
800006035	173E-32-EO	48	60	94	32
800006093	173E-33-EO	48	60	94	33
800006094	173E-34-EO	48	60	94	34
800006095	173E-35-EO	48	60	94	35
800006096	173E-36-EO	48	60	94	36
800006097	173E-37-EO	48	60	94	37
800006098	173E-38-EO	48	60	94	38
800006099	173E-39-EO	48	60	94	39
800006100	173E-40-EO	48	60	94	40
800006020	173E-41-EO	48	60	94	41
800006041	173E-42-EO	48	60	94	42

Kód výrobku	Typ	D <sub>1</sub>	D <sub>2</sub>	L	d
800006101	173E-4-S	48	60	94	4
800006102	173E-5-S	48	60	94	5
800006103	173E-6-S	48	60	94	6
800006104	173E-7-S	48	60	94	7
800006105	173E-8-S	48	60	94	8
800006106	173E-9-S	48	60	94	9
800006107	173E-10-S	48	60	94	10
800006108	173E-11-S	48	60	94	11
800006109	173E-12-S	48	60	94	12
800006110	173E-13-S	48	60	94	13
800006111	173E-14-S	48	60	94	14
800006112	173E-15-S	48	60	94	15
800006113	173E-16-S	48	60	94	16
800006114	173E-17-S	48	60	94	17
800006115	173E-19-S	48	60	94	19
800006116	173E-22-S	48	60	94	22
800006117	173E-24-S	48	60	94	24
800006118	173E-27-S	48	60	94	27
800006047	173E-30-S	48	60	94	30
800006119	173E-32-S	48	60	94	32
800006021	173E-36-S	48	60	94	36

Kód výrobku	Typ	D <sub>1</sub>	D <sub>2</sub>	L	d
800006120	173E-4-K	48	60	94	4
800006121	173E-5-K	48	60	94	5
800006048	173E-6-K	48	60	94	6
800006122	173E-7-K	48	60	94	7
800006123	173E-8-K	48	60	94	8
800006124	173E-9-K	48	60	94	9
800006125	173E-10-K	48	60	94	10
800006126	173E-11-K	48	60	94	11
800006272	173E-12-K	48	60	94	12
800006127	173E-13-K	48	60	94	13
800006128	173E-14-K	48	60	94	14
800006129	173E-16-K	48	60	94	16
800006130	173E-18-K	48	60	94	18
800006131	173E-20-K	48	60	94	20
800006132	173E-22-K	48	60	94	22
800006133	173E-24-K	48	60	94	24
800006134	173E-25-K	48	60	94	25
800006135	173E-28-K	48	60	94	28
800006136	173E-30-K	48	60	94	30

■ Jiné rozměry kleštin (po 0,5mm nebo jiné ) a speciální profily kleštin jsou na poptávku!

1  
2  
3  
4  
5  
6  
7



**Profil kleštiny  
hladký  
EG**



Kód výrobku	Typ	D <sub>1</sub>	D <sub>2</sub>	L	d
800006138	185E-4-EG	66	84	110	4
800006139	185E-5-EG	66	84	110	5
800006013	185E-6-EG	66	84	110	6
800006140	185E-7-EG	66	84	110	7
800006037	185E-8-EG	66	84	110	8
800006141	185E-9-EG	66	84	110	9
Na požávku	185E-10-EG	66	84	110	10
Na požávku	185E-11-EG	66	84	110	11
Na požávku	185E-12-EG	66	84	110	12
Na požávku	185E-13-EG	66	84	110	13
Na požávku	185E-14-EG	66	84	110	14
Na požávku	185E-15-EG	66	84	110	15
Na požávku	185E-16-EG	66	84	110	16
Na požávku	185E-17-EG	66	84	110	17
Na požávku	185E-18-EG	66	84	110	18
Na požávku	185E-19-EG	66	84	110	19
Na požávku	185E-20-EG	66	84	110	20
Na požávku	185E-21-EG	66	84	110	21
Na požávku	185E-22-EG	66	84	110	22
Na požávku	185E-23-EG	66	84	110	23
Na požávku	185E-24-EG	66	84	110	24
Na požávku	185E-25-EG	66	84	110	25
Na požávku	185E-26-EG	66	84	110	26
Na požávku	185E-27-EG	66	84	110	27
Na požávku	185E-28-EG	66	84	110	28
Na požávku	185E-29-EG	66	84	110	29
Na požávku	185E-30-EG	66	84	110	30
Na požávku	185E-31-EG	66	84	110	31
Na požávku	185E-32-EG	66	84	110	32
Na požávku	185E-33-EG	66	84	110	33
Na požávku	185E-34-EG	66	84	110	34
Na požávku	185E-35-EG	66	84	110	35
Na požávku	185E-36-EG	66	84	110	36
Na požávku	185E-37-EG	66	84	110	37
Na požávku	185E-38-EG	66	84	110	38
Na požávku	185E-39-EG	66	84	110	39
Na požávku	185E-40-EG	66	84	110	40
Na požávku	185E-41-EG	66	84	110	41
Na požávku	185E-42-EG	66	84	110	42
Na požávku	185E-43-EG	66	84	110	43
Na požávku	185E-44-EG	66	84	110	44
Na požávku	185E-45-EG	66	84	110	45
Na požávku	185E-46-EG	66	84	110	46
Na požávku	185E-47-EG	66	84	110	47
Na požávku	185E-48-EG	66	84	110	48
Na požávku	185E-49-EG	66	84	110	49
Na požávku	185E-50-EG	66	84	110	50
Na požávku	185E-51-EG	66	84	110	51
Na požávku	185E-52-EG	66	84	110	52
Na požávku	185E-53-EG	66	84	110	53
Na požávku	185E-54-EG	66	84	110	54
Na požávku	185E-55-EG	66	84	110	55
Na požávku	185E-56-EG	66	84	110	56
Na požávku	185E-57-EG	66	84	110	57
Na požávku	185E-58-EG	66	84	110	58
Na požávku	185E-59-EG	66	84	110	59
Na požávku	185E-60-EG	66	84	110	60

**Profil kleštiny  
obvodově drážkovaný  
EO**



Kód výrobku	Typ	D <sub>1</sub>	D <sub>2</sub>	L	d
800006142	185E-9-EO	66	84	110	9
800006029	185E-10-EO	66	84	110	10
800006143	185E-11-EO	66	84	110	11
800006014	185E-12-EO	66	84	110	12
800006144	185E-13-EO	66	84	110	13
800006015	185E-14-EO	66	84	110	14
800006016	185E-15-EO	66	84	110	15
800006145	185E-16-EO	66	84	110	16
800006146	185E-17-EO	66	84	110	17
800006147	185E-18-EO	66	84	110	18
800006148	185E-19-EO	66	84	110	19
800006149	185E-20-EO	66	84	110	20
800006030	185E-21-EO	66	84	110	21
800006150	185E-22-EO	66	84	110	22
800006151	185E-23-EO	66	84	110	23
800006152	185E-24-EO	66	84	110	24
800006153	185E-25-EO	66	84	110	25
800006154	185E-26-EO	66	84	110	26
800006155	185E-27-EO	66	84	110	27
800006049	185E-28-EO	66	84	110	28
800006156	185E-29-EO	66	84	110	29
800006157	185E-30-EO	66	84	110	30
800006158	185E-31-EO	66	84	110	31
800006031	185E-32-EO	66	84	110	32
800006159	185E-33-EO	66	84	110	33
800006160	185E-34-EO	66	84	110	34
800006161	185E-35-EO	66	84	110	35
800006032	185E-36-EO	66	84	110	36
800006162	185E-37-EO	66	84	110	37
800006163	185E-38-EO	66	84	110	38
800006164	185E-39-EO	66	84	110	39
800006036	185E-40-EO	66	84	110	40
800006165	185E-41-EO	66	84	110	41
800006050	185E-42-EO	66	84	110	42
800006166	185E-43-EO	66	84	110	43
800006167	185E-44-EO	66	84	110	44
800006168	185E-45-EO	66	84	110	45
800006169	185E-46-EO	66	84	110	46
800006170	185E-47-EO	66	84	110	47
800006171	185E-48-EO	66	84	110	48
800006172	185E-49-EO	66	84	110	49
800006173	185E-50-EO	66	84	110	50
800006174	185E-51-EO	66	84	110	51
800006175	185E-52-EO	66	84	110	52
800006176	185E-53-EO	66	84	110	53
800006177	185E-54-EO	66	84	110	54
800006178	185E-55-EO	66	84	110	55
800006179	185E-56-EO	66	84	110	56
800006180	185E-57-EO	66	84	110	57
800006181	185E-58-EO	66	84	110	58
800006182	185E-59-EO	66	84	110	59
800006183	185E-60-EO	66	84	110	60

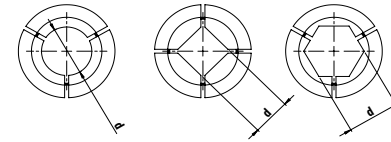

**Profil kleštiny  
šestihřanný  
S**



Kód výrobku	Typ	D <sub>1</sub>	D <sub>2</sub>	L	d
800006184	185E-4-S	66	84	110	4
800006185	185E-5-S	66	84	110	5
800006186	185E-6-S	66	84	110	6
800006187	185E-7-S	66	84	110	7
800006188	185E-8-S	66	84	110	8
800006189	185E-9-S	66	84	110	9
800006190	185E-10-S	66	84	110	10
800006191	185E-11-S	66	84	110	11
800006192	185E-12-S	66	84	110	12
800006193	185E-13-S	66	84	110	13
800006194	185E-14-S	66	84	110	14
800006195	185E-15-S	66	84	110	15
800006196	185E-16-S	66	84	110	16
800006197	185E-17-S	66	84	110	17
800006198	185E-19-S	66	84	110	19
800006199	185E-22-S	66	84	110	22
800006200	185E-24-S	66	84	110	24
800006012	185E-27-S	66	84	110	27
800006201	185E-30-S	66	84	110	30
800006202	185E-32-S	66	84	110	32
800006203	185E-36-S	66	84	110	36
800006204	185E-38-S	66	84	110	38
800006205	185E-41-S	66	84	110	41
800006206	185E-46-S	66	84	110	46
800006207	185E-50-S	66	84	110	50

**185E**

■ Kleštiny pro upínání materiálu dle DIN 6343

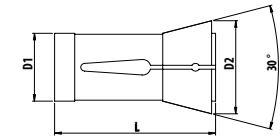

**Profil kleštiny  
čtyřhranný  
K**



Kód výrobku	Typ	D <sub>1</sub>	D <sub>2</sub>	L	d
800006208	185E-4-K	66	84	110	4
800006209	185E-5-K	66	84	110	5
800006210	185E-6-K	66	84	110	6
800006211	185E-7-K	66	84	110	7
800006212	185E-8-K	66	84	110	8
800006213	185E-9-K	66	84	110	9
800006214	185E-10-K	66	84	110	10
800006215	185E-11-K	66	84	110	11
800006216	185E-12-K	66	84	110	12
800006217	185E-13-K	66	84	110	13
800006218	185E-14-K	66	84	110	14
800006219	185E-16-K	66	84	110	16
800006220	185E-18-K	66	84	110	18
800006221	185E-20-K	66	84	110	20
800006222	185E-22-K	66	84	110	22
800006223	185E-24-K	66	84	110	24
800006224	185E-25-K	66	84	110	25
800006225	185E-28-K	66	84	110	28
800006226	185E-30-K	66	84	110	30
800006227	185E-32-K	66	84	110	32
800006228	185E-36-K	66	84	110	36
800006229	185E-40-K	66	84	110	40

■ Jiné rozměry kleštin (po 0,5mm nebo jiné) a speciální profily kleštin jsou na požávku!

4414

■ Nožová hlava pro rychlovýměnné držáky



- T.1
- T.1.X
- T.2
- T.2.T
- T.3
- T.3.HX

- T.00.M
- T.00.B
- T.0

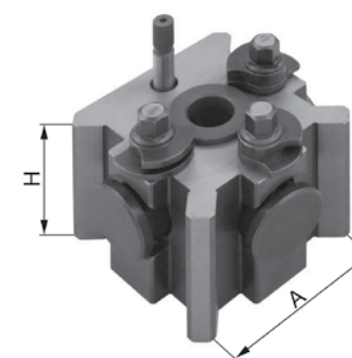
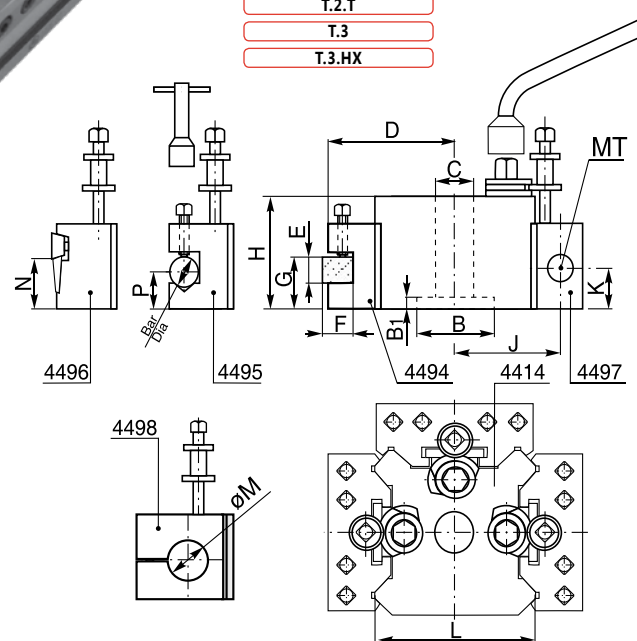
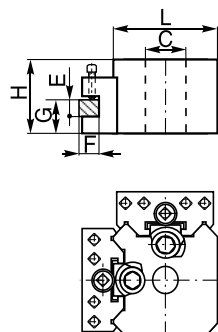

Velikost	H	B	B <sub>1</sub>	C	D	E	F	G max.	G min.	Bar Dia	P max.	P min.	MK	J	K max.	K min.	L	N	M	Kód výrobku	Typ	A x H	Rozsah upínání
T.00.M	37,0	—	—	11,2	50,0	12	11,0	27,0	17,0	11,0	22,5	12,5	—	—	—	—	58,0	16,0	—	80000651	T.00.M	48 x 37	Od 89 mm
T.00.B	42,0	—	—	16,0	50,0	12	11,0	32,0	17,0	11,0	27,5	12,5	—	—	—	—	58,0	16,0	—	80000652	T.00.B	48 x 42	Od 89 mm
T.0	51,0	22,22	12,5	19,0	62,0	16	13,0	36,5	20,5	16,0	32,0	16,0	1	52,5	28,5	16,0	73,0	27,0	19,0	80000653	T.0	62 x 51	Od 114 mm
T.1	63,5	31,75	8,5	19,0	62,0	20	13,0	46,0	30,0	16,0	44,5	25,5	1	52,5	41,0	22,0	73,0	27,0	19,0	80000654	T.1	62 x 63	114 mm do 127 mm
T.1.X	73,0	31,75	8,5	19,0	62,0	20	13,0	57,0	35,0	16,0	54,0	32,0	1&2	52,5	51,0	28,5	73,0	27,0	19,0	80000655	T.1.X	62 x 73	114 mm do 127 mm
T.2	71,5	44,45	9,5	25,5	74,5	20	19,0	52,5	36,5	19,0	46,0	24,0	2	65,0	47,5	27,0	97,0	33,5	25,4	80000656	T.2	82 x 71	127 mm do 203 mm
T.2.T	76,0	44,45	9,5	25,5	84,0	25	25,5	58,5	39,5	19,0	50,0	24,0	2	70,0	51,0	27,0	106,0	33,5	25,4	80000657	T.2.T	82 x 76	127 mm do 203 mm
T.3	95,5	50,80	11,5	25,5	101,5	32	25,5	74,5	51,0	25,5	51,0	28,5	3	85,5	58,2	36,5	125,5	39,5	38,0	80000658	T.3	100 x 92	203 mm do 292 mm
T.3.HX	108,0	50,80	11,5	25,5	101,5	32	25,5	84,0	62,0	25,5	65,0	41,0	3	85,5	58,2	36,5	125,5	39,5	38,0	80000659	T.3.HX	100 x 108	203 mm do 292 mm

**4494**

■ Standardní držák

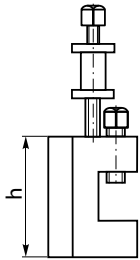

Kód výrobku	Velikost	Do	b x h
80000660	48	T.00M, T.00B	58 x 27
80000663	62N	T.0	73 x 35
80000662	62	T.1, T.1X	73 x 44
80000665	82N	T.2	98,5 x 50
80000664	82	T.2T	98,5 x 57
80000666	100	T.3, T.3HX	124 x 70

b - délka

**4497**

■ Držák s kuzelem Morse

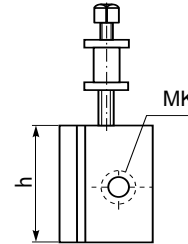

Kód výrobku	Velikost	Do	MK / MT
80000680	62/1N	T.0	1
80000679	62/1	T.1, T.1X	1
80000681	62/2	T.1, T.1X	2
80000682	82/2	T.2, T.2T	2
80000683	100/3	T.3, T.3HX	3

**4495**

■ Držák typu V

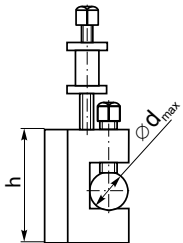

Kód výrobku	Velikost	Do	Ød <sub>max</sub>	b x h
80000667	48	T.00M, T.00B	11,0	58 x 27
80000670	62N	T.0	16,0	73 x 35
80000669	62	T.1, T.1X	16,0	73 x 44
80000672	82N	T.2	19,0	98,5 x 50
80000671	82	T.2T	19,0	98,5 x 57
80000673	100	T.3, 3HX	25,5	124 x 70

b - délka

**4498**

■ Držák s válcovým otvorem

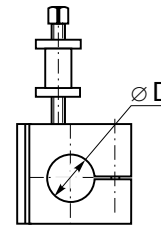

Kód výrobku	Velikost	Do	ØD
80000684	62	T.0, T.1, T.1X	19
80000685	82	T.2, T.2T	25,4
80000687	100	T.3, T.3HX	38

**4496**

■ Standardní držák

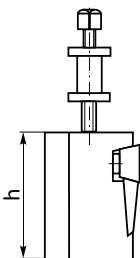

Kód výrobku	Velikost	Do	b x h
80000674	48	T.00M, T.00B	58 x 32
80000676	62	T.0, T.1, T.1X	73 x 47,5
80000677	82	T.2, T.2T	98,5 x 57
80000678	100	T.3, T.3HX	124 x 70

b - délka

**4499**

■ Držák s válcovým otvorem

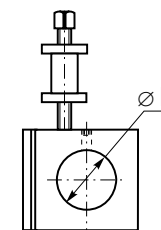

Kód výrobku	Velikost	Do	ØD
80000688	62	T.0, T.1, T.1X	25
80000689	82	T.2, T.2T	32
80000690	100	T.3, T.3HX	40

## 7272

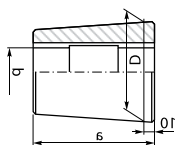

■ Kuželová pouzdra pro frézařské trny

Kód výrobku	d	D	a
800001258	16	47	80
800001259	22	47	80
800001260	22	70	100
800001261	27	47	80
800001262	27	70	100
800001263	32	47	80
800001264	32	70	100
800001265	40	70	100
800001266	40	86	100
800001267	50	70	100
800001268	50	86	100
800001269	60	86	100

## 7275

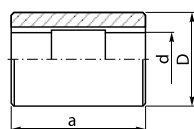

■ Válcová pouzdra pro frézařské trny

Kód výrobku	d	D	a
800001270	16	42	60
800001271	16	48	70
800001273	16	56	80
800001274	22	42	60
800001275	22	48	70
800001278	22	56	80
800001279	22	70	100
800001281	27	42	60
800001283	27	48	70
800001285	27	56	80
800001286	27	70	100
800001288	27	85	120
800001290	32	48	70
800001292	32	56	80
800001293	32	70	100
800001295	32	85	120
800001297	40	56	80
800001298	40	70	100
800001300	40	85	120
800001303	50	70	100
800001305	50	85	120
800001301	50	110	140
800001306	60	110	140
800001308	80	110	140
800001311	100	140	160

## 7285

■ Vymezovací kroužky pro frézařské trny

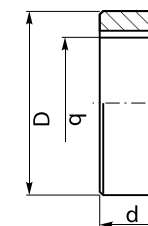
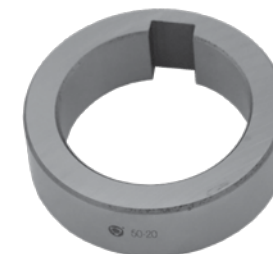

Kód výrobku	d	D	b
800001312	16	26	1
800001313	16	27	2
800001314	16	27	3
800001315	16	27	6
800001316	16	27	10
800001317	16	27	20
800001318	16	27	30
800001320	22	33	1
800001321	22	34	2
800001322	22	34	3
800001323	22	34	6
800001324	22	34	10
800001325	22	34	20
800001326	22	34	30
800001327	22	34	60
800001328	27	40	1
800001329	27	41	2
800001330	27	41	3
800001331	27	41	6
800001332	27	41	10
800001333	27	41	20
800001334	27	41	30
800001335	27	41	60
800001336	27	41	100
800001337	32	46	1
800001338	32	47	2
800001339	32	47	3
800001340	32	47	6
800001341	32	47	10
800001342	32	47	20
800001343	32	47	30
800001344	32	47	60
800001345	32	47	100
800001346	40	54	1
800001347	40	55	2
800001348	40	55	3
800001349	40	55	6
800001350	40	55	10
800001351	40	55	20
800001352	40	55	30
800001353	40	55	60
800001354	40	55	100

Kód výrobku	d	D	b
800001355	50	68	1
800001356	50	69	2
800001357	50	69	3
800001358	50	69	6
800001359	50	69	10
800001360	50	69	20
800001361	50	69	30
800001362	50	69	60
800001363	50	69	100
800001364	60	83	1
800001365	60	84	2
800001366	60	84	3
800001367	60	84	6
800001368	60	84	10
800001369	60	84	20
800001370	60	84	30
800001372	60	84	60
800001373	60	84	100

1

2

3

4

5

6

7

**KL 9833**

- Klíč pro matice ER standard typ 9833



Typ	Kód výrobku	Pro	L
KL 9833-ER16	800003764	ER16	150
K L9833-ER20	800003328	ER20	170
KL 9833-ER25	800003329	ER25	190
KL 9833-ER32	800003341	ER32	240
KL 9833-ER40	800003765	ER40	270
KL 9833-ER50	800003766	ER50	340

**9833**

- Matice pro klešťinové upínače ER
- Typ 9833-ES - vyvážené matice
- Typ 9833 - standardní typ

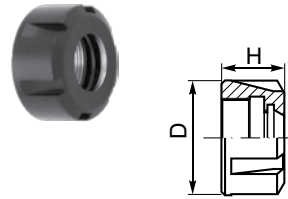

Typ	Kód výrobku	Typ	Kód výrobku	Pro	D	H
9833-16ES	800005308	9833-16	800002977	ER16	32	17,5
9833-20ES	800005309	9833-20	800002978	ER20	35	19,0
9833-25ES	800005310	9833-25	800002979	ER25	42	20,0
9833-32ES	800005311	9833-32	800002980	ER32	50	22,5
9833-40ES	800005312	9833-40	800002981	ER40	63	25,5

**1911**

- Optické dotykové židlo

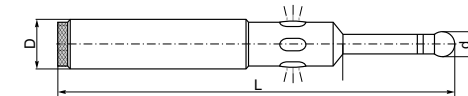

- Rychlé stanovení polohy předmětu
- Úspora času při stanovení polohy na frézkách, vrtačkách a jiných obráběcích strojích
- Přesnost 0.005 mm
- 2 baterie 1.5 V (nejsou součástí dodávky)

Kód výrobku	Typ	D	d	L
800003192	1911-LS	20	10	157

**KL 9833-D**

- Klíč pro matice šestirahnné typu 9833-D



Typ	Kód výrobku	Pro	L
KL9833-11D	800003767	ER11	125
KL9833-16D	800003183	ER16	170
KL9833-20D	800003768	ER20	140

**9833-D**

- Matice šestirahnné pro klešťinové upínače ER

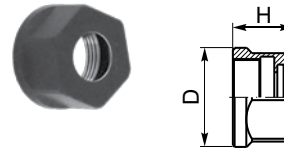

Typ	Kód výrobku	Pro	D	H
9833-11 D	800003760	ER11	19	11,0
9833-16 D	800002982	ER16	28	17,5
9833-20 D	800003510	ER20	34	20,0

**KL 9833-S**

- Klíč pro matice ER mini typu 9833-S

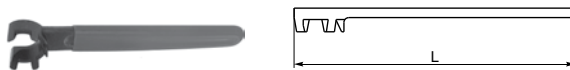

Typ	Kód výrobku	Pro	L
KL 9833-11S	800003769	ER11	95
KL 9833-16S	800003184	ER16	119
KL 9833-20S	800003770	ER20	131
KL 9833-25S	800003771	ER25	143

**9833-S**

- Matice ER mini pro klešťinové upínače ER

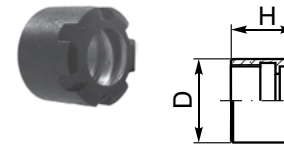

Typ	Kód výrobku	Pro	D	H
9833-11 S	800003757	ER11	16	12
9833-16 S	800002983	ER16	22	18
9833-20 S	800003758	ER20	28	19
9833-25 S	800003759	ER25	35	20

## KL 9876

■ Klíče pro upínací šrouby

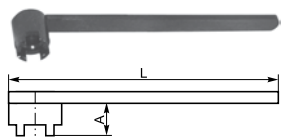

Typ	Kód výrobku	Velikost	L	A
KL 9876-13	800003756	13	160	16
KL 9876-16	800002989	16	180	20
KL 9876-22	800002990	22	200	23
KL 9876-27	800002991	27	225	32
KL 9876-32	800002992	32	250	36
KL 9876-40	800002993	40	280	40
KL 9876-50	800002994	50	315	45
KL 9876-60	800002995	60	355	50

## UPÍNACÍ ŠROUB

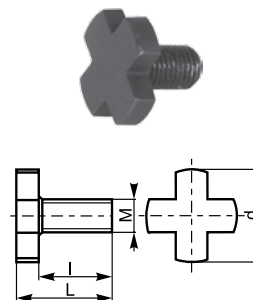

Typ	Kód výrobku	M	l	d	L
U-0620/0	800003072	M8	16	20	22
U-0621/0	800003073	M10	18	28	25
U-0622/0	800003074	M12	22	35	30
U-0623/0	800003075	M16	26	42	35
U-0624/0	800003076	M20	30	52	40
U-0625/0	800003077	M24	36	63	48

## UNAŠEČ B

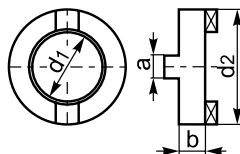

Typ	Kód výrobku	d <sub>1</sub>	d <sub>2</sub>	a	b
U-1364/0	800003084	16	32	8	10
U-1365/0	800003085	22	40	10	12
U-1366/0	800003086	27	48	12	12
U-1367/0	800003087	32	58	14	14
U-1368/0	800003088	40	70	16	14
U-1369/0	800003089	50	90	18	16

## KÁMEN A

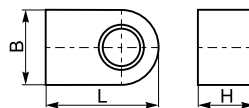

Typ	Kód výrobku	B	H	L
S-2111/0	800003057	12	9	24
S-2114/0	800003058	14	12	28
S-2117/0	800003059	8	7	17
S-2121/0	800003060	10	8	20,6
S-2124/0	800003061	16	12	32
U-5974/0	800003110	18	16	33
U-6064/0	800003114	15,9	16	20
U-6065/0	800003115	25,4	25	34,5
U-6066/0	800003116	25,4	25	29,5
W-1945/0	800005683	8	8	16,8
W-1946/0	800005684	10	10	20,4
W-1947/0	800005685	12	12	24,1
W-1948/0	800005686	14	14	27,8
W-1949/0	800005687	16	16	31,8
W-3649/0	800006778	14	12	22,8
W-3651/0	800006779	16	12	23,8

## ČEP C

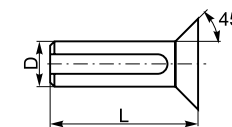

Typ	Kód výrobku	L	D
U-6510/1	800005699	52	16
U-6511/1	800005700	82	16
U-6512/1	800005701	52	22
U-6513/1	800005702	82	22
U-6514/1	800005703	52	27
U-6515/1	800005704	82	27
U-6516/1	800005705	52	32
U-6517/1	800005706	82	32
U-6518/1	800005707	52	40
U-6519/1	800005708	82	40

## PERO A

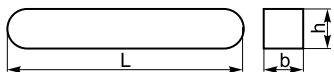

Typ	Kód výrobku	L	b	h
U-1355/0	800005745	20	4	5
U-1356/0	800005746	25	6	5
U-1357/0	800005747	25	7	8
U-1358/0	800005748	32	8	7,6
U-1359/0	800005749	32	10	8,6
U-1360/0	800003083	36	12	9

## KÁMEN A

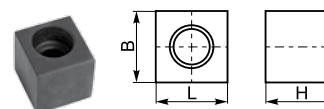

Typ	Kód výrobku	B	L	H
U-6227/0	800003119	15,9	16,5	16

## ČEP B

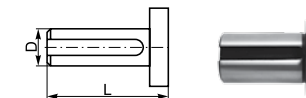

Typ	Kód výrobku	L	D
U-6510/0	800003121	52	16
U-6511/0	800003122	82	16
U-6512/0	800003123	52	22
U-6513/0	800003124	82	22
U-6514/0	800003125	52	27
U-6515/0	800003126	82	27
U-6516/0	800003127	52	32
U-6517/0	800003128	82	32
U-6518/0	800003129	52	40
U-6519/0	800003130	82	40

1

2

3

4

5

6

7

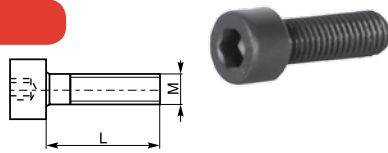
**ŠROUB A**

Typ	Kód výrobku	M	L
U-1414/0	800005895	M12	40
U-2042/0	800005905	M16	50
U-5335/0	800005892	M8	40
U-6520/0	800005891	M8	70
U-6523/0	800003131	M10	80
U-6524/0	800005894	M10	80
U-7682/0	800005890	M6	35
U-7683/0	800005893	M10	40

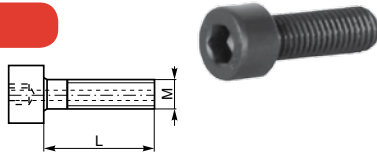
**ŠROUB B**

Typ	Kód výrobku	M	L
U-7790/0	800003161	M12	35
W-1091/0	800005624	M6	25
W-1092/0	800005625	M10	25
W-1093/0	800005626	M12	30
W-1094/0	800005627	M16	40
W-1095/0	800005628	M10	30
W-1096/0	800005629	M12	40
W-1097/0	800005630	M16	40
W-1098/0	800005631	M20	50

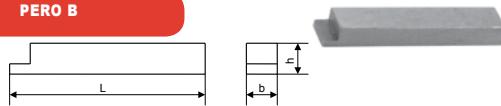
**PERO B**

Typ	Kód výrobku	L	b	h
U-6526/0	800003132	45	4	4
U-6527/0	800003133	75	4	4
U-6528/0	800003134	45	6	6
U-6529/0	800003135	75	6	6
U-6530/0	800003136	45	7	7
U-6531/0	800003137	75	7	7
U-6532/0	800003138	45	8	7
U-6533/0	800003139	75	8	7
U-6534/0	800003140	45	10	8
U-6535/0	800003141	75	10	8

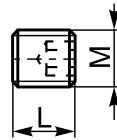
**ŠROUB A**

Typ	Kód výrobku	M	L
S-2628/0	800005822	M14x1	7
U-1997/0	800005823	M6	6
U-4131/0	800003091	M6	10
U-4132/0	800003092	M8	10
U-4133/0	800003093	M10	12
U-4134/0	800003094	M12	16
U-4135/0	800003095	M14	16
U-4136/0	800003096	M16	16
U-4137/0	800003097	M18x2	20
U-4138/0	800003098	M20x2	20
U-4139/0	800003099	M24x2	25
U-5870/0	800003107	M20x2	25
U-5887/0	800003108	M14	15
U-5888/0	800003109	M16	13
U-6755/0	800003144	M16x1	6,5
U-6756/0	800003145	M16	10
U-6757/0	800003146	M18x2	9,5
U-7381/0	800003157	M8	6
U-7382/0	800003158	M10	10

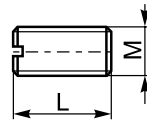
**ŠROUB B**

Typ	Kód výrobku	M	L
U-0293/0	800005796	M8	16
U-0757/0	800005797	M10	20
U-1599/0	800005798	M5	12
U-6317/0	800005799	M6	14
U-6318/0	800005800	M12	22
U-6793/0	800005801	M16	30
U-6794/0	800005802	M20	40

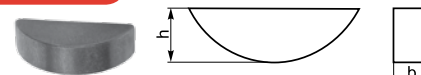
**PERO C**

Typ	Kód výrobku	b	h
S-0898/0	800003050	6	9
U-0097/0	800003068	3	3,7
U-0098/0	800003069	5	6,5
U-0106/0	800003071	12	19
U-0648/0	800003078	4	5
U-0649/0	800003079	8	11
U-0650/0	800003080	10	16

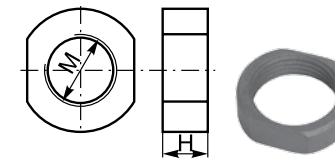
**MATICE B**

■ Stahovací matice pro typ 5310

Typ	Kód výrobku	M	L
S-0881/0	800003039	M12 x 1	6
S-0884/0	800003041	M16 x 1,5	7
S-0887/0	800003043	M20 x 1	8
S-0891/0	800003045	M22 x 1	9
S-0894/0	800003047	M27 x 2	12
S-0897/0	800003049	M30 x 2	12
S-0901/0	800003052	M36 x 3	14
S-0905/0	800003054	M45 x 3	16
S-0909/0	800003056	M52 x 3	16

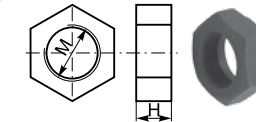
**MATICE A**

■ Stahovací matice

Typ	Kód výrobku	M	L
S-0772/0	800003031	12 x 1,5	10,5
S-0774/0	800003032	16 x 1,5	12
S-0776/0	800003033	22 x 1,5	15,5
S-0778/0	800003034	27 x 1,5	17,5
S-0780/0	800003035	36 x 1,5	21
S-0782/0	800003036	48 x 1,5	23
S-0784/0	800003037	68 x 1,5	25,5

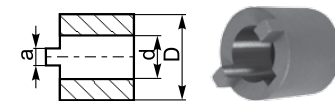
**UNAŠEČ A**

Typ	Kód výrobku	a	d	D
S-0880/0	800003038	4	10	18
S-0883/0	800003040	4	13	21
S-0886/0	800003042	5	16	27
S-0890/0	800003044	6	19	32
S-0893/0	800003046	7	22	39
S-0896/0	800003048	8	27	46
S-0900/0	800003051	10	32	56
S-0904/0	800003053	12	40	65
S-0908/0	800003055	14	50	80

## T-KLÍČ S VNITŘNÍM ČTYŘHRANEM



Typ	Kód výrobku	Čtyřhran K	Pro
KL 4414-62X51	800003029	K 8	T0, T1, T1X
KL 4414-82X71	800003030	K 10	T2, T2T
KL 4414-100X108	800003028	K 13,5	T3, T3HX

## KLÍČ S VNITŘ. ŠESTIHRANEM



Typ	Kód výrobku	Pro
KL 4414-48 HEX	800003103	T.00M, T.00B
KL 4414-62X51 HEX	800003149	T.0, T.1, T.1X
KL 4414-82X71 HEX	800003118	T.2, T.2T
KL 4414-100X108 HEX	800003150	T.3, T.3HX

## KOLÍK



Typ	Kód výrobku	Pro
U-7485/0	800003741	T.0
U-6863/0	800003742	T.1, T.1X
U-5760/0	800003743	T.2, T.2T
U-6871/0	800003744	T.3
U-7487/0	800003745	T.3HX

## POUZDRO



Typ	Kód výrobku	Pro
U-5514/1	800003737	T.00M
U-5514/0	800003738	T.00B
U-6876/0	800003151	T.0, T.1, T.1X
U-5762/0	800003106	T.2, T.2T
U-6880/0	800003154	T.3, T.3HX

## ŠROUB SE ČTYŘHRANNOU HLAVOU



Typ	Kód výrobku	Závít x rozměr	Hlava šroubu	Pro
U-5516/1	800005897	M5x20	inbus S 4	T.00M
U-5516/0	800005896	M5x20	inbus S 4	T.00B
U-6877/0	800003152	M8x25	čtyřhran K 8	T.0, T.1, T.1X
U-7386/0	800003159	M10x30	čtyřhran K 10	T.2, T.2T
U-6881/0	800003155	M12x40	čtyřhran K 13	T.3, T.3HX

## T-KLÍČ S VNĚJŠÍM ŠESTIHRANEM



Typ	Kód výrobku	Rozměr	Pro
KL 4414-48	800003168	inbus S 4	T00M, T00B

## EXCENTR



Typ	Kód výrobku	Pro
U-5507/1	800003739	T.00M
U-5507/0	800003101	T.00B
U-6860/0	800003148	T.0, T.1, T.1X
U-6175/0	800003117	T.2
U-5757/0	800003105	T.2T
U-6868/0	800003740	T.3, T.3HX

## PRUŽINA



Typ	Kód výrobku	Pro
U-5510/0	800003102	T.00M, T.00B
U-6862/0	800003753	T.0, T.1, T.1X
U-5759/0	800003754	T.2, T.2T
U-6870/0	800003755	T.3, T.3HX

## ŠROUB SE ČTYŘHRANNOU HLAVOU



Typ	Kód výrobku	Závít x rozměr	Hlava šroubu	Pro
U-5517/1	800005899	M5x16	inbus S 4	T.00M
U-5517/0	800005898	M5x16	inbus S 4	T.00B
U-6877/1	800003153	M8x25	čtyřhran K 8	T.2, T.2T
U-7386/1	800003160	M10x30	čtyřhran K 10	T.0, T.1, T.1X
U-6881/1	800003156	M12x40	čtyřhran K 13	T.3, T.3HX

## ČEP

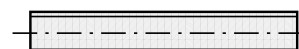

Kód výrobku	Typ	Pro
800005900	U-5515/1	T.00M
800005901	U-5515/0	T.00B
800005902	U-8578/0	T.0, T.1, T.1X
800005903	U-5754/0	T.2, T.2T
800005904	U-5997/0	T.3, T.3HX

## ČEP A



Typ	Kód výrobku	Pro
U-5505/1	800003746	T.00M
U-5505/0	800003747	T.00B
U-6859/0	800003147	T.0, T.1, T.1X
U-6174/0	800003748	T.2
U-5756/0	800003104	T.2T
U-6867/0	800003749	T.3, T.3HX

1  
2  
3  
4  
5  
6  
7